

The Effects of Social Isolation on the Behavior of Juvenile Domestic Cats

GARY W. GUYOT
THOMAS L. BENNETT
HENRY A. CROSS
*Department of Psychology
Colorado State University
Fort Collins, Colorado*

The effects of social isolation on the behavior of juvenile domestic cats were assessed by rearing 4 male and 4 female infant kittens in each of the following rearing conditions: (1) mother-littermate; (2) mother-only; (3) brooder-littermate; and (4) brooder-only. They were then tested twice a week individually and twice a week socially from 2 to 6½ months of age in a playroom, utilizing multiple categories of behavior. The mother-only-reared juveniles were hyperactive in both object play (when tested individually) and social play. The brooder-only-reared kittens displayed enhanced socially directed behavior and were generally hypergregarious, whereas the brooder-littermate-reared kittens displayed retarded social behavior. Observations indicated that littermate-deprived kittens did not learn social communication skills and that some prolonged separation effects existed for littermate-reared kittens. The results suggest that the determinants of social play are more complex than the determinants of object play.

Explanations of kitten (*Felis domesticus*) object and social play have generally centered on the idea that all kitten play serves as practice for prey-catching behavior (e.g., Egan, 1967; Leyhausen, 1973). This emphasis resulted from the similarity of the movements used in object and social play to the movements used in prey-catching. The movements are so similar that Leyhausen (1973) described them as being instinctive or innate. Support for the innate movement hypothesis comes from the fact that kittens, reared in isolation and made to wear opaque Plexiglas goggles until they were tested at 11 weeks of age, showed the same movements in prey-catching as normals (Thomas & Schaller, 1954). In addition, Kling, Kovach, and Tucker (1969) found that rearing kittens separately in incubators had no effect on the maturation of play or aggression. Play was maturationally complete at 35 days, and aggression was maturationally complete at 52 days, in both control and deprived animals.

Recently, West (1974) questioned whether object and social play had, indeed, similar functions. In a comprehensive normative study of kitten social play, she noted that whereas the play patterns seemed suited to the uniquenesses of a carnivore, social

Reprint requests should be sent to Dr. Gary W. Guyot, Department of Psychology, West Texas State University, Canyon, Texas 79016, U.S.A.

Received for publication 9 November 1977
Revised for publication 30 November 1978
Developmental Psychobiology, 13(3):317-329 (1980)
©1980 by John Wiley & Sons, Inc.

0012-1630/80/0013-0317\$01.00

play may also function to provide opportunities for the acquisition of social communication skills and to maintain friendly social relations among members of a litter. Kittens reared in total social isolation from infancy seem to be more aggressive and hostile toward other cats when they are tested for social behavior as adults (Kuo, 1960; Seitz, 1959). However, whether the isolation from the mother or littermates was responsible for the atypical social behavior has been questioned. Koepke and Pribram (1971) found that kittens which had access to an anesthetized, nonlactating female (dry suck group) did not differ in the onset or frequency of play from kittens that had access to a lactating female (milk suck group). However, the frequency of play by the dry suck group did peak earlier (9.5 weeks) than that of the milk suck group (16 weeks). (The investigators recorded as play any behavior that was playful regardless of whether it involved other kittens, the kitten itself, or some aspect of the environment.) They concluded that an active mother is not necessary for the development of normal social relations as long as kittens regularly have an opportunity for littermate interactions. Kuo (1960) also concluded that when isolated kittens have some opportunities to interact with other kittens, they are later friendly or indifferent (but not hostile) toward strange cats.

Individual behavior may also be affected by isolation. Seitz (1959) and Konrad and Bagshaw (1970) found that novelty has an unusually large impact on adults when they were totally isolated as kittens. The latter noted that early isolated cats initially react passively to a novel environment, although the frequency of their object play eventually equals that of normally reared cats.

These studies, taken as a whole, suggest that although the motor movements used in object and social play may be similar, these 2 types of play may have different functions and, thus, may be differentially affected by social isolation; for example, social aggression may be enhanced and initial object play may be retarded. However, the nature of the isolation may be important, depending on whether the kittens are isolated from their mother and/or their littermates and peers. Whether isolation affects object and social play differentially has yet to be determined. The previous studies have generally employed few categories of behavior and focused on object play alone, social play alone, or combined play. The purpose of the present investigation was to conduct a comprehensive study of the relative contribution of maternal and littermate interactions to social and individual behaviors in the juvenile kitten.

Method

Subjects

The subjects were 32 kittens (*Felis domesticus*). Males and females were randomly assigned to each of the following rearing conditions: (1) 2 kittens reared with their biological mother (mother-littermate); (2) 1 kitten reared with its biological mother (mother-only); (3) 2 kittens reared with a brooder (brooder-littermate); and (4) 1 kitten reared with a brooder (brooder-only). This assignment resulted in 4 male and 4 female kittens reared in each condition. The brooder provided warmth (32–38°C), contact (shag carpet), and milk (through a nipple). The subjects were reared in these rearing conditions from birth (if with a biological mother) or from 2 days (if with a

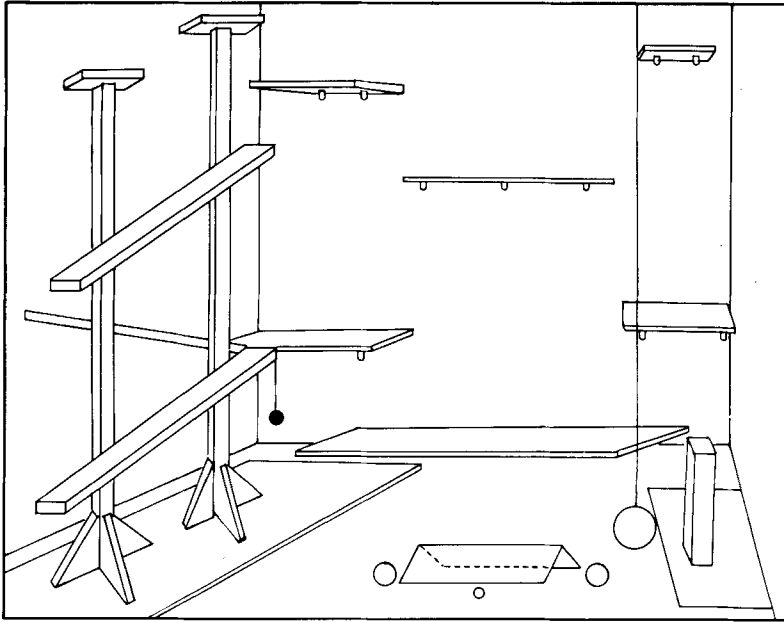

Fig. 1. Playroom where kittens were tested.

brooder) until 6 weeks of age. They were then weaned and housed in standard laboratory adult cat cages ($61 \times 45 \times 69$ cm) with their littermate, or alone, depending on the rearing condition. During infancy each kitten had been separated once a week (from 2 to 5 weeks of age) from its rearing condition and placed in an open field for 15 min in order to determine the distress produced by separation from the various rearing conditions (See Guyot, Cross, & Bennett, 1980).

Apparatus

The apparatus was a room specifically designed for observation of play behavior (see Fig. 1). The room ($1.88 \times 2.67 \times 2.72$ m) contained carpeted ramps, shelves, balls (both on the floor and hanging), a Plexiglas tunnel, a scratching post, and a pan of kitten litter. The shelves were numbered consecutively by height as were the ramps. A Plexiglas observation window (77.57×77.57 cm) protruded 15.24 cm into the playroom.

Scoring

A social and an individual behavioral checklist were constructed on the basis of Welker's (1961) categories of behavior. Specific motor behaviors were operationally defined and used initially to assess their feasibility in measuring adult cat behavior (Guyot, 1975) and modified slightly for the present study with kittens. The individual categories included biting, looking, touching, crawling under (Plexiglas tunnel or Shelf No. 1), jumping (except to a shelf or ramp), rolling, sniffing, striking, chasing, pouncing on, vigorous manipulation, shelf number (if on a shelf), ramp number (if on

a ramp), scratching carpet, grooming, resting, vocalization, random running, and piloerection. The social behaviors included biting, looking, sniffing, licking, touching, wrestling, slapping, chasing, approach, withdrawal, defensive, piloerection, lowering the ears, and sideways stance.¹

Each kitten was tested in the playroom twice a week individually and twice a week socially beginning at 8 weeks of age for 20 weeks. During individual testing, the subject was alone, and only the individual categories were used. During social testing a normal laboratory-reared stimulus animal was present and both the individual (labeled individual-social) and the social categories were used. Data were collected only on the experimental animal during social testing. A general description of the stimulus animal's behavior was recorded after each session.

Each testing session lasted 20 min. The 20-min session was divided into 80 successive 15-sec intervals. If a specific motor behavior occurred during a 15-sec interval, it was checked on a scoring sheet containing all of the categories and 80 sequential blocks for each category. The checks were then summed across blocks for each category to yield the frequency of each behavior for each testing session. The frequency scores of each category were then averaged in blocks of 2 testing sessions (for each week).

The 1st author collected 70% of these data. Other observers were trained extensively by him, and periodic checks were made to ensure proper use of the categories. When 2 observers tested together, all correlation coefficients were above .90.

Data Analysis

Each individual category was analyzed with a 2 (Mother/Brooder) \times 2 (Littermate/No Littermate) \times 2 (Male/Female) \times 2 (Individual/Individual-Social) \times 20 (Trial Blocks) split-plot analysis of variance with repeated measures (Kirk, 1968). Each social category was analyzed with a 2 (Mother/Brooder) \times 2 (Littermate/No Littermate) \times 2 (Male/Female) \times 20 (Trial Blocks) split-plot analysis of variance with repeated measures. Because preliminary analyses of the data with Barlett's statistic (Kirk, 1968) indicated a violation of the homogeneity of variance assumptions, a square root transformation ($\sqrt{X+1}$) was used. The LSD test (Kirk, 1968) was selected for comparison of treatment means. Because this test becomes more liberal as the number of treatments (k) increases (Snedecor & Cochran, 1967), $\alpha = .05$ when $k \leq 9$, and $\alpha = .01$ when $k \geq 10$ were selected as significance criteria. Finally, because the degrees of freedom associated with Trial Blocks were so large (19 and 456), the Geisser-Greenhouse conservative F test (Kirk, 1968) was imposed on all tests involving repeated measures. If the F value did not meet significance at 1 and 24 degrees of freedom, it is not reported. These procedures served to make the reported results more conservative in finding significant differences.

Stimulus Animals

The stimulus animals for social testing came from a number of normally reared litters in the laboratory. They were always the same age as the experimental kittens. Due to a gender imbalance in the litters, 2 male subjects in the mother-littermate-reared group were tested with females, and 2 females in the brooder-only-reared group

were tested with males. All other subjects were tested with same-sex stimulus animals during social testing.

Results

Individual/Individual-Social Testing

Because a large number of complex analyses yielded many significant effects, only a summary of the major results will be presented.² Also, categories that yielded similar significant results were combined on the tables and figures. Fewer differences than would be expected by chance alone were found between male and female subjects; thus no gender differences are reported.

The littermate-reared kittens displayed the most looking (orienting) during both individual and individual-social testing. These 2 groups also displayed the most object sniffing during social testing. However, the brooder-reared kittens displayed the most object sniffing during individual testing. (See Table 1.)

The categories of grooming, scratching the carpet, and resting showed identical effects and were combined under the heading of "self" behaviors. The mother-littermate-reared kittens displayed the most frequent self-behaviors, during both individual and individual-social testing, whereas the other 3 groups did not significantly differ among themselves.

One interesting result developed unexpectedly: the brooder-reared juvenile kittens did not "get off the ground"; that is, they seldom went higher than Shelf No. 1 which was only 20.32 cm from the floor. A 2nd analysis on the highest shelf and ramp attained by each kitten during each Trial Block showed identical group differences on shelves and ramps. However, brooder-littermate-reared kittens attained higher ramps than the brooder-only-reared kittens. All except one of the mother-reared kittens frequently went to the highest shelves and ramps.

Although the brooder-reared kittens seldom went up on the shelves and ramps, they did display significantly more random running during individual testing (running with no perceived goal object) than the mother-reared kittens. However, during social testing the littermate-deprived kittens randomly ran more than the mother-littermate-reared kittens.

The object play categories of striking, chasing, pouncing on, and vigorous manipulation showed similar effects and were combined under the heading of "Object Play." During individual testing the mother-only-reared kittens displayed significantly more object play than kittens reared in all of the other conditions. Often they would display these behaviors several times during a 15-sec interval, increasing the difficulty in following their behavior. In addition, the mother-only-reared kittens started out as being more hyperactive in their object play than the kittens reared in the other rearing conditions (Fig. 2). The brooder-reared kittens initially displayed little object play the 1st few weeks of testing. However, the brooder-littermate-reared kittens were playing as much as the mother-littermate-reared kittens after 6 weeks of testing, and the brooder-only-reared kittens were playing as much as the mother-littermate-reared kittens after 4 weeks of testing. This indicates that brooder-rearing may not have permanent effects on the frequency of object play, at least when the kittens are tested alone.

TABLE 1. Directional Comparisons of Treatment Means Following an Analysis of Variance on Each Category of Behavior Scored During Individual and Individual-Social Testing.^a

Categories	Individual greater than				Individual-Social greater than			
	1	2	3	4	1	2	3	4
Looking								
Sniffing	2,4		2,4		2,4		2,4	
Self-behavior	2,3,4		1,2	1,2	2,4		2,4	
Shelves and ramps	3,4	3,4			2,3,4	3,4		
Object play		1,3,4			3,4			
Object bite	3,4	1,3,4			4			
Random running						1		1
Vocalizations	2,4		1,2	1,2,3				
Pileorection		1,3	2,4	1,3		1,3		1,3

^aLeast Significant Difference Test, $p < .05$.

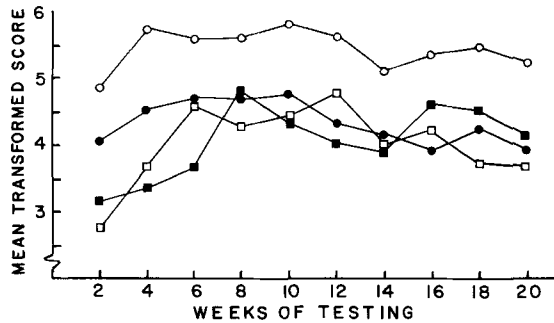

Fig. 2. Mean transformed frequency of object play when the kittens were tested individually averaged over the categories of slap, chase, pouncing on, and vigorous manipulation. ●, mother-littermate; ○, mother-only; ■, brooder-littermate; □, brooder-only.

When the kittens were tested socially a different picture emerged. Overall, the mother-littermate-reared kittens displayed significantly more object play when tested socially than the brooder-only-reared kittens. From the 4th through the 12th week of testing the mother-littermate-reared kittens were generally displaying more object play than all of the other kittens. The brooder-only-reared kittens, on the other hand, consistently displayed less object play when tested socially than all of the other kittens, from the 6th week on. No significant Trial Block effects existed for any of the object play categories. (Fig. 3.)

Differences were also found between individual and individual-social testing with object biting. Although no significant differences existed between groups in social testing, during individual testing the mother-only-reared kittens bit objects more than did all of the other kittens, and the mother-littermate-reared kittens bit objects more frequently than the brooder-reared kittens. No significant differences in vocalizations were found in social testing; in individual testing the littermate-reared kittens vocalized more frequently than the littermate-deprived kittens.

Piloerections during individual and social testing showed similar effects (Table 1): the littermate-deprived subjects displayed the most frequent piloerections during both individual and social testing.

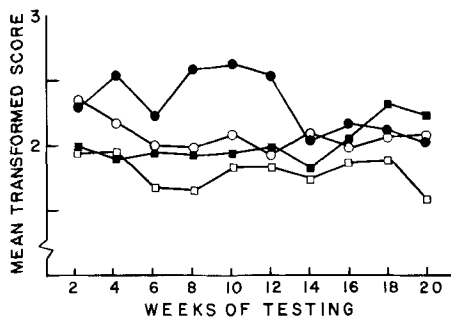

Fig. 3. Mean transformed frequency of object play when the kittens were tested socially averaged over the categories of slap, chase, pouncing on, and vigorous manipulation. For symbols, see Fig. 2.

No significant differences between groups were found with the categories of object touching, crawling under, jumping, or rolling. However, all of the kittens displayed significantly more frequent behavior in all of the individual (compared to individual-social) categories of behavior except for piloerection (generally a social response when tested socially), resting (where kittens would frequently rest between social play bouts), and crawling under. Although significantly more piloerections and resting occurred in social testing than individual testing, no significant differences existed between individual and social testing in crawling under. Crawling under the Plexiglas tunnel and under Shelf No. 1 occurred quite frequently both in individual and social play.

Social Behavior

One obvious effect is that the mother-only-reared kittens displayed significantly more slapping, chasing, and approaching than all of the other kittens. The littermate-deprived kittens overall displayed more significant biting, wrestling, approaching, lowering the ears, and sideways stance (as well as piloerection) than the littermate-reared kittens. The brooder-only reared kittens also displayed significantly more slapping than the brooder-littermate-reared kittens, and significantly more social touching than all of the other kittens. (See Table 2.)

The brooder-only-reared kittens as well as the mother-littermate-reared kittens licked the stimulus animal significantly more frequently than the mother-only- and the brooder-littermate-reared kittens. The mother-littermate-reared kittens also displayed significantly more withdrawal than the brooder-reared ones.

Because all 4 groups maintained the same order in the frequency of approaching, slapping, wrestling, and biting, these categories were combined and labeled "social play." Trial blocks were significant for each of these categories as well as the category of chasing. Chasing showed the same general effects as the other 4 social play

TABLE 2. Directional Comparisons of Treatment Means Following an Analysis of Variance on Each Social Category.^a

Group	Greater than			
	1	2	3	4
Categories	Mother-littermate	Mother-only	Brooder-littermate	Brooder-only
Bite		1,3		1,3
Lick	2,3			2,3
Touch				1,2,3
Wrestle	3	1,3		1,3
Slap	3	1,3,4		3
Chase		1,3,4		
Approach		1,3,4		1,3
Withdrawal	3,4	3,4		
Lower ears and sideways		1,3		1,3

^aLeast Significant Difference Test, $p < .05$.

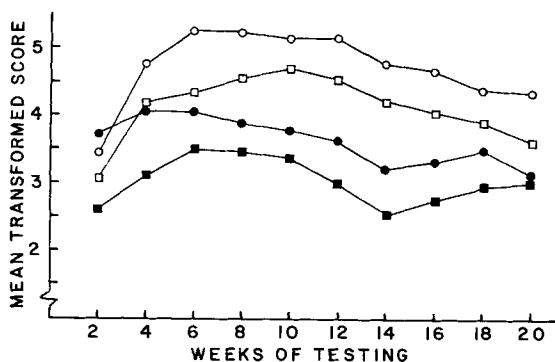

Fig. 4. Mean transformed frequency of social play averaged over the categories of approach, slap, wrestle, and bite. For symbols, see Fig. 2.

categories except for a reversal of the brooder-only- and mother-littermate-reared groups. The frequency of social play increased, then decreased, over weeks. The mother-littermate-reared kitten's social play peaked at about 4–6 weeks of testing (12–14 weeks of age), then began declining at 8 weeks of testing (16 weeks of age). Social play began declining at about 12 weeks (20 weeks of age) for both groups of brooder-reared kittens and at about 14 weeks (22 weeks of age) for the mother-only-reared kittens. (See Fig. 4.)

Trial Blocks were also significant for the categories of lowering the ears, sideways stance, and social piloerection. They all began declining after the 1st session. Withdrawal and defensive behaviors were generally consistent until the 10th week of testing when they began declining. Social sniffing gradually increased up to the 17th week of testing before leveling off.

Finally, no significant differences between groups were found with social looking and social defensive behavior. The only significant group difference with social sniffing was that the brooder-only-reared group sniffed more than the mother-only-reared kittens.

Discussion

The results of this study indicate the importance of rearing and testing conditions when assessing the influences of social isolation on the behavior of juvenile domestic cats. The motor movements used in object play did seem the same in all kittens, although the frequency was different between groups, testing conditions, and Groups \times Testing Conditions. Although the motor movements seemed similar (except for frequency) among all kittens in object play, the socially-oriented movements of the littermate-deprived kittens were generally atypical and often stereotyped. The one major characteristic that both littermate-deprived groups seemed to have in common was that they did not appear to know how to play, or that they were not aware of play versus aggressive signals. The littermate-deprived kittens displayed frequent biting and their claws were generally extended during most of their social contacts. (Bekoff [1972] noted that littermate experience is necessary in the control of biting behavior in canids.) Normally, if a kitten bit too hard or fought too vigorously, the other kitten

would vocalize a high-pitched shrieking cry and attempt to escape. Littermate-reared kittens, upon hearing the cry, would usually withdraw and either reapproach or wait for the stimulus animal to initiate another play bout. In the littermate-deprived kittens, however, the cry and escape attempt only intensified the behavior of biting and fighting. These observations support the notion that littermate experience is important for the acquisition of social communication skills as West (1974) suggested, and that the determinants (or functions) of social play are more complex than those for object play.

Although these general differences were observed between object and social play overall, each group seemed to display some idiosyncratic play patterns in the various testing conditions. The mother-only-reared kittens were generally hyperactive. When tested individually, this hyperactivity was oriented toward objects, leading to enhanced object play. However, when they were tested socially, the hyperactivity was directed toward the stimulus animal. This hyperactivity appeared to begin when these kittens were separated from their mother (experimentally weaned) at 6 weeks of age. (Their mothers had not begun to wean them at this time.) When they were separated from their mothers at 5 weeks of age (for 15 min) they displayed significantly more frequent distress cries than kittens reared in all of the other groups (Guyot et al., in press), yet they displayed the least amount of locomotor behavior (unpublished data). When they were weaned at 6 weeks of age they cried loudly for 2 weeks, became hyperactive, and lost about 20% of their body weight (even though they had been lapping milk and eating soft food before they were weaned). Observations indicated that these kittens remained hyperactive, even in their cages, throughout testing. During individual testing they were so active it was often difficult to follow their behavior. During social testing play bouts were fast and furious. Some of these kittens would jump on top of the stimulus animal with legs and claws extended; they would then dig their claws and teeth into the stimulus animal, wrestle shortly, then jump away as quickly, run around the room, and jump on the stimulus animal again. They even attacked the stimulus animals on the shelves and ramps, occasionally knocking them off. In the other groups, kittens were rarely observed in contact-play on the shelves. The mother-only-reared kittens would often sit in front of the stimulus animal, raise their paw high in the air with claws extended, and slap the stimulus animal several times hard and fast. Finally, while the stimulus animals continued to initiate some of the play bouts throughout testing, they spent most of their time withdrawing or defending themselves, both of which seemed to intensify the attacks.

The brooder-only-reared kittens displayed enhanced social behavior, but not object play (although they did display enhanced random running when tested individually). Because their hyperactivity was mostly oriented toward the stimulus animal, they were described as being hypersocial or hypergregarious. They frequently displayed stereotyped postures when approaching the stimulus animal. They would approach the stimulus animal in an arched-back, piloerected, sideways posture (generally described by Fox [1974] as an offensive-defensive threat). When they reached the stimulus animal they would stop and begin touching (or almost touching) the stimulus animal. They would also sit in front of the stimulus animal and touch it (or almost touch it) several times. This social touching was similar to the "tentative touching" observed in the development of these subjects, where they would touch (or almost touch) the walls, the brooder, the wire mesh, and the like, in their rearing cage. When the

stimulus animal withdrew, the brooder-only-reared kittens would follow, touching and biting the stimulus animal from behind. When the stimulus animal withdrew to a shelf or ramp, the brooder-only-reared kitten did not pursue. This may have affected the amount of play we observed in these kittens.

Wrestling often amounted to the brooder-only-reared kitten throwing its body on top of that of the stimulus animal, rather than rough-and-tumble wrestling. Its slapping of the stimulus animal was often interspersed between "space slaps," where it would simply be slapping out into space (or almost slapping the stimulus animal). Similar space slapping was also observed during the development of these brooder-only-reared kittens, where they were observed sitting in their rearing cage slapping out into space. Finally, these kittens often licked the stimulus animal and would "knead" them with their claws as if they were scratching a carpet.

The brooder-littermate-reared kittens were socially hypoactive when compared to the kittens in the other groups. These kittens were more closely housed with their littermate during infancy than the mother-littermate-reared kittens in that they did not have an opportunity to explore without their littermate. However, few stereotyped behaviors were observed and their social play generally mirrored that of the mother-littermate-reared kittens, except for lower frequency. These observations again appear to indicate that littermate experience is necessary in order to develop appropriate social play patterns, and also that the amount (or quality) of littermate experience may determine the amount of social interaction with other kittens.

The social play of all the kittens eventually declined, although the decline was delayed somewhat in the brooder-reared groups as well as in the mother-only reared group. This is in contrast to Koepke and Pribram's (1971) stressed group that peaked earlier than normals. The decline in social play of the mother-littermate-reared kittens at 16 weeks of age is identical to West's (1974) naturalistic data and Koepke and Pribram's (1971) laboratory data. Why social play declines is not yet fully understood. Rosenblatt and Schneirla (1962) reported that male androgens are being secreted at about this time, even though the males do not mate until they are about 8 months old. If the decline in social play is linked to hormonal changes in both male and female kittens at about this time, it might explain why identical declines are found in both restricted and free-ranging domestic cats.

Although the effects of early isolation on object and social play behavior of the juvenile kitten was the main theme of this study, the use of multiple categories of behavior indicates that when multiple categories of behavior are measured simultaneously, different group effects may be obtained on the different categories. For instance, the mother-littermate-reared kittens displayed more grooming, resting, and carpet-scratching than kittens in all of the other groups during both individual and individual-social testing. Apparently, depriving kittens of their mother and/or littermates debilitates these behaviors. The brooder-reared kittens rarely went up on the shelves or ramps, although the brooder-littermate-reared kittens did attain higher ramps than the brooder-only-reared kittens. A similar finding was obtained by Seitz (1959) with adult cats which had been weaned and isolated at 2 weeks of age. When compared to kittens weaned and isolated at 6 or 12 weeks of age, the early weaned groups showed the most stress on a ledge, required the greatest number of tests before they would jump, and jumped the fewest number of times. Frequently, the brooder-reared kittens in this study were observed sitting on the shelf in their home cage. They

also developed paw placement at the same time in development (about 4 weeks of age) as did the mother-reared kittens (personal observation). This suggests there were no gross perceptual-motor deficits in the brooder-reared kittens. Why early isolated kittens prefer to stay on the ground is yet to be determined.

Not only did these brooder-reared kittens not go up on the shelves or ramps, but habituation was difficult for the brooder-reared kittens throughout this study. During the 1st few weeks of testing these subjects slapped vigorously at every object they contacted. One subject did not move from the wooden platform (under the ramps) for 3 weeks. After slapping at the carpet on the floor several times, the kitten cautiously walked out on it. While the brooder-reared kittens were generally fearful the 1st few weeks of testing, the mother-reared kittens began object play immediately upon entry to the playroom, even though it was a novel environment.

The brooder-reared kittens would also dishabituate immediately with any minor change in the playroom. A sliver of wood from one of the shelves became an object that the 5-month-old brooder-reared kittens slapped at. When a videotape camera was placed in the observation window, the brooder-reared kittens froze until it was removed, whereas the mother-reared kittens continued to play. Whether the habituation difficulties resulted from the lack of a mother during rearing, the lack of exploratory opportunities, or their interaction (because the mother-reared kittens had both; Guyot et al., in press) cannot be determined from this study. Although the object play of the brooder-reared kittens eventually equaled that of the mother-littermate-reared group (when they were tested individually), habituation to novel stimuli and novel environments continued to be a problem for the brooder-reared kittens well into adulthood.

Finally, the littermate-reared kittens displayed the most looking (orienting) and the most frequent vocalizations during individual testing but not social testing. This result may have been due to some prolonged effects of separating the kittens from their littermates. These 2 groups did not differ in the frequency of their vocalizations (distress cries), produced by separation from their rearing condition during infancy (Guyot et al., 1980). These differences may provide some indirect support for West's suggestion that littermate experience is important for maintaining friendly social relations among members of a litter.

In summary, the results of this study suggest that social play and object play are affected differently by social isolation. In addition, the effect of social isolation upon the frequency of object play depends on the testing condition, that is, individual or social. However, although some effects of social isolation may be testing-condition specific (e.g. object play frequency), others may be consistent across testing conditions (e.g., self behaviors, shelves, and ramp behaviors). Although all of the kittens displayed appropriate object play movements (differing only in frequency), littermate experience is apparently necessary to learn social communication skills, and to learn appropriate patterns of social play. These findings suggest that the determinants (or functions) of social play are more complex than the determinants (or functions) of object play in the domestic kitten.

Notes

¹The complete operational definition for each category of behavior may be obtained by writing the 1st author.

²The significant *F* values for the analysis of variance on each category may be obtained by writing to the 1st author.

The authors wish to thank Sharon Curtis Conrad for her assistance in conducting this study.

References

- Bekoff, M. (1972). The development of social interaction, play, and metacommunication in mammals: An ethological perspective. *Q. Rev. Biol.*, 47: 412-434.
- Egan, J. (1967). Object play in cats. In J. Brunner, A. Jolly, and K. Sylva (eds.), *Play—Its Role in Development and Evolution*. New York: Basic Books. Pp. 161-165.
- Fox, M. (1974). *Understanding Your Cat*. New York: Coward, McCann & Geoghegan.
- Guyot, G. (1975). Early experience and motivational effects on the development and maintenance of patterns of play in *Felis catus*. Unpublished doctoral dissertation, Colorado State University.
- Guyot, G., Cross, H. A., and Bennett, T. L. (1980). Early social isolation of the domestic cat: Responses to separation from social and nonsocial rearing stimuli. *Dev. Psychobiol.*, 13: 309-315.
- Kirk, R. (1968). *Experimental Design: Procedures for the Behavioral Sciences*. Belmont: Brooks/Cole.
- Kling, A., Kovach, J. K., and Tucker, T. J. (1969). The behavior of cats. In E. S. E. Hafez (ed.), *The Behavior of Domestic Animals*. 2nd Edition. Baltimore: Williams and Williams. Pp. 482-511.
- Koepke, J. E., and Pribram, K. H. (1971). Effects of milk on the maintenance of sucking behavior in kittens from birth to six months. *J. Comp. Physiol. Psychol.*, 75: 363-377.
- Konrad, K. W., and Bagshaw, M. (1970). Effects of novel stimuli on cats reared in a restricted environment. *J. Comp. Physiol. Psychol.*, 70: 157-164.
- Kuo, Z. Y. (1960). Studies on the basic factors in animal fighting: VII. Interspecies coexistence in mammals. *J. Genet. Psychol.*, 97: 211-225.
- Leyhausen, P. (1973). On the function of the relative hierarchy of moods. In K. Lorenz and P. Leyhausen (eds.), *Motivation of Human and Animal Behavior: An Ethological View*. New York: Van Nostrand Reinhold. Pp. 144-247. (Originally published 1965, B. A. Tonlein, translation.)
- Rosenblatt, J. S., and Schneirla, T. C. (1962). The behavior of cats. In E. S. E. Hafez (ed.), *The Behavior of Domestic Animals*. 1st Edition. Baltimore: Williams & Williams. Pp. 453-485.
- Seitz, P. (1959). Infantile experience and adult behavior in animal subjects: II. Age of separation from the mother and adult behavior in the cat. *Psychosomat. Med.*, 21: 353-378.
- Snedecor, G. W., and Cochran, W. G. (1967). *Statistical Methods*. 6th Edition. Ames, Iowa: Iowa State College Press.
- Thomas, E., and Schaller, F. (1954). Das spieler optisch isolierten, jungen Kaspar-Hauser-Katze. *Naturwissenschaften*, 47: 557-558.
- Welker, W. I. (1961). An analysis of exploratory and play behavior in animals. In D. Fiske and S. Maddi (eds.), *Functions of Varied Experience*. Homewood, Illinois: Dorsey Press. Pp. 175-226.
- West, M. (1974). Social play in the domestic cat. *Amer. Zool.*, 14: 427-436.