

Seasteading: A Practical Guide To Homesteading The High Seas

Patri Friedman (with Wayne Gramlich)

June 9, 2009

Contents

Contents	iii
I Introduction	1
1 Preface to this edition	2
2 General Introduction	3
3 Reader Notes	7
3.1 Technical Detail	7
3.2 Political Agnosticism	7
3.3 Reader Commenting	8
3.4 Focus On Small	8
II Why?	9
4 Why Introduction	10
5 Why we need new societies	11
5.1 Three Stories	11
5.2 Real Groups	12
5.3 A Big Idea	14
5.4 Pioneers And The Need For A Frontier	15
5.5 Cost of bad government	16
5.6 Global crisis	16
5.7 Further Reading	18
6 Why They Belong On The Ocean	19
6.1 Disclaimers	19
6.2 Land = Crappy Government	20
6.3 Sea = Better Government	22
6.4 Misc. Points / Implications	23
6.5 Why Live On The Ocean - Summary	27

7	Why they should be approached our way	28
7.1	Why Incrementalism	28
7.2	Technological Realism	29
7.3	Transparency	30
7.4	Openness	31
7.5	Realistic Compromises	31
8	Why Summary	33
III	Review	34
9	Current	36
9.1	Floating Homes	36
9.2	Sailboats	38
9.3	Cruise Ships	38
9.4	Cruise Condos	39
9.5	Oil Platforms	40
9.6	Islands	40
9.7	Sealand	41
10	Attempted	43
10.1	The Freedom Ship	43
10.2	Aquarius Project	43
10.3	Minerva Reef	44
10.4	The Isle of Roses	45
10.5	Cortes Bank	45
10.6	Laissez-Faire City	46
10.7	Celestopia	46
11	Proposed	48
11.1	120 Acre City	48
11.2	Alexandisle	49
11.3	The Pelagic Project	49
11.4	New Utopia	50
11.5	The Venus Project	50
11.6	Spar Buoy	51
11.7	Ballard's Ocean Watch Tower	51
11.8	Reed Ship	51
11.9	Atlantis Project	51
11.10	Seascape	51
11.11	Triton City	52
11.12	Ocean Base One	54
11.13	Poseidon Undersea Resort	54

12	Historical Hacks	56
12.1	Gambling Ships	56
12.2	Pirate Radio Boats/Platforms	57
12.3	Havenco	58
12.4	Women On Waves	59
IV	Ocean Environment	61
13	Ocean Introduction	62
14	Waves	64
14.1	Ocean Wave Basics	64
14.2	Tsunamis	65
14.3	Rogue Waves	65
14.4	Wave Height	66
14.5	Calamity	67
14.6	Avoiding Waves	68
15	Wind	70
15.1	General Circulation	70
15.2	Ill Winds	71
16	Currents	75
17	Politics	77
17.1	Political Situation	77
17.2	Political Approaches	89
17.3	Feb. 2009 Meeting	95
18	Piracy	98
19	Biofouling	99
20	Ocean Misc	101
20.1	Sewer Ice	101
20.2	Upwellings	103
V	Structure Designs	104
21	Design Intro	105
22	Underwater	106
23	On The Water	109
23.1	Sailboat Fleet	109
23.2	Big Boat	110
23.3	Simple Platform	111
23.4	Pneumatically Stabilized Platform	113
23.5	Cargo Containers	114

23.6	Breakwaters	116
24	Above Water	120
24.1	Pillar Platform	120
24.2	Tension Leg platform	122
24.3	Semisubmersible	122
24.4	Floating Spar Platform	122
24.5	SWATH	124
24.6	Used Oil Platform	125
25	Structure Design Issues	126
25.1	Fixed-Position vs. Free-Floating	126
25.2	Breakwaters vs. Pillars	126
25.3	Modularity	127
25.4	New or Used	128
25.5	Protocol Suite	128
25.6	Structure Size	129
25.7	Materials	129
26	Structures: Summary	133
VI	Infrastructure	134
27	Infra Intro	135
28	Power	137
28.1	Energy Storage	138
28.2	How much do we need?	141
28.3	How much can we make?	142
28.4	Power Conclusion	153
29	Water	154
29.1	How Much Water Do We Need?	154
29.2	How Much Water Can We Get?	157
29.3	Other Considerations	162
29.4	Water Conclusion	162
30	Food	163
30.1	Importing Food	163
30.2	Growing Plants	164
30.3	Raising Animals	170
30.4	Area Requirements	171
31	Defense	172
31.1	Against Pirates	172
31.2	Against Navies	172
31.3	Prevention, Not Cure	173

32	Transportation	174
32.1	Staying Still	175
32.2	Moving	175
32.3	There and back again	178
32.4	Transportation Summary	179
33	Shelter	180
34	Communications	181
35	Appliances	184
35.1	Heater	184
35.2	Air Conditioner	184
35.3	Refrigerator	185
35.4	Hot Water Heater	186
35.5	Stove	186
35.6	Oven	187
35.7	Washing Machine	187
35.8	Dryer	188
35.9	Dishwasher	188
35.10	Vacuum	188
35.11	Lighting	189
36	Facilities	190
36.1	Infirmary	190
36.2	Shop	191
36.3	Kitchen	192
36.4	Common Areas	192
37	Government	193
37.1	Universal Human Rights	194
37.2	Government By Corporation	196
37.3	Polycentric Law	197
38	Waste Disposal	198
38.1	Types of Waste	198
38.2	Disposal Methods	200
38.3	Political Considerations	205
38.4	Polluters	205
38.5	Environmental Regulation	206
38.6	Example Waste Systems	207
38.7	Waste Summary	207
VII	Making Money	208
39	The Market	209

<i>CONTENTS</i>	viii
40 Business Models	211
40.1 Market	220
40.2 Cruise Ship Condos	221
41 Open Source World Library	226
VIII Making it Happen	228
42 Low Road vs. High Road	230
43 Ways That Don't Work	235
44 Areas Of Incrementalism	237
44.1 Size and Population	237
44.2 Financial Realism	238
44.3 Sovereignty	239
44.4 Distance	240
44.5 Implementation Incrementalism	240
45 Our Proposals	244
45.1 TSI's Proposed Timeline	245
45.2 TSI's Proposed Strategy	250
45.3 Something to Breakwater	260
45.4 Ephemerisle	260
46 How You Can Help	266
IX Misc Topics	268
47 Internet Discussion Groups	269
48 Intentional Community	270
49 The Word Seasteading	271
50 Architecture	272
51 Seasteading Haters	273
52 Seasteading In Poetry And Fiction	275
52.1 Poem: The City In The Sea	275
X Further Questions	279
53 Web FAQ	281
54 Book FAQ Intro	282

55	General Questions	283
55.1	I want to seastead! How can I prepare? (expanded)	283
55.2	Why did you choose to patent your seastead designs?	284
56	Concerns	286
56.1	Why is it so expensive?	286
56.2	Why do you think you can get freedom without interference? States will never let you be free!	287
56.3	Who is going to move to the middle of nowhere?	288
56.4	Why would anyone vacation on a seastead instead of a resort?	289
56.5	Pirates will get you!	290
57	Alternative Strategies	292
57.1	Why not just buy a boat?	292
57.2	Why not just buy an island or part of a third-world country?	294
57.3	Why not a used or abandoned oil rig?	296
57.4	Why should libertarians follow this approach?	296
57.5	Why not just hide?	301
58	Bad Consequences	303
58.1	Seasteads will enable cults to operate without interference	303
58.2	Seasteads will attack each other	303
58.3	It's just a bunch of rich guys wanting even more freedom	305
XI	Finale	307
59	Final Summary	308
60	Acknowledgements	309
61	References	310

Part I

Introduction

Chapter 1

Preface to this edition

The book you are reading is in draft form (perhaps eternally). We believe in transparency and immediate feedback, so we'd rather make something imperfect available right away than wait until it is polished. Also we'd rather work on adding ideas and content than on making it look perfect, so it will always be a little rough. If you'd prefer a slick presentation, there are lots of failed and inactive projects listed in the Review section which were better at hiding their warts. Some of them still have websites.

The first version of this book was written in 2002-2003, when the primary author (Patri) had neither a job nor a family. It then languished for a number of years while he had both. Then we got a big break: on April 15th, 2008, we received \$500,000 of seed funding from PayPal founder Peter Thiel to start a non-profit which we called The Seasteading Institute. Patri became Executive Director, and on July 29th, 2008, left his job at Google to work on seasteading full-time. This means more time available for writing, and a much more rapid evolution of our ideas.

Over the 5+ years since this book was first written, our thinking has evolved based on reflection, discussion, and new information. Some of these changes have made their way into the text, but due to limitations on the time available for writing, many have not. We believe that the text will catch up quite a bit during 2008-2009, but it will always be a bit behind our latest thinking. Fortunately, thanks to modern Print On Demand technology, new printed copies will always reflect the latest text.

Some of the key things we'd like to change when we get more time are:

- Structure Designs: Talk about more structure designs: multi-spar platforms and flat boxes (the later either in the doldrums or protected by breakwaters). We no longer believe that dumbbells are the best structure, we think there is a lot to be said for flat boxes in the doldrums, even for early-stage ocean settlements, and for larger multi-spar platforms. We are also reconsidering ships as a transitional option for the short-term.
- Making It Happen: Modify to reflect the creation of TSI and our latest thoughts about realistic business models and incremental paths.
- Making Money - Emphasize aquaculture & medical tourism ("The killer app for seasteading" ?) more strongly as top business models.

Chapter 2

General Introduction

*Mark Twain: "Buy land. They've stopped making it."
Seastealers: "Production Resuming."*

In this book, we'll demonstrate that a combination of technologies has finally given the lie to Mark Twain's famous line about the real estate business. Imagine the tremendous possibility of being able to create new acreage on the vast and empty oceans. The environment may be less friendly, but the increased freedom will appeal to a motivated minority who are fed up with terrestrial politics. These aquatic pioneers will settle civilization's next frontier through the unusual merger of green technology and free enterprise. Once there, they will experiment with new social, political, and economic systems, adding much-needed variety and innovation to the stagnant business of government.

As the earth's population steadily increases, so does the pressure to open new frontiers. While the oceans have long been used for transportation, this book is an extended thought experiment about how they could support permanent settlements. Considering these issues will be invaluable no matter which way humanity next expands. In particular, the ocean bears some definite similarities to space: the final frontier, which will surely be an important part of our near future.

While we're practical-minded and most of this book is dedicated to the **how** of seasteading, it's crucial to also explain **why** people are interested in small-scale sovereignty. In perhaps the most vital section, we'll outline the economic theory which suggests that ocean-based societies will actually work **better** than terrestrial ones. The relative ease of moving around entire buildings on the water means that political units will be dynamic, and so governments must be responsive and efficient or they will lose citizens. This effect will work automatically to improve institutions, regardless of the specific political system chosen. The ocean is not just the last open frontier on Earth - it is the perfect setting for a competitive market in governments .

For background, we'll review the conventional water-based lifestyles like floating homes, sailboats, cruise ships, and oil platforms. You'll also learn about some of the other ways people have successfully leveraged international waters for political freedom, like the european pirate radio movement of the 60's and 70's. We'll describe some of the scores of colorful new-country projects proposed and attempted over the years. While their ideas are

wide-ranging, including ships, reefs, spars, hexagonal cells, reeds, and tetrahedrons, they all share one thing in common - utter lack of success.

While this is an unfortunate history, we'll explain how we've learned from these past mistakes. Far from being dreamy-eyed utopians, we are serious planners with realistic principles for bringing this strange vision to life. This realism dictates an incremental approach, modest political goals, reliance on mature technology, self-financing, and a willingness to make compromises.

Before planning such a venture, it behooves us to understand the ocean environment. This includes fearsome waves like the so-called rogues, known as the "Monsters of the Deep". Scientists are finally acknowledging that this deadly phenomenon is not just an old sailor's tale. Contrary to what you may expect, tsunamis, high winds, and small-scale pirates will prove to be little danger. The tangled morass of international maritime politics and law is a far greater concern. While current nations are likely the greatest challenge to this new way of life, we'll sketch some promising solutions. We can't reassure skeptics completely, but there are reasons to be hopeful.

Once our goals, motivations, and obstacles are understood, we can examine designs for meeting them. We'll cover a wide variety of structures for living on the ocean, from boats to pillar platforms to undersea habitats. We'll also examine some of the basic design choices which must be made. These include whether a seastead should be free floating or fixed in one place, whether to use breakwaters or pillars to stop the waves, how to make floating-cities modular, and whether to purchase new or used structures. With these considerations in mind, we'll present more detail on our preferred design, the spar platform. This structure avoids the massive energy of ocean waves by keeping its platform above them and its flotation below. In between is a thin pillar which presents little cross-sectional area to the waves.

For the engineers and home power hobbyists, we'll outline how to provide the amenities of civilization on a floating platform. From our unique angle, we'll review the field of self-sufficient technology like solar panels, wind turbines, reverse osmosis, satellite internet, and hydroponics. Along the way, we'll debunk the myths that floating cities can be cheaply and effectively built from a material called seacrete or powered by OTEC generators.

However, solving these engineering challenges is meaningless unless we can solve the substantial business challenges as well. Sure, with enough money the ocean can be made habitable. But where will it come from? How will seasteads make money? Who will want to live there? Is there a big enough market? The lack of a good incremental plan has been a major flaw in other ventures, so we must address these crucial questions with a plan for getting from here to there through a series of realistic steps.

Figure 2.1:

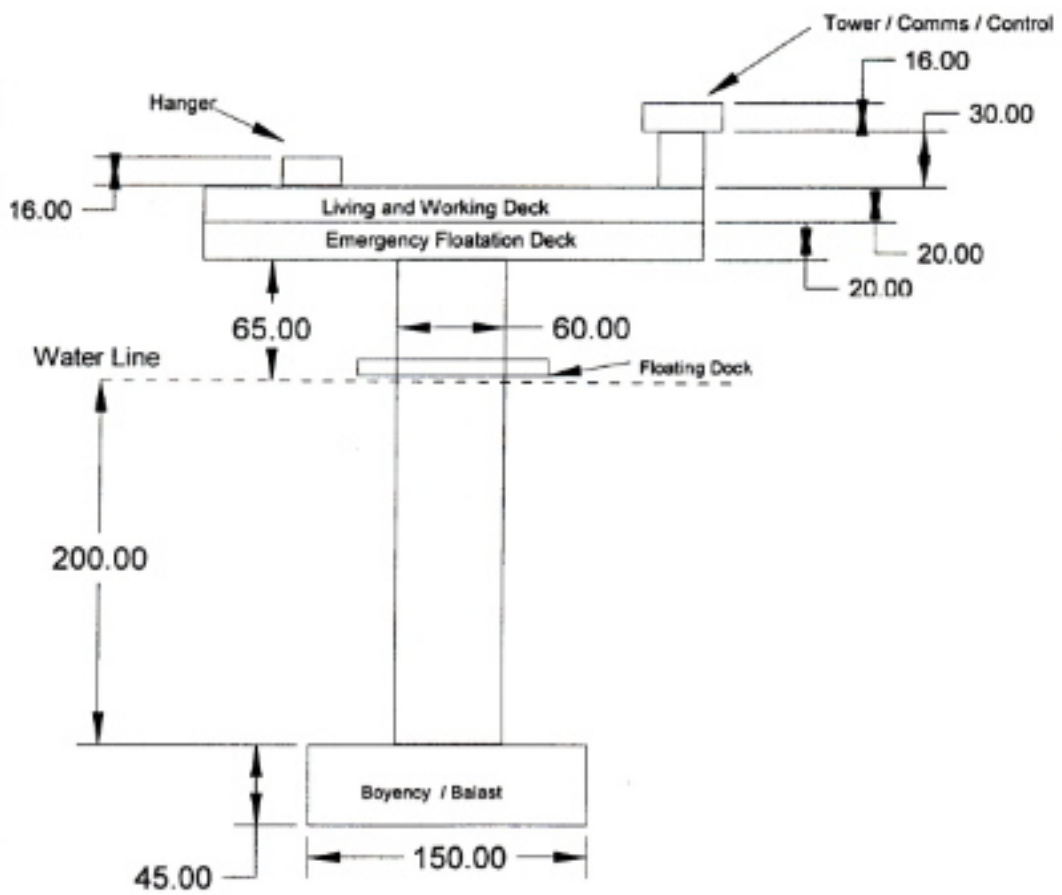

Figure 2.2:



Chapter 3

Reader Notes

3.1 Technical Detail

We must note that this book was not only written to entertain and inform, but as a practical guide and a compendium of our research. These two purposes require very different levels of detail, and so we've had to compromise.

At some points, the casual reader may find the level of detail high enough to only interest those who are actually designing or implementing such systems. Rather than getting bogged down in the numbers, feel free to skim. While we know it can be boring at times, please reflect that our diligence is an indication that our ideas have been well-researched. The world is full of visions, but making them into reality requires spending a lot of time on the mundane details.

More technically inclined readers may find our level of detail inadequate. Calculators at the ready, they cry "Forget Review and Motivation, where are the blueprints?" (or perhaps DXF files nowadays). If this book consisted of a complete design for every system onboard, no one would read it (if it was ever finished). Such readers must console themselves with the thought that a more readable book will hasten the spread of our ideas and thus the progression to a stage that involves DXF files.

Our main goal is simply to make sure each potential problem can be solved and get a feel for the solution. Detailed design can wait until someone starts a business and hires engineers.

3.2 Political Agnosticism

While the authors have a libertarian viewpoint, we want to stress that seasteading is politically agnostic. We're attempting to describe (and create) an enabling technology for small-scale sovereignty. This will give many different groups the autonomy to experiment with their theories. We find it very satisfying to be empowering all minority political groups, not just advancing our own vision.

Since this technology enables many alternative societies, some of them will be very, very different from each other, so we're mostly trying to give an overview of the common elements. We do have to make some occasional assumptions about the type of society to do this. Being libertarians, it is most natural for us to make libertarian assumptions. For the non-libertarians, rather than getting annoyed when you see political beliefs you disagree with,

try to focus on the fact that this technology will give you too a chance to show that your ideas can work in practice.

3.3 Reader Commenting

This book evolved from the internet tradition of collaboration and many:many communication, rather than the traditional one:many paradigm. Rather than simply being written and then published, drafts have been available online at every stage. For most of the book's lifetime, it had a mechanism for adding user comments (written by Patri). Thus the book has been a continuous dialogue between authors and readers, and many changes have been made as a result of commenter feedback.

In late 2007, we transitioned to a new website and a new authoring system for the book, and disabled commenting (which by that point had attracted a lot of spam). Our priority right now is to revise and publish the book, but we also intend to re-enable comments at some point, using a third-party commenting system.

3.4 Focus On Small

In this book we tend to focus on smaller seasteading, thus giving short shrift to technologies like nuclear power plants and OTEC. That's because getting started is the most important stage, and it's the challenge we face right now. By the time there is an ocean city big enough to need an OTEC generator, the seasteading movement will be big enough to have plenty of ideas of its own - some borne from experience which we don't yet have. We just want to get the ball rolling and seed the discussion with some initial thoughts and research, so we can someday get to that point.

Part II

Why?

Chapter 4

Why Introduction

We hope that many readers will immediately see the appeal of tackling humanity's next frontier, but we some may be mystified, asking: "Why would anyone want to go live on the ocean?" Until you understand why this will make the world better, the details will be of little interest. So we'll start by answering these questions:

1. *Why should we seek to create new societies at all? What's wrong with the ones we have?*
2. *Why seastead - is the ocean really the best place to experiment with new societies?*
3. *Why seastead using our approach?*

We'll answer them in very different ways, however:

1. We'll mainly punt on this. After all, who doesn't get frustrated sometimes with government or politicians? Instead of discussing the failures of democracy in detail, we'll just provide some brief evidence that many different groups are dissatisfied with current societal options and looking for a new frontier to try new things. We'll also provide some references for those interested in digging into the details of why government so often works so poorly.
2. Here is where we believe we can make a real contribution, with a new way of looking at government efficiency which suggests simple reasons why politics sucks now and how it can be made to suck less. This theory suggests that the ocean-based societies can have the least sucky governments the world has ever seen. However, they must leverage the ocean's unique qualities, otherwise they will fall into the same pitfalls as current countries.
3. While we will have plenty to say here, none of it will be very profound. It's merely the application of common sense to an area (founding new countries on the ocean) where it has been sadly lacking. Still, while our approach seems obvious to us, each of our tenets has been broken by other projects, so we feel it's worth laying them out!

Chapter 5

Why we need new societies

In this section, we will attempt to address the first question:

Why should we seek to create new societies at all? What's wrong with the ones we have?

5.1 Three Stories

The Pioneer

"Another great project, destroyed", sighed Carl, as he tossed the last 2x4s from his 3-story observation tower into the bonfire. His campmates, clad in paint and luminescent wire, danced, drummed, and drank in a circle around the blaze. It was the night of the Burn, and as always, he felt down. He knew some people loved the ephemeral nature of the festival, but to him it always seemed like a waste. So much creativity, so much hard work, all to be burned or torn down or at best packed and taken back to be put into a garage until next year. It had been so much fun to put the camp together: make showers and tents and set up generators and solar panels. But he wanted to build things that lasted, have art and creativity and vision and community be a lifestyle, not just a vacation. If only there was someplace where Burners could build a permanent Black Rock City and bring that spirit of art and adventure into their everyday lives. . .

The Environmentalist

Judy felt frustrated as she left the city council meeting. Her proposal to levy fines on recyclables left in ordinary trash seemed to her like such a reasonable idea, why did it ignite so much argument? Americans generated such sickening amounts of rubbish - all she wanted was to help cut down on it a little bit. "For a town that was supposedly environmentally conscious, they are awfully close-minded around here", she thought. She remembered that article she'd read about a Costa Rican ecovillage. It would be so relaxing and inspiring to live somewhere where everyone was of the same mind about not polluting the Earth. They could serve as an example to the rest of the world that you didn't have to damage the environment to live. But it ? If only there was a place that was sustainable and civilized. . .

The Pacifist



Glen clicked off the news angrily. Another day, another half-dozen deaths from that quagmire in Iraq. And that was just US soldiers - who knew how many innocent Iraqi citizens had died? What he hated most was that he was paying for those bullets, paying for those bombs. Sure, he hadn't voted for Bush, but the IRS took his tax dollars anyway. And not like the damn Democrats were doing much about all that military spending. It seemed like everyone in DC was on the take. One person just couldn't make a difference in a country this size, not unless he was a billionaire or some kind of internet-activism genius. If only he could live somewhere where he only paid for things he approved of, or at least got to choose where his money went, he'd be so much happier...

5.2 Real Groups

Do people like Carl, Judy, and Glen really exist? Those with an inborn pioneering spirit need only a mirror to answer that question, but others may take more convincing. Here are some actual groups which seek the autonomy to live under and experiment with different political, social, and economic systems than currently exist. There is a longer list in the Review chapter.

- The environmentally conscious seek to live sustainably and demonstrate that they can prosper while doing so:

The residents of these future cities, throughout the world, will show by exemplary actions that people of different races and divergent political, religious,



cultural and social beliefs can live and prosper together while also being good stewards of the earth, respecting, and thereby benefiting all inhabitants and ecosystems of the planet. (Celestopia)

- Libertarians want low taxes and regulatory freedom (Atlantis1994, New Utopia, etc.).

There are tax benefits: no federal tax on corporate profits, no state corporation tax, no social security tax. And any open sea facility is a free port. You can bring in any raw materials and ship out any finished products, without paying tariff duties. Outside government jurisdiction on the open sea, there are no regulatory agencies to contend with. You can dispense with the expense and bother of excessive paperwork, forms, and reports. You won't be ordered to waste your time appearing before government bodies. Licenses and permits will be things of the past. Government litigation and harassment, and the uncertainty caused by changing laws, regulations, and interpretations will be eliminated. Fisher1985, pp. 48-49

- Those interested in space view seasteading as the right intermediate step. As Peter Thiel has said, "Seasteading is the penultimate frontier".

If we are going to colonize space, it is best to colonize the easiest space first...Living in colonies at sea will teach us many crucial lessons about life in space. The isolation, self-sufficiency, and political autonomy of sea colonies are the same as those of space colonies. Both types will impose many of the same requirements on their inhabitants...The Moon is a harsh mistress; we would be wise to learn these early lessons while still in Earth's gentle lap.

Savage1992 pp. 23-24

If humankind is to survive, I see no alternative to expanding outward into space. And this doesn't just mean settling on other planets and moons. They will be just as vulnerable to doomsday weapons as the Earth, and there aren't enough of them to insure that some will survive an Armageddon. Only a large number of communities well dispersed in the volume of space seems likely to have a chance...The establishment of such communities space would constitute

a Golden Age of new-country formation in the next few centuries. Those who gain experience in the new-country field now are the most likely to be ready to seize the new opportunities when they arise - or to see their children and their children's children in a position to do so.

Strauss1984 p. 47

- Drug users care deeply about the freedom to ingest whatever chemicals they desire (Island. In many current societies, their hobby comes with the risk of substantial jail time.
- Individuals who are Environmentally Intolerant (EI), such as those suffering from Multiple Chemical Sensitivity, seek environments with minimal contamination from human chemicals:

Waterfront property offers some of the cleanest air anywhere by virtue of the high rate of ambient air exchange afforded by ocean or lake breezes. Even regions with relatively bad general pollution levels enjoy orders of magnitude cleaner air along the shore, as long as there are regular breezes. Unfortunately, few people can now afford such property -especially those who need it most. A floating home offers a potentially unlimited amount of waterfront real estate with no land cost. You can have as much as you can afford to build. There are no surrounding lawns and trees to generate pollen, no roads with cars to generate pollution -though, of course, boats are still a pollution issue albeit far less than automobiles.

Hunting

5.3 A Big Idea

Perhaps at this point you are wondering where we fall on the list. Personally, your author's views definitely match the "libertarian" label. But don't be deceived into thinking that seasteading is just a means to libertarian ends. While we began exploring it as part of trying to achieve our own vision of an ideal society, it turned out to be a much, much bigger idea.

There are many perspectives on what would make a better world and how to get there. Not surprising, since people have different dispositions, experiences, culture, and ideas. Yet current political systems are few in type and number, because they don't currently allow these different perspectives to be tried out. Instead, the ideas just get endlessly debated. Seasteading is an enabling technology to let people try out all these ideas about new forms of social organization. This will result in a diverse ecosystem of alternative societies (as we'll explain in more detail in the next part of "Why?")

The ability to experiment with new societies will produce both benefits to the pioneering seasteaders and to the world: seasteaders will be able to choose a society which is in harmony with their values, and each society will serve as an experiment, to learn if its beliefs work in practice. So individuals will be able to live their personal ideal lifestyles, while increasing our collective wisdom about social organization. Talk about a win-win!

Nor is this a small benefit. Government is one of the largest sectors of the world economy, yet it has benefited the least from technological development. The last major breakthrough was representative democracy, with the early adopter being the USA in 1776. Think about it - we get new car models every year, new electronic devices pop up every time we go to the store, but we only get new types of government every few hundred years! We'll discuss

why this is in the next section, but for now, just think about what an enormous drag this moribund industry is on the world, and how vastly our lives could be improved if government became more local and innovative.

5.4 Pioneers And The Need For A Frontier

Cast your mind back to the stories of Carl, Judy, and Glen. Each of them (and many of the real groups we listed):

1. Is unhappy with the current state of society.
2. Has a specific vision of what a better society for them would look like.
3. Is interested in building their lives around that vision.

It's easy to dismiss people like this as dreamers or whiners, but that would be unfair. Whiners are people who only have (1). Dreamers have (1) and (2) (although their visions are often impractical, since they are thought of in the abstract). But we cannot call merely dreamers or whiners those who see problems in society, have specific proposals for how to build a better society, **and** who would (if given the opportunity) join a group of like-minded people to create such a society.

These visionaries deserve better, for they are the social entrepreneurs who pioneer new ways of life, and are a key part of the evolution of human society. These people still exist in the modern world, and they still have plenty of ideas about what ails society and how it might be cured. But there's a problem: They have no way to implement or test those ideas.

The United States was set up for the states to serve as such experiments, in a system called "federalism". Each state could have different laws, and people would choose where to live based on what they wanted, and how the laws worked. Switzerland still works partially this way today, with competition between its cantons and a weak central government. But nowadays most government in the rest of the world (certainly in the United States) is implemented at the federal level, and even the states are far too large for easy experimentation. Traditionally, there was always the outlet of the frontier - trying out new societies using unclaimed land. But this no longer works because we have no frontiers left on land - every bit of dirt on the globe has been claimed by an existing government.

So society's valuable pioneers are left expressing their ideas uselessly in bars, blogs, and books, proposing better systems that will never be. Many turn their talents to business or academia, where good ideas are (sometimes) rewarded. A few become successful activists, and have some tiny positive impact on our fundamentally broken political systems. Most get frustrated and burn out and learn to focus on their own lives, where they can make a real difference. But deep within them still lurks the urge to blaze a new path, their pioneering spirit dimmed but not forgotten.

They've had a rough century - it's time to turn things around.

(This reminds us of the current situation vis-a-vis public education in the United States, where creative, active, playful children are labeled as "ADD". Trapped in the factory schooling system, doing obviously useless tasks, the energy and impatience that can make a great entrepreneur or scientist leads kids instead into trouble. Sometimes they recover. Sometimes they do not. As with pioneering, any system that transforms a valuable skill into a dysfunction is one with room for some major improvement.)

5.5 Cost of bad government

In order to get a handle on the magnitude of the problem, we need to zoom out and talk about the economy, rather than individuals. (But please keep in mind that the economy is just a way of summarizing parts of the lives of many people. What these economic growth numbers mean is whether parents can afford to send their kids to college, what quality of medical care people get, and whether their time is spent pursuing dreams and passions or just fighting to survive as subsistence farmers.)

(Insert Gwartney Graph)

A lot of arguments have been made for the value of government spending, but they don't seem to hold up to economic analysis. At least, in the first world, government spending is sand in the gears of progress. There is a strong linear relationship among OECD countries where the higher govt spending, the lower GDP growth. At 10% of GDP, the growth rate is 6%/year. At 50%, as in the EU, it's 2% a year. It's important to point out that these numbers aren't based on some imaginary libertarian utopia. These are real statistics drawn from real first-world countries over the last 40 years. If anything, I think they underestimate what a new society could accomplish.

(Exponential growth doesn't change things quickly, but as we can see from looking at the western world since the Industrial Revolution, or China in the last couple decades, over time it has an incredible power to transform the lives of vast numbers of people. For example, currently, per-capita GDP in the EU is \$35K/year. In 50 years at current spending levels, they'll be making \$100K/year, which is not bad, but if they could cut their government to 10% of GDP, they'd be making \$675K/year.

For those of us taking the long view, maximizing that exponent is crucial to the development of our species. Sure, money has diminishing marginal utility. But there are some big problems unsolved. Everyone in this room has a hereditary genetic disease. It takes many decades to progress, but it has a 100% mortality rate, that kills 100,000 people a day. It's called aging, and a cure is possible - but expensive. One big problem. Space / one planet is another.

5.6 Global crisis

When the first version of this book was written, in 2002, the United States (our home country) was a different place. Despite the dot-com bust, things had been pretty good for a couple decades. But the years since have not been good, due to two major international incidents, and two counterproductive responses.

First came the tragedy of September 11th, 2001, when ??? People perished in a terrorist attack. But the greater tragedy was how our nation responded. A thirst for blood that only cared about attacking Muslims, not whether they had anything to do with terrorism, which led us from Afghanistan (which actually had a connection to terrorism) to Iraq (which had essentially none, less than most countries in the Middle East). A new definition of patriotism that included unlimited spending on beefing up what was already the most powerful military in the world (and totally unsuited to the challenges of 21st century warfare) and excluded dissent. Security experts have testified that most of the response to 9/11 is mere "security theater", wasting money on appearances while accomplishing nothing.

And worst of all, our freedoms and civil liberties - the very things which make America a better place to live than most countries in the world - taken away in the name of protection. It's hard to overstate the irony, or stupidity, of this "strategy". The nation's leaders used

the opportunity, not to rally America into unity against a common enemy, but in a massive grab for that which government always wants to take from the people - power. And so, in claiming to "fight back" against the terrorists, we lost our way as a nation.

But that was just the first half of the game. The red hats wreaked their damage on our freedoms, and eventually, the country got outraged, and in November of 2008, the blue hats swept into power with control of the Presidency and both houses of Congress. Unfortunately for us, they too were handed a crisis, and you know what that means - a pretext to fearmonger while grabbing for power.

The response from the blue hats was the "New New Deal", the largest increase in spending, debt, and government control of the economy since the Great Depression. Just as economists later showed that the New Deal was actually harmful to recovery, not helpful, this massive (and misnamed) "stimulus" is a massive waste of money. We don't have time to explore the complicated issue of how governments should best deal with recessions now, but we'll summarize it by saying that the economists supporting and designing the stimulus are not experts on it, and the few experts on macroeconomics and recessions believe that Keynesian stimulus in the form of spending has little theoretical and no empirical backing. Macroeconomics is one of the least well-understood economic fields, yet also the most politically relevant. This results in economics being used to justify whatever politicians want to do, rather than guiding sensible policy.

The response is worse than counterproductive - by wasting money on make-work projects when we are already in a recession, the bill is likely to prolong and deepen the recession. Not only that, but we are incurring huge deficits which significantly increase our national debt and future tax burden.

But it gets worse. The United States is considered to be the safest borrower in the world, and the US Dollar the best currency, hence the status of Treasury bills and dollars as the reserves of choice for central banks. This demand for our currency keeps it strong, which enables us to buy things from the rest of the world at a discount. And the demand for our government debt keeps interest rates low - the lowest in the world - which means the interest payments on our national debt are minimized. But like any borrower, our credit rating is based on our financial situation. The more we borrow, the more we spend, the more we waste, the more we start to look like we might not be such a risk-free investment after all.

The world has already begun to shift away from the dollar as the sole reserve currency. Our debt remains quite strong (low interest rates), due to a "flight to safety" from the financial crisis. But there is a limit to the world's appetite for our bonds. As our deficits skyrocket to unprecedented levels (graph), the increased supply of bonds will lead to an increase in interest rates. This will increase the servicing cost on our debt, which will require an increase in taxes, which will slow our economy yet further. The US faces the small but real risk of an economic apocalypse, with massive dollar devaluation and perhaps even a sovereign default.

And even if things do not get that far, the measures taken to prevent it - high taxes, perhaps wealth taxes, inflation, capital controls - will make the country a far worse place to live. The blue hats are taking advantage of the financial crisis to wreak havoc on our economy. (To be fair, the red hats had solidly started down the same path already)

Two very different crises. Two somewhat different political parties. Two horribly counterproductive responses, each wrecking what they claimed to be saving. If you believe, even after reading our suggested references, that the US response to 9/11 increased our national security, or that the US response to the financial crisis will be good for the economy, then I guess it's true that you can fool some of the people some of the time. But for those of us

who shake our heads in disbelief at the stupidity of national policy, and seethe with anger at the charlatans who are supposed to protect our interests, it has been a truly dark decade.

The need for a new frontier and new ways of organizing a society has never been more urgent.

5.7 Further Reading

To do justice to the question of why current societies work poorly, and how they could be made to work better, would take a shelf of books, at least. We're going to cover our unique contribution in detail in the next section. For those of you interested in digging into the literature, here is a quick survey of some of the sources that we've found most influential.

Rummell book on death. Summary: In the 20th century, 61 million people died in war. 83 million were killed by their own governments (almost all Communist), by famine, genocide, or murder. Individual homicides? Only 8.5 million. As Voltaire said: *"It is forbidden to kill; therefore all murderers are punished unless they kill in large numbers and to the sound of trumpets."*

Machinery of Freedom (David Friedman)

Game Theory and the Social Contract (Ken Binmore)

Mancur Olson - stuff

Myth of the Rational Voter (Bryan Caplan)

Economics In One Lesson (Henry Hazlitt) ?

Chapter 6

Why They Belong On The Ocean

Next, we'll turn to the second question:

Why seastead - is the ocean really the best place to experiment with new societies?

We initially chose the ocean as the best place to experiment with new social systems because it is the only unclaimed area left on earth - and space is still a bit expensive. (You can read more about how the world is currently divvied up by the powers-that-be in the Politics section). After considering the matter, however, we were led to the unexpected conclusion that the ocean's unique features will lead to a revolution in the quality of government. We'll first analyze why terrestrial governments are so bad, and then show how things are different on the ocean. These ideas were first explored in Patri's Dynamic Geography paper [PFriedman2004].

6.1 Disclaimers

There are some important caveats we must make before presenting our theory on why terrestrial democratic governments perform so poorly.

The first is that this is by no means a complete taxonomy of the failings of democracy. There are other significant, endemic problems, such as those analyzed by the public choice school of economics, and discussed in the previous section . We have specifically chosen to explore the reasons below because they are the things that we can change, so they most directly illustrate the effect our changes will have. But since they represent only part of the problem, we admit that our changes will only alleviate some of the suffering caused by unresponsive, inefficient, and sometimes even murderous governments. We hope only to show that these reasons are significant enough that there is hope for seastead societies to work substantially better.

Second, it is truly said that democratic government is a terrible system, worse than any other except all those which have been tried. So before dissing democracy, we want to first acknowledge its rightful place as the reigning king of political systems. Our exploration of its flaws is not meant in any way to oppose its current widespread support and adoption, and we are delighted at its continued spread across the globe. Yet democracy is a relatively recent invention, and it was only a few centuries ago that it was a radical proposal, viewed by many as a hopeless utopian dream. It would be foolish to let our acknowledgment of its superiority over past methods blind us to the possibility of it being superseded by future forms of political organization.

Failed political experiments can have a terrible cost - just look at the mind-numbing body count of the 20th century's failed experimentation with communism . So our trials with these forms must be done cautiously, incrementally, consensually, and with great care to allow for non-tragic failure modes. Yet to refuse such experimentation would be to resign ourselves to never improving one of the areas most central to human progress and happiness.

6.2 Land = Crappy Government

With those disclaimers, let us consider government as an industry like any other. Citizens pay taxes, and in return they get government services. While there are a variety of reasons why this industry does a terrible (and sometimes horrific) job at serving its customers, we will focus on two of them.

High Barrier To Entry

The second problem is that the cost of entering the governing industry is incredibly high. To create a new government you basically have to win a war, an election, or a revolution. These are rare and difficult things. Economists call this a "high barrier to entry". While industries with low barriers to entry tend to be very competitive, with innovative firms competing to provide the best product, those with high barriers tend to consist of a few entrenched firms taking advantage of their position (an oligopoly). This is good for the firms (Warren Buffett, for example, specifically looks for such "trenches" when investing), but not so good for the customer. Currently, the difficulty of getting into the government industry dwarfs that of almost any commercial industry - if the barrier to entry in the automobile industry was this high, we'd all still be driving Fords. Even desktop computer operating systems, famous for its low level of competition, is not as bad.

Besides the general lack of efficiency and accountability which comes with an oligopoly, these barriers to entry are particularly hard on political minorities. After all, if the cost of getting into the governing business is very high, it will only be done for large groups of people. Contrast this with the ultimate New Economy business of creating websites, whose miniscule barrier to entry results in a vast array of options serving every conceivable niche (along with some unimaginable ones!)

High Cost Of Switching

First, the cost of switching service providers is very high, since it involves moving to another country. An expatriate must usually leave their job (and find a new one), sell their house (and find a new one), leave their friends (and find new ones), and deal with a new culture. Compared to the cost of switching cellphone providers, ISPs, cars, or insurance agents, this is gargantuan. So even if one feels poorly served, it's a great temptation to stay and hope things get better, or perhaps try to change them despite slim odds. The expense of moving reduces the potential impact of jurisdictional arbitrage (a fancy name for changing the system by voting with your feet, taxes, and/or citizenship). The result is that governments don't compete to do a good job, because they don't need to. Their citizens are trapped, which means their actions result in little market feedback, so they focus on exploitation instead of innovation.

Besides making sense theoretically, we can find evidence for this hypothesis in the real world. For example, tax rates on capital are generally lower than those on labor, because capital is more mobile. Switching cellphone providers is more difficult in the US, where

handsets are "locked" to one carrier, than in Europe, where unlocked phones are the norm. The result is that Europe generally gets better handsets, sooner (with rare exceptions like Apple's iPhone), and its cellular providers are more innovative (cite needed). Gamers can switch console systems much more easily than companies can switch office software, and so Microsoft's Xbox is considered much more innovative and user-friendly than its Office product suite.

One potential solution to the cost of moving is an information economy with digital cash, where people can work and maintain social networks from anywhere. This idea has been championed by hi-tech libertarians, and was described in the book *The Sovereign Individual* [DavidsonMogg]. While it has worked for a tiny number of individuals, most people's jobs involve some hands-on component. And current economic research suggests that the importance of physical colocation is increasing, not decreasing (hence why the newfangled tech industry is concentrated in Silicon Valley). And even when the information economy frees us from job-based geography, the other problems with moving (family, house, face-to-face contact with friends) remain.

Resulting Industry

When it is hard for new companies to form (barrier to entry), and hard for customers to switch (lock-in), you have an industry segmented into a bunch of local monopolies. Sound familiar? Government in its current form is exactly that - a geographically segmented monopoly. The natural result is for firms to focus on exploiting existing customers rather than innovating and competing for new ones. Act like bandits, not like salesmen. This industry is so badly structured that firms constantly steal from and occasionally even murder their customers, and still stay in business.

Taken together, we can see that governments do a poor job of serving their citizens, especially minority groups. it's an industry with little market feedback, little competition, little reason to perform well, and little opportunity for incremental improvement.

It is important to note that both of these are arguments about incentives based on systems-level thinking, and that they apply regardless of the political party in charge. One could argue instead that governments and websites are different industries because they attract different types of people, or have a different culture around them. While this viewpoint is natural, we think that in general such explanations are weak, and we instead take the attitude of the economics profession, which is that the first place to look for the causes of differences in people's performance is in the systems that organize them and the incentives they provide. The people in Germany in the 1930s and 1950s were not particularly different, yet they operated under very different political systems.

The debate is important because the different explanations lead to different recommendations for change. If the problem with democratic governments is just that the wrong group is in charge, the solution is to kick out their bums and replace them with our bums. If the problem with governments is that they are run by politicians and bureaucrats, the solution is reform that encourages other types of people to enter public service. But if the problem, as we claim, is that democratic governments have a set of systemic incentives to perform poorly, neither of the above will make much difference. Instead, we need a new system with better incentives.

We think the empirical evidence is on our side. The reins of power have passed through the hands of many bums of many professions, personalities, and parties, but little has changed since Mark Twain wrote To improve democracy, we must improve these systemic incentives. Fortunately, we can.

6.3 Sea = Better Government

When we build countries from modular collections of seasteads, we change both these characteristics.

Lower Barrier To Entry

Seasteading drastically cut the barrier to entry by opening a new frontier where small groups can form independent settlements. Instead of the trillion-plus dollars it's taking the US to enact a new regime in Iraq, groups will be able to start a new country for tens or hundreds of millions - many orders of magnitude less. And the group doesn't need to get it all at once either, they can add structures as resources and people become available. The result is to empower minority viewpoints of all types.

Lower Cost Of Switching

This is Royal Caribbean's Freedom of The Seas Cruise Ship, and the Empire State Building. To the same scale. It is no exaggeration to say that the ocean lets things as big as skyscrapers move around on a regular basis.

This feature of the ocean has already had an enormous impact - it's why we have global trade, but people don't seem to have thought about what happens if you build a country on the water. On the ocean, we can create modular, geographically flexible countries. It's a whole new paradigm compared to land - by detaching from one ocean city and floating over to another, you'll be able to leave your country, without leaving your house.

If existing countries followed our model, then the country of Georgia could be 1000 miles away from Russia in a week (not a made up number). Israel and Palestine wouldn't have to be neighbors - after fighting over how to divvy up the promised land, probably blowing some of it up, they could take their pieces and go their own way. New Hampshire might not have to be so close to Vermont! And any country whose laws were too oppressive would find its best and brightest melting away to grace some friendlier land - and taking their houses and offices with them.

To some degree, this already happens on land. Capital moves to where it can get the best terms - building new offices and factories instead of moving old ones, but it's the same idea. The United States was founded with the idea of federalism, competition between the states. Well, think of this as Extreme Federalism.

This dramatically lower cost of switching providers promotes market feedback. If the government announces an unpopular policy on Monday, by Tuesday there may be nothing left of the city but the capital building, overlooking a serene seascape of empty waves. If residents care deeply about the change, they can do more than just voice their opposition - they can act. Whether it is libertarians and taxes, drug users and drug prohibition, pacifists and military expansion, environmentalists and sustainability, a modular city will give its residents an unprecedented degree of control over their political affiliation.

Better Industry

Instead of huge, monolithic, unresponsive governments, we'll have many small, dynamic, innovative ones. Power will move downward towards the level of the smallest economically feasible platform (something like 10-100 people). We don't claim this will result in utopia, but it should increase the efficiency of any type of government.

These differences are intimately related to the difference between static and dynamic geography. You can grab dirt and hold it. Try to grab water, and it will swirl away. What little you capture will slowly evaporate. There is some deep truth to this metaphor. We believe that terrestrial governments control people because they can control territory and the immobile structures on top of it. On the ocean, control of the foundation has little relevance - a seastead can float anywhere.

6.4 Misc. Points / Implications

While these two industry characteristics are the biggest factors, there are a lot of other ways of looking at the advantages of seasteading.

Meta-System

Let's consider several different levels on which we could discuss politics:

- Policy. For example, a debate about whether to criminalize drug use, attempt to reduce the harm of use, or completely legalize it. What are the effects of each specific policy? Which does the most net good? Who is hurt, and who is helped?
- System. What types of policies does a specific political system tend to generate? For example, in a democracy, a special interest group can easily coordinate to influence legislation which benefits them, but costs everyone a little bit. If every consumer loses a dollar a year from a policy, it just isn't worth anyone's time to fight it. Hence we expect democracies to frequently produce policies which steal small amounts from many and give them to a few. And indeed, tariffs, farm subsidies, and bailouts, just to name a few, fit this model quite well. This type of argument is at a level of generality above any specific policy, and it can offer enormous insight at consistent errors made by current governments. But to fix those problems, we need to rise further yet.
- Meta-system. At the level we want, we think about the entire industry of government. What types of systems does it produce? How can it be changed to produce better systems (that is, systems which produce better policies)? What influences how well the governments of the world serve their citizens? How can we increase competition between governments? This level is the most abstract and the most complex, which can make it difficult to get a handle on, but if we can grasp that handle, it gives us the most leverage to change the world.

Now you can see why those who ask us which policies we want, or what type of political system we'd start, are missing the point. I mean, if you want to buy me a drink, I'll be happy to spout off about my personal theories for an ideal government, but that's not what this is about. We don't want to start a government or change a policy - we want to create a world with a diverse ecosystem of governments of different sizes, values, and cultures, trying different methods of social organization. To use the metaphor of a business, these levels are products, firms, and industries. People are asking about what company we'll start and what product we'll offer, when we want to create an entire industry.

As philosopher Robert Nozick wrote in *Anarchy, State, and Utopia*

Utopia will consist of utopias, of many different and divergent communities in which people lead different kinds of lives under different institutions. Some

kinds of communities will be more attractive to most than others; communities will wax and wane. People will leave some for others or spend their whole lives in one. **Utopia is a framework for utopias**, a place where people are at liberty to join voluntarily to pursue or attempt to realize their own vision of the good life in the ideal community but where no one can impose his own utopian vision on others.

That's what we're talking about.

Diverse Ecosystem

This industry will have many different firms offering different services to different markets. In fact, it already does - they are the countries of the world - but the variety in systems, sizes, and methods is currently quite low, because of the barrier to entry mentioned earlier.

After all, there is no single answer to the question: "What is the best government?", for many reasons:

- Different people have different values, which mean they want to live in a society with different goals.
- Making a good government is a very hard problem - even if a group agrees on goals, there is no simple way to construct a set of laws or institutions to meet those goals. Like any hard problem, it requires experimentation by many different groups trying many approaches.
- There is no perfect form of social organization, which means the search for a better system will never end. There will always be something new to try. This is especially true because technological change will mean new tradeoffs and options for government. This is especially true if, as seems likely, technology starts to change human nature itself.

Reset

One of the problems of government is that it tends to slowly grow power structures which become entrenched and cannot be removed. When a government agency makes progress on its mandate, it asks for the same budget so it can continue. When it fails to make progress, obviously it needs more money. The result is what some economists have called a ratchet effect which results in government continually growing in size and scope. It is no accident that most political innovation has happened on the frontier, where brand-new societies were being formed.

The economist Mancur Olson argues that this is a big part of how democracies function, and points to evidence that older countries, which have had time to grow the most special interest sludge, have the slowest economic growth, while those whose powers were shattered, such as postwar Germany and Japan, have the most economic growth. Similarly, newer industries grow faster than older ones, because they haven't accumulated these power structures which hamper change.

The modularity of seasteads provides a reset without a frontier (or, if you like, a permanent and omnipresent frontier). An entire government can be scrapped and started anew for any subgroup of its citizens, without them even needing to pack their bags - let alone shed blood. This will allow for much more frequent and less painful innovation, with new ideas

constantly building on old ones, and the technology of social organization will advance much more rapidly.

While the disassembly that we discuss will be painful and expensive, it should not often be necessary. In chess there is a saying "The threat is greater than the execution". The same applies to seasteads. The ability of a module to leave will enable it to win better terms for itself, even without exercising that right. It may be important for seasteads to actually leave on occasion, to prove that they can, but they should not have to bear the cost of leaving every time they want a political change.

Technological Solution To Political Problems

One of the great things about this idea is that it's a technological solution to a political problem. Humans are no good at changing human nature, and human nature, plus the nature of political systems, is why governments function poorly. Yet we are fabulous at solving engineering problems. Well, dynamic geography shows us that we can dramatically improve government merely by solving the engineering problems posed by seasteading. As cryptography makes it almost impossible to censor free speech and communication, seasteading will make it very difficult to exploit a trapped citizenry.

Code

Let's not forget that laws are information, just like code! The governing industry, like most modern industries, is built on ideas. Can you imagine if each of you had the same flexibility you do when programming to roll a new government out of pieces copied from old ones, plus a few new twists? Let's just copy our corporate law from Delaware - or the Bahamas. If we want the right to revolution in our seastead Constitution, I hear we can copy Article 10 from the Constitution of this fine state.

Show By Doing

And we're going to do it without proselytizing, without having to argue people around to our way of thinking, without needing to win any elections. We're going to do it by building an alternative and using it ourselves, and showing, through our lives, why everyone else should do the same. It's a put up or shut up approach to philosophy - kind of like the Free State Project.

Ocean Tax vs. Government Tax

The ocean tax is the extra cost of living in the harsh, corrosive ocean. The government tax is extra cost of regulation and wasted taxes. At the beginning, our ocean tax will be pretty high, and only the sectors with the highest government tax will be worth moving offshore - like medicine. But if we can, through economies of scale, get the ocean tax to be lower than the government tax for most things that most people do, then we get a world where everyone lives on seasteads, and we use the continents as farms and nature preserves.

It's worth noting here that the ocean tax is basically constant (decreasing), while the government tax is proportional to wealth, so over time, the balance tilts more and more in our favor. Maybe seasteads aren't cost-effective now - by the time Obama leaves office...

Incremental Secession

As history shows us, revolutions are bloody. It is difficult for power to change hands without a period of uncertainty in who has the power, and such periods can be extremely violent. This is a big problem for those of us who want to radically change existing political systems. As Arthur B writes:

This is a pointless thought experiment, but I think it gives interesting results. Assume that you gain political power in a country, and - before you become absolutely corrupted - try to turn it into a happy anarcho-capitalistic society. How would you do it?

The first approach is to dissolve the State. Tear apart the whole structure, leave your office and throw the key. Unfortunately, should you do that, the State will be recreated instantly, election held etc. Society is sensitive to hysteresis, it's not just the institutions that define how it works, it's also where you come from. By shutting down the State, you will just have quit your job not destroyed it. The second approach is to gradually transform the State by reforming it until it completely disappears. Unfortunately, this second approach has drawbacks. First, it is unethical, it makes you a criminal. Second, you are very susceptible to become corrupted by the power on the way, to encounter obstacles etc.

Fortunately, there is a way to combine gradualism and radicalism all in an ethical way (hooray).

The way to do it is to grant secession rights to every landowner. Most likely, few people will use that right at first, because the services provided by the states are needed, therefore they will voluntarily chose to stay in the State. Once this right is granted, you are not a criminal anymore! You can then engage in extensive gradual reforms with the ultimate check and balance that people can secede.

At first, secession would probably be used to create free trade zones, that require little protection. Later on it could be used for gated communities. Meanwhile, you'd try to do the best job you can to provide something efficient people want to stay in, with very little budget due to easy tax avoidance.

The key idea here, is that market will provide the best balance between incremental changes and radical transformation of society by letting people chose. Pragmatism dictates that people won't probably secede en masse, but their right to ensures efficient policies and satisfies any ethical concerns.

One of the downsides to seasteading is that it requires a relocation of civilization, building brand new countries on the currently empty oceans. While in many ways this is unfortunate, it also has its advantages - in a way, it implements Arthur's solution. If you work with existing countries, not only do you have to somehow convince those currently entrenched in power to give it up, but you have a transition that is complicated and messy. People really don't like power transitions, because of the potential for bloodshed.

But seasteading offers another way. There is no transition of power over any existing land or physical structure. Instead, we get an incremental movement as seastead cities grow and develop. People secede from traditional governments one at a time, and by physically moving to a new location.

6.5 Why Live On The Ocean - Summary

If the above was too new or abstract or confusing to make sense, don't worry about it. The key thing to take away is that we aren't just heading for a new frontier with the vague hope of finding a better way to live. We actually have good reason to think that ocean societies will actually work better than terrestrial ones.

Which is not to say that life on the ocean will be perfect - far from it. Most of the problems of life on land will come right along with us - how to find love, making money without selling your soul, the tricky balance between security and freedom, and how best to raise your children. But the problem of being part of a system so huge that you don't feel you can have any impact, with nowhere better to go, no way to get more autonomy for yourself or your community, no way to put into practice your ideas about better ways for people to live - that we can address.

Bad government is a big problem, it calls for a big solution. The bad news is, I'm proposing we rebuild our entire civilization someplace new! The good news is, if we do it right, in a modular way, we only have to do it once - dynamic geography will then ensure that it then stays a permanent frontier. We can have repeated bloodless revolutions where we reconfigure existing nations. And there's plenty of room, since the theory suggests that 70% of the planet and most of the rest of the universe (space too) have the properties for better government.

It may be the last frontier, but it turns out that the ocean is not a booby prize.

Chapter 7

Why they should be approached our way

When Patri was at Google, the procedure for launching a new product involved a long checklist of things to check and watch out for. Engineers found this list onerous, but the experts explained it quite simply: "Behind every item on that checklist is the flaming wreckage of some past launch." The items in this section may sometimes seem so commonsensical that they aren't worth repeating, but behind each one lies a failed project.

So while there is no single right approach to seasteading, there are certainly plenty of wrong ones. And what we've learned from the movement's (admittedly dismal) history has to a large degree shaped our philosophy. Because of this, explaining our approach goes hand-in-hand with identifying common points of failure and indicating how we think they can be overcome.

The root cause of most of these failures seems to have been lack of realism. So our solution is simply to be as pragmatic as possible about our vision. Realism is our philosophy's foundation, and more specific policies are just the application of realism to various areas. Important areas include incrementalism, politics, technology, and finances.

7.1 Why Incrementalism

The most basic part of our realism is that we believe in an incremental approach to every area of seasteading. This means breaking our ambitious visions down into small steps,



and taking things one step at a time. A cruise ship is not as exciting as a new platform design, diesel-powered generators are not as exciting as OTEC, and operating under a flag of convenience is not as exciting as being a member of the United Nations - but it can happen decades sooner.

We believe that a realistic approach to the difficult problem of nation-founding must be incremental. Large, successful things usually start out small and expand organically. Rome wasn't built in a day and a successful business leverages each stage into the next. Big things (cruise ships, skyscrapers, factories) do get built all at once at times, but they are almost always proven concepts that were first demonstrated successfully on a smaller scale. There were many two-story buildings built before the first three-story one, let alone the first skyscraper. If there was a nation-founder with the financial resources to jump the intermediate stages and create a vast floating city, it would already exist. After all, there are plenty of people ready to design and build one as soon as the multi-billion dollar check gets cut. Since no such *deus ex machina* appears to be forthcoming, we recommend humbler methods.

There are plenty of grand conceptual ideas out there, but we see a key link between **being grand** and **staying conceptual**. If you make the first step too high, you will never even get started, as the many participants who became frustrated with and dropped out of new-country projects can attest. Instead, we believe that the main focus should be on the current and immediate next stages, not on far-distant visions. Watch the path in front of you, not the sky, or you will trip.

We discuss many of the specific axes along which we can proceed incrementally under Making It Happen.

7.2 Technological Realism

Engineering a cost-effective structure to survive in the harsh ocean environment is difficult enough. Counting on unproven technologies will only make things harder. For example, several potential ventures [Savage1992, Celestopea, Nexus] have focused on the combination of two problematic technologies: OTEC and seacrete, which we feel exemplify the unrealistic "science-fiction" approach to floating cities.

OTEC, or Ocean Thermal Electric Conversion, is a technique to generate energy from the temperature difference between warm surface water and the cold depths. Unfortunately there is little practical experience with the technology, and it scales down very poorly. It's a promising technology for the future, perhaps for governments soon, but not at all applicable to small ventures now. Some projects have treated OTEC as practically free energy for ocean cities, when it is quite expensive indeed. We discuss it further in our Infrastructure - Power section.

If you dip a wire mesh in seawater and run electricity through it, a cement-like substance forms. Known as seacrete, many floating-city designs have been based on this wondrous source of free building materials. Unfortunately, there is a catch. The common cited figures for energy requirements are off by a factor of 40, and so the electricity costs far more than just buying concrete would, as we describe in more detail in the building materials section.

Seastealers will not make the mistake of counting on an impractical technology to make their vision happen. Our concept is a big enough jump already, and the fewer jumps we make along with it the better. So while necessity has prompted some novelty in our designs, they are firmly rooted in standard engineering techniques. You'll see us examining a number of cutting-edge technologies, yet planning to use very few of them on early seasteads. Our



power will come from solar panels, wind turbines, and fossil fuel backup generators, not OTEC plants. Reinforced concrete is an extremely cheap construction material, and we'll buy it from standard terrestrial sources. In short, our philosophy is to plan our initial designs around mature technologies and save the innovation for later iterations.

New technologies will be important to the long-term development of seasteading, and so we will discuss some of the key areas where we hope to improve on standard methods. But we must not count on any breakthroughs.

7.3 Transparency

A solid, realistic plan can stand criticism and review. It is the scams, the half-baked, the grandiose but insubstantial, which must hide behind a facade of mystery. In our experience, the less you see up front, the less there is behind. Sure, it's possible that behind the curtain lies a complex and well-considered plan which is being hidden for some legitimate reason, but the odds are heavily against it. If it looks like the emperor has no clothes, he's probably got goosebumps.

There is nothing wrong with playing the micronation game, imagining a country for fun. But the line between Micronation and genuine venture is a blurry one, in the minds of the principals as well as on their websites. Hinting at complex negotiations with mighty powers for far-off territory adds spice to projects on either side of the line. Yet the countless cycle of promises and failures cannot help but turn interested participants into weary cynics, exhausting the enthusiasm of each new generation. We'd much rather be open about what we have (now, a realistic plan, a rough design and a little financial commitment, later, we hope, a small but habitable prototype). We are trying hard to minimize the faith necessary, but there will be some, and we think honesty, not puffery, gives us the best chance to get it.

7.4 Openness

Related to transparency is openness - being public about our existence, goals, and methods.

A number of TSI community members have expressed concern about our policy of operating openly, stating our goal to create new governments on the internet and in public interviews. They worry that it could bring us to the attention of governments before we are ready, allowing them to quash our nascent movement, and suggest that it might be better to keep everything quiet until a large seastead community is operating. While attracting negative attention early is certainly a danger, we believe there are a number of significant advantages to openness:

- It allows us to work with public figures, like successful businesspeople and scientists, who would not be associated with a secret project that might get them in trouble.
 - It allows us to raise investment from individuals and institutions who are likely to require the safety of us being part of the existing global regulatory environment.
 - It gives us the greatest possible audience for our ideas. Many of the community members, including those who are concerned about our openness, found out about seasteading through our public website or media mentions.
 - It gives us the best chance to negotiate with governments in good faith. "Hell hath no fury like a bureaucrat scorned", as Patri's grandfather said.
 - It attracts people who want to openly create a new society which is part of the interdependent world, rather than those who want to make a hidden Galt's Gulch, cut off. This is important, since we think an isolated society is much less attractive, less likely to succeed, and more likely to go horribly wrong (see *The Beach*, *Bioshock*, *Lord of the Flies*. . .). The whole point of seasteading is not to hide - so let's be true to that principle from the beginning.

Let's also not forget that this is a movement where diversity is a core value. Other groups are welcome to create similar projects in secret, hoping to grow large enough to be in a better negotiating position before they are noticed by the existing powers of the world. We wish them the best of luck, but that is not our path - we seek to be the public face of this movement.

On the other hand, we don't want to take this too far and insist on radical honesty. We want to be open about our existence and long-term goals, but there may on occasion be specific elements of our strategy or predictions for the future that are better left unsaid for marketing purposes. However, we will be operating under a strong presumption of openness as a default. (Including being open about the degree to which we are open, as you can see!)

7.5 Realistic Compromises

While our goal is to change the world, we believe that compromise is an important part of the process. We accept that seasteads will not have full freedom to choose their own laws. There will be substantial limitations on what the rest of the world will tolerate. Like it or not, the first seasteads will be tiny fish in huge ponds, and if they make the sharks angry, they'll get eaten before they grow big enough to put up a fight.

For example, libertarian seasteads will probably be allowed to have low taxes and low regulation, but genuine bank secrecy may not be permitted because of worries about terrorist

money laundering. We think it's far better to get what freedom is possible than to fail because of a refusal to compromise. Environmental regulation offers another example where compromise will be necessary. Our political goals are a compromise as well in that we simply wish to be left alone by other states, we aren't seeking recognition, embassies, passports, and a seat in the UN like some projects.

This willingness to compromise does not mean that our new way of life offers no improvements on the old. It's just that focusing our efforts on a few changes at a time is the most effective way to succeed. Even with the limitations of reality, there are still plenty of incremental improvements that can be made to current social systems.

We specifically suggest drawing the line of compromise between local autonomy and actions that affect other governments. Zoning laws, legal system, drug use, health care, safety nets - all of these are areas that affect the local population. But there are some things that will impact the rest of the world. Pollution, money laundering, drug exportation, hiding fugitives, all of these harm other people or prevent existing sovereign countries from enforcing their own laws. While there will always be argument about where this line lies (is producing greenhouse gases at the same rate as other nations pollution?)

Chapter 8

Why Summary

The problems facing prospective nation-founders are undoubtedly difficult, as evinced by the movement's historical lack of success. They can be overcome **if and only if** we rationally consider our options, then produce a design which is politically, technologically, and financially feasible. For the reasons which we will outline in this paper, we believe that seasteading meets these criteria. While there is a lot of planning and hard work ahead, there are no substantial leaps of faith required. We think that this makes our vision unique.

We cannot over-emphasize the importance of the economic analysis about the governing industry. It would be a great shame to boldly homestead the oceans and have them turn into the same quagmire we are trying to escape. The other parts of our philosophy, and the rest of this book, all deal with implementation, with the **how** of seasteading. It is Dynamic Geography that tells us **why** this new way of life will be different than the old. We are realists, and we expect that living with the same humans will result in many of the same human problems. But different systems can result in quite different results with the same people. While we will never reach utopia, we think we can make some fundamental improvements to current social systems, and in the real world, that is plenty to strive for.

Now: on to the details.

Part III

Review

In order to set the stage, we'll discuss some of the previous projects and schemes for living on the ocean. These will range from the real to the attempted and the merely imagined. We'll also explore some of the previous precedents for people using the high seas for freedom.

Chapter 9

Current

Here are some of the current aquatic lifestyles from which seasteading can draw inspiration. They are a varied group, none quite like what we are imagining, but each with enough overlap to be worth studying.

9.1 Floating Homes

A floating home is exactly what its name implies - a house built on a floating platform. Typically these structures don't have any on-board propulsion, they consist of a home built on a hollow concrete box. There are many floating home communities in the USA, like Sausalito's Richardson Bay FloatingHomes. Patri attended one of their annual tours, and



has a report with pictures [FloatingHomesTour]. The Netherlands, a country which is 50% below sea level, also has a large number of floating homes. We were unable to find market statistics on how many floating homes there are worldwide.

This lifestyle typically start out as a clever technique for avoiding the high cost and restrictive codes of some housing markets, but inevitably the various government agencies figure out what is going on and start to enforce building codes, property taxes and the like. Eventually, the floating homes cost just as much as any other form of real estate in the area, although they remain much more picturesque.

Floating homes are designed for sheltered waters, so they don't need to worry about big waves. You might think this makes their design unsuitable for the ocean, but we will see later that there are some circumstances where this model is appropriate. Also, while many floating homes are built in conventional fashion by companies like [IMF], there are some unique and interesting exceptions.

In his original seasteading paper, Wayne Gramlich suggested building floating homes using two-liter bottles for flotation [Gramlich1999]. This would provide a very cheap foundation, although it is suitable only for calm waters. It turns out that Rich Sowa had already used this method to build a small island off the coast of Mexico which he operates as a tourist attraction [MotherEarth2001], [Sowa].

Artist Andrea Zittel built a concrete island home called the Pocket Property, and anchored it off the coast of Denmark. She describes the experiment in an interview:

I guess when I was working in New York I found that I was mostly drawn to these very small, contained capsules that would go inside of preexisting architecture. Moving to L.A. completely changed the scale of my thinking, and I started to become much more interested in creating environments, and much more sensitized to exterior spaces. So although it's kind of a leap, this piece really came out of the entire experience of moving back into suburbia. I started to think about how important it is, when you're living in that kind of an area, or when you live outside of the city - your land is so important to you. When I was looking for a house, it was much more important - the plot of land, and how big it was, and how it was situated - than the actual house itself. And I've also been really interested in how we create these little private universes.

When I drive down the street in my neighborhood, every single person's yard is landscaped to represent some fantasy of where they live, whether it be an alpine fantasy or a tropical fantasy or a desert fantasy. And they're all these totally separate little universes or environments that are completely honed in. So I've been thinking about that a lot, and how I could actually create a design for a feasible living environment that reflects the most important things that people look for. I guess the other thing, too, that I've been thinking about a lot is this whole sort of capsule living, and how especially out there it's more and more about creating your own bubble, your own capsule. You're in your house, on your property, and then you get in your car and you drive. And I go for the drive-through; I don't even want to get out of my car to eat or to go to the bank. Everything's drive-through, and it makes me feel very, very safe. But I also think that there's a certain sort of sadness to that too, a certain loss of civic life. It's a prototype for a particular type of lifestyle. But if I were to extend that vision I would say that it's possible that some day something like this might exist, and that people would live in these community spreads. I've been doing drawings of these, all lined up, almost like cars in parking lots. Almost like a

suburbia floating out in the ocean, so you're completely alone, you're completely autonomous, but you have also this sense of community within that. [PBSZittel]

9.2 Sailboats

Sailboats

An ocean worthy sailboat is definitely large enough to live in. Rather than buy a house on land, some people choose to purchase a sailboat and live onboard. Thus, when you go to a marina, there is a good chance that some of the boats in there are being used as full time residences [Moeller1977]. In many US marinas, live-aboards are limited to ten percent of all berths.

When the boat owner has the time and resources, they can undock from the marina and go sailing. Indeed, with enough savings, they can live on the interest and spend all their time traveling [Hill1993].

By carefully managing energy needs and using the right mix of solar cells, trolling generators, batteries, and a backup generator, is possible for a sailboat to be completely energy self sufficient [Rose1979].

The next step, of self sufficiency for food, is much more difficult for most sailboats due to limited solar area. However, using a combination of growing small amounts of food and scavenging local seaweed it is possible to reduce the amount of food you need to buy Neumeyer1982.

While a carefully outfitted sailboat is capable of surviving months at a time on the open ocean, eventually some consumable resource will near depletion, and the sailboat will have to return to land. Also the cramped spaces and human need for social contact make most people desire periodic visits to port. We'll discuss the pros and cons of this method in more detail later when considering designs.

In this category we also include [HouseBoats]. While they may not have sails, they are (unlike floating homes) designed to be mobile, although they are usually operated in sheltered waters so that they do not have to cope with significant waves. Most houseboats have all of the amenities of a modest sized recreational vehicle - kitchen, living room, bedroom, bathroom, etc. They are in fact the aquatic equivalent of RV's.

While most houseboats are used for recreational purposes, some people have moved into them on a permanent basis. For example, there is a small houseboat community called Knight's Landing on the Sacramento River. Discovery Bay and Redwood Shores, both in Redwood City, are two more marinas where houseboats moor in the San Francisco Bay. Europe, with its large network of navigable waterways, is home to many houseboats as well.

9.3 Cruise Ships

Cruise Ships

The cruise ship industry has been growing rapidly for decades. There are a number of different companies that provide vacation packages for people to board a cruise ship for a week or two. While the budget accommodations are pretty spartan, the deluxe accommodations are luxurious. Extensive food and entertainment are provided. Many cruise ships have on-board casinos so that patrons may gamble, an example of profiting from the freedom of international waters.

While cruise ships are large, ocean-worthy vehicles that can stand some serious weather, most customers do not like rough seas. Thus, a cruise ship will typically change its itinerary to visit alternate ports of call in order to sail around or entirely avoid a bad ocean storm.

Although a cruise ship can rightfully be considered to be a floating city, they are far from self-sufficient. The modern cruise ship is typically only capable of cruising for a week or two before its consumables need to be replenished. So while cruise ships support a significantly larger population than a typical sailboat, they can do so only for a limited time before they must return to port and replenish water, food, and fuel.

9.4 Cruise Condos

Cruise Condos

A new development in the cruise ship industry is the idea of full time residency onboard. While only one ship is currently operating, several more are planned. While these ships aren't doing any innovation in government, they definitely bear watching as an example of a full-time residential lifestyle on the ocean, and we are cheering for their success.

Residensea

The ResidenSea Corporation has built a \$265M cruise ship with 110 residences and 88 guest suites that allows wealthy patrons to live on the ship full time as it cruises around the world ResidenSea. It began cruising in March of 2002. Their waste policies are mentioned later. All residents were required to also have residences elsewhere - these cabins could not be used as a primary residence.

Unfortunately they targeted the ultra-luxury market just as the global recession hit, and for several years had troubles selling units. In late 2003 the residents bought the ship from the operating company to run it themselves. They report that sales have been increasing (although there are still many empty units). Still, it sounds as though the original financial backers did not get good results. Given that it's already difficult to get funding for a new type of venture which requires substantial capital, the ResidenSea result makes it even harder. Despite ResidenSea's failure, the idea has enough merit that several more cruise ship condos are being constructed.

Four Seasons

The Four Seasons hotel chain is building Four Seasons Ocean Residences. From the promotional material:

With Four Seasons Ocean Residences, you'll discover extraordinary places you never might have ventured, – or never even knew existed – always with Four Seasons finesse guiding your way. Anchored nearly 250 days a year – in ports from Antwerp to Zanzibar – you're free to spend your days exploring exotic, exciting locations. Then return to the familiar comfort of home.

On her maiden voyage, the Four Seasons will depart from the historic port of Helsinki and set forth on a two-year itinerary, painstakingly designed through in-depth research. Following the sun for optimal climates, the itinerary aligns with major world celebrations, giving you the most convenient home base for the 2012 London Olympics, Carnival in Rio and the Cannes Film Festival. Extended

stays in key destinations provide you with ample time for inland excursions – whether African safaris or Antarctic penguin-watching.

After the initial two-year schedule, the itinerary will be determined in part by Four Seasons residents themselves and confirmed two years in advance.

Statistics:

Gross Tonnage: 48,600 Overall Length: 720 feet (220 metres) Number of Decks: 12 plus Sky Deck Cruising Speed: 18.5 knots Residences: 112 Owner Guest Suites: 18 Butler/Staff Suites: 11 Maximum Capacity: 550 residents Typical Capacity: 120 to 250 residents Crew: 220 Builder: Aker Yards Projected Delivery: 2010 Public Space: 70,000 ft² Cost: \$3.7M (796 ft²) - \$39M (7,860 ft²) per residence.

Besides permanent residences, the ship offers timeshares starting at \$400K for 1 month/year for 50 years.

Orphalese

The "Orphalese" plans to launch in 2008. They are offering 200 permanent residences ranging from the 1,000-square-foot, 2-bedroom Pegasus Estate to the 3,700-square-foot, 5-bedroom Penthouse, which are available for full ownership. The 2-bedrooms start at \$1.8 million with \$30,000 in annual fees, while penthouses start at \$10 million with \$78,000 in annual fees.

9.5 Oil Platforms

Oil Platforms

Since an oil platform is towed into its final location, it is more like an artificial island than a boat. Oil platforms are currently quite expensive, sometimes costing as much as a billion dollars. This expense is reasonable since a single oil well can generate millions of dollars of revenue in a single day [Helvarg2001].

Since oil platforms are not permitted to move from their location, they must be designed to withstand some incredibly severe ocean weather. While they prove that it can be done, cost reduction by several orders of magnitude is required to make ocean living practical.

9.6 Islands

Islands

While not technically floating, private islands are often considered as a potential location for founding new societies. There is a substantial market for private islands [PrivateIslands], which can be found throughout the world. However, all of them are claimed by traditional jurisdictions, which have historically been loathe to part with their political control. As island real estate specialist Vladi Private Islands says:

– There's something special about a private island. An isolated piece of paradise, its beaches and forests yours alone to enjoy. A virtual private kingdom under the sun. While this is enough for most of us, for some, only a real kingdom (or republic, or principality, or ?) will suffice. For these folks, a private island is but a means to an end - the establishment of a new, independent country. But is such a thing really possible?



The short answer is a pretty conclusive 'no'. Since the early 20th century, every square foot of dry land on Earth has been claimed by at least one country or another, which pretty much rules out discovering an unmapped tropical paradise, planting your flag, and setting yourself up as the local sovereign. Similarly, existing countries are more than a little reluctant to part with pieces of their national territory, no matter the financial incentives offered.. [PrivateIslands]

9.7 Sealand

Sealand

The Principality of Sealand is arguably the most (perhaps the only) successful new-country project in recent history. It was founded in 1967, when Roy Bates, a pirate radio operator, moved into an abandoned WWII anti-aircraft platform called Rough's Tower. The platform was located about 7 miles off the British coast, which was then in international waters.

Several incidents have supported the Principality's claims of independence. Sealand fired warning shots at a nearby repair boat, who took King Roy to court over the matter. The

ruling was that the tower was outside of the court's jurisdiction. Later, some German men briefly seized the platform by force, and were captured in a helicopter raid. One was kept as a prisoner for several weeks, during which period the German government appealed to the British government for help. However, the British Foreign Office said that the tower was beyond their jurisdiction [Strauss1984, p. 132-138].

More recently, Prince Roy has retired, and Sealand was leased to a company called HavenCo for several years as a data haven. For various reasons, this venture failed.

Reader Bob Green writes:

Sean Hastings, one of the people behind Havenco, lived here in Anguilla for several years. we worked on a cryptography software project together. Although it may be true that terrorist concerns after 9/11 contributed to the shut down of HavenCo, i heard informally that other factors may have been more important: 1) not as much demand for government-free web hosting as they expected. 2) they partnered with the son of the original sealand founder and put him in charge of security. 3) the partner had all the guns and as the project hit problems, he just turfed the founders out. An interesting legal question is where do you go for contract enforcement when you are a micro-nation. Can you sign the contracts for your seasteaed in the UK/US where they are enforceable?

And reader Julian Egelstaff says:

I found your web pages while doing some reading on Freedom Ship. I noticed that you mention Sealand and Havenco on part of your site, and you mention that Havenco shut down over worries about terrorism. I read a recent presentation by one of the former principals of Havenco that suggests it had more to do with the people and organization not really being up to the task. I thought you would be interested....

Referring to Ryan Lackey's presentation at DefCon 11.

There have been suggestions of expanding Sealand by damming off and then draining an area around it. It will be interesting to see if this upstart country can continue to maintain its independence, and whether it can turn sovereignty into business opportunities. Sealand was put up for sale in 2007, and so far has had no takers [ABCNews200708].

Chapter 10

Attempted

Those who do not learn from the mistakes of history are doomed to repeat them, and so we have studied what little material exists about attempts at seastead-like ventures. We find some of the following quite illustrative. Note that the distinction between "attempted" and "proposed" (the next category) is somewhat arbitrary. Since most nation-founding attempts don't get past the drawing board, our standards for what constitutes an attempt are fairly low. Also, some of these attempts are still ongoing.

10.1 The Freedom Ship

The Freedom Ship

The Freedom Ship [FreedomShip] is a proposal for a mile long "City At Sea" for 40,000 people. The chief architect is an engineer named Norman Nixon. The folks working on this one have managed to generate an extensive amount of press coverage (including Popular Mechanics and the Discovery Channel) and enlist dozens of volunteers. Construction cost, unfortunately, is in the neighborhood of **ten billion dollars**. While the large size makes the idea newsworthy, it also makes financing extremely difficult. This is especially true when ResidenSea, which was approximately 1/40th the cost, could not sell all its units. It seems fantastically unlikely to us that anyone will finance such a large project until smaller ones have demonstrated that the floating condo concept is viable.

Indeed, no signs have yet been seen of this staggering sum, although the company has built an 11-foot long, 400 pound model, which puts them well ahead of the average project. A lack of transparency has been notable from the beginning, with interested but skeptical people complaining that their criticisms have all been deflected or ignored [Patri_FS]. However, rumour has it that they'll soon be selling copies of the huge amount of design work they've done. Only time will tell whether they can raise the funds for this gigantic project. While we are rather skeptical that it reach fruition in its current form, we would be delighted to be proven wrong.

10.2 Aquarius Project

Aquarius Project

Another well-publicized venture during the 1990's was the Aquarius Project, based on the book *The Millennial Project* by Mashall Savage [Savage1992]. An organization was created called the First Millennial Foundation, which later changed its name to the Living Universe

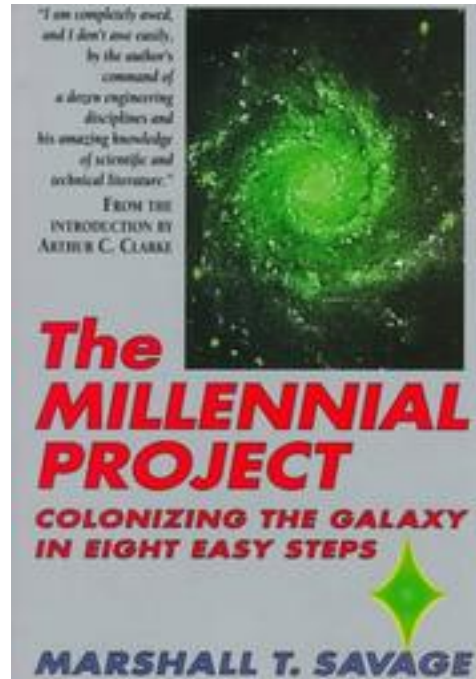

Foundation. Savage proposes building many large floating cities out of hexagonal cells made from a material called Sea-crete or alternatively Seament. They would be powered by OTEC generators, which operate on the temperature differential between surface and deep water. Income comes from mariculture, hydrogen, magnesium, and several other sources. Actually, only the first 100 pages of TMP are about Aquarius, and the remainder discusses the remaining 7 stages necessary to begin colonizing the galaxy. This is an excellent example of the viewpoint that ocean cities are a stepping stone to space colonies.

Unfortunately, while the book is stuffed full of technical information, the basic ideas behind Aquarius are at the very least ahead of their time. They may even be inaccurate. We discuss the flawed calculations behind seacrete and the currently nascent state of OTEC in more detail later, when explaining why those technologies are not currently part of our plan. In addition, Savage is overly ambitious, focusing on huge cities without any plan for starting with small ones. Unsurprisingly, without prototypes to demonstrate that the ideas were sound, there was not enough interest to build an initial Aquarius settlement.

10.3 Minerva Reef

Minerva Reef

A seamount is a not-quite island, an underwater mountain without enough oomph to make it to sea level. Like land, seamounts are geographically stable but politically problematic. They can act as breakwaters if they're close enough to the surface, which is quite useful since waves are one of the major dangers of the ocean. Also they can function as anchoring points or pillar foundations. However if they are raised above sea level, they are vulnerable to claim by land-based jurisdictions, as happened with the Minerva Reef. Since this incident

exemplifies the reasons why free-floating sea structures are better politically, we will recount it here.

Michael Oliver, a Las Vegas real estate millionaire, made several nation founding attempts. At one point he focused on the Minerva Reefs, 260 miles southwest of Tonga, which were conveniently outside the territorial waters of any nation and below water at high tide. Quite large, they seemed perfect as a foundation for a new, sovereign territory. His plan was to build them up with sand and create a new island and a new country, and he hired dredges from Australia in 1971. After six months, he proclaimed the independence of the Republic of Minerva, which issued coins.

The only reaction he got was from the Kingdom of Tonga, Minerva's closest neighbor. A box of supplies was dropped on the new land which said "supplied and maintained by the government of Tonga", an action said to be supported by other nations in the area. His Majesty then ventured to Minerva with a gang of convicts and a four-member band. They planted the Tongan flag, played the Tongan national anthem, and claimed the sandy patch for Tonga. After they left, the forces of nature did their work, and the sand of Minerva returned slowly to the ocean from whence it had sprung. [Strauss1984 pp. 115-117].

This is a classic example of the lengths to which nations will go to preserve their cartel status - even a worthless patch of sand is seen as competition. If a new nation is created on land (no matter how small or undesirable), it is likely that the nearest traditional nations will claim jurisdiction. It may be possible to negotiate a treaty, but that is likely to be expensive and prospective nation founders are unlikely to have much to bargain with.

10.4 The Isle of Roses

The Isle of Roses

The short-lived Isle of Roses offers another excellent example of the antipathy with which countries view nearby nation-founding attempts. As Strauss explains:

--
Giorgio Rosa was (or is) a professor of engineering in Bologna, Italy. In the early 1960's, he built a tower in the Adriatic Sea, in water less than 20 feet deep, about 8 miles off the coast of the Italian city of Rimini. This first tower was wrecked by a storm on February 13, 1965. A new one was built, with an area of about 4,000 square feet. It had a bar, a restaurant, a post office, a bank and a store, all surrounded by a promenade. The Italian authorities took no notice (since they only claimed 3 miles from shore as their territorial waters) until May 1, 1968, when the platform was declared to be an independent republic, whose official language was the artificial one Esperanto. The Italians invaded 55 days later, speaking vaguely of such things as "national security, illegality, tax avoidance, maritime obstruction and pornography." In the spring of 1969, Italian Navy frogmen dynamited the structure. At last report, Rosa did not plan to try again, saying darkly that "This country is all Mafia."

Mafia or not, this illustrates the extent to which existing countries are willing to brush aside written law if they think a new-country project has the potential to seriously inconvenience them. [Strauss1984, p 129-130]

10.5 Cortes Bank

Cortes Bank

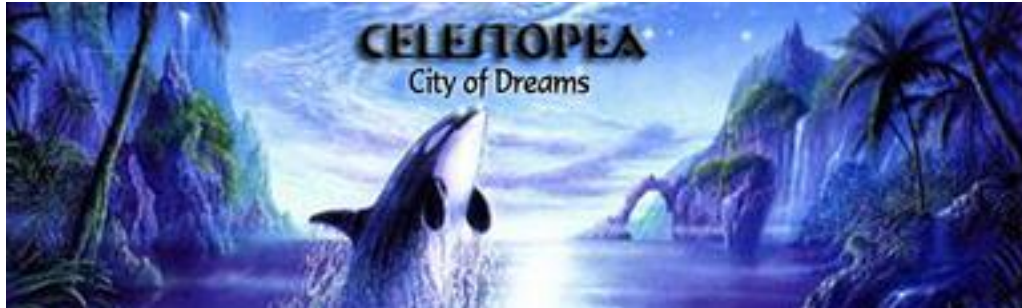

Another brief example of the greed of traditional nations relates to the Cortes Bank, which lies off the coast of San Diego:

The USS Abalonia was a concrete cargo ship, constructed for the purpose of becoming an independent nation. The company which built it hoped to anchor it in rich shellfish beds on the Cortes Bank, 100 miles off the coast of San Diego, and claim jurisdiction over the area. Shortly after the Abalonia's launch in 1969, it foundered and sank, nearly killing the crew. In the wake of the Abalonia fiasco, a second company began plans to build a platform on the Cortes Bank and declare it the nation of Taluga. The US government quickly gave notice that the Cortes Bank, as part of the continental shelf, fell within its jurisdiction. [FootnotesToHistory]

10.6 Laissez-Faire City

This Ayn Rand-inspired project began as an attempt to found a modern-day Galt's Gulch. The organizers placed a declaration of sovereignty and request for a host nation in several high-profile publications, including *The Economist* (6/10/95, 8/12/95). Media such as the London Times and BBC World Radio covered the story, and 3000 people from 108 different countries contacted the founding Trust.

Unfortunately, the response from potential sites was less enthusiastic. The principals followed several leads without finding an acceptable locations (although their standards may have been a bit high - the shallow shoals which LFC turned down would be more than sufficient for our purposes). With no land in sight, LFC transitioned to seeking freedom in cyberspace, developing tools for digital freedom.

Eventually, due to personality problems and poor business practices stemming from one of the founders and major financiers of the project, LFC was dissolved. A long, detailed, fabulous review can be found in ScamDog2002 Their early experiences exemplify two of our claims about nation founding: that there is a large potential market, and that it is extraordinarily difficult to get sovereignty from existing nations.

10.7 Celestopia

Celestopia

Their webpage states:

- Dedicated to creating ecologically balanced, floating ocean communities and terra-formed, permacultured islands, grown from the mineral-rich waters of the tropical oceans. We wish to share our creations and technologies to help expand the unity, prosperity and quality of life, of all the people of Earth. -

This currently active project is based in Costa Rica, and the fact that its principals were willing to relocate there suggests that they are serious. Their website contains a timeline, including the steps they have completed. They are currently in the stage where they are beginning to need financing, which is a very difficult time for any project. While they pitch the seacrete + OTEC combination which we later debunk, they also acknowledge that seacrete is not ready for prime time yet and plan to start with ferrocement. Their designs are partly based on the Monolithic Dome Institute [MDI], which is another good sign, as the MDI has helped construct hundreds of concrete domes. They believe, as do we, in teaching by example rather than rhetoric. Unfortunately they seem to be looking mainly to donations for initial funding. It seems to be the most mature environmentally motivated project.

Chapter 11

Proposed

Now that we have covered the existing strategies for living in the middle of the ocean, as well as some methods that have been attempted, it is time to visit some ideas that so far remain merely visions. Some of the designs listed below are more practical than others. This list could be quite long, and is merely a selection of some of our favorites:

11.1 120 Acre City

Here is a comment on a floating city post somewhere on the internet that represents, to me, exactly what is not needed to advance the movement:

Floating city is very feasible. I am a naval architect designed a whole city that can float in very deepwater and do not heave for severe storms. I have a USA patent. My original design has eight wings each 100m x 600 m and it has a center of attraction at the middle with school, auditorium, police, hospital, city hall, court, what not. One wing is dedicated for aircraft landing. Wave energy is utilized for power; all cars are electrical with public transport system. There is fishing, water purification, gardens, agriculture what not. There is a Disney land and there is a Las Vegas on board. It is a cool place for vacation, stay, live and work. Micro Soft, Bill Gate, can keep their employee there and develop software industry there. All the best expert would be on board and live in a place of solitude and peace and enjoy and more productive. No crime and well balanced place. It is completely shelf sustained. Any one seriously interested can contact me at..

Now, his city may be very nice. It may even be a good design of an artificial island city. But our (very rough, very preliminary) cost estimates are \$250/ft², which is about a hundred million bucks an acre, which puts a price tag on his 120 acre dream of twelve billion dollars. Even MSFT or Bill Gates is going to flinch at that number. A design like this is solving an irrelevant problem: that of designing a 120 acre city.

This problem is irrelevant, because at the point where there is enough money to build and enough people to fill a 120 acre city, the naval architects of the world will be lining up outside the door of whoever is organizing the project, ready to present their qualifications. Since the design cost is only a tiny fraction of the building cost, it is pretty much irrelevant whether the design exists already or not - it can easily be commissioned. It's as if I said "I have designed the world's largest aircraft carrier! It will have dozens of high-tech fighters

and bombers, a crew of ten thousand, redundant nuclear reactors, and many other great features. Anyone want to build it?"

Now, I'm glad that there are people out there who are so excited about floating cities that they work on designs for fun. I want people to be excited and inspired, and I think that it's great that the idea of a floating city is so appealing. I'd love to see a 3D model of this guy's city, for inspirational purposes, a vision to work towards. But it is important not to get distracted and mistake such visions for progress. Progress is getting funding and building working prototypes, it's functioning business models (pirate radio stations), it's people starting a data haven on Sealand. Sure, pirate radio and Havenco both failed. But when floating cities happen, they will happen from a start like that, not from a thousand people drawing a thousand designs of a city that will never be.

11.2 Alexandisle

As of 2004, this was one of the most recent new country projects. Created by Kevin Alexander (hence the name), it is a haven for non-believers, where faith-based promotion is considered fraudulent. It has an unusual government structure: there are no taxes during an individuals lifetime, but upon death, no more than \$200,000 can be left to any one heir (excepting spouse(s)). The remainder must be given to charitable organizations which perform all social services normally administered by modern governments. Anyone can found a new charity if they are unsatisfied with current ones. The founder believes that this prohibition on inheritance will appeal to independent, self-made individuals.

While we have serious doubts about the appeal and viability of this system, the strength of the small-nation approach is that people can experiment with many ideas and see which work. Thus we wish them the best of luck. Additionally, Mr. Alexander is writing an upcoming book *Ten Thousand Nations*, which suggests *"that humanity is much better off with lots of small governments, rather than a few large ones"*[AlexanderUnp]. As we wholeheartedly agree with this idea, we look forward to this contribution to the tiny niche of nation-founding books.

As of 2008, little had been heard about this project for several years. It appears to have gone the way of most such projects: a burst of initial enthusiasm which fades as the enormous difficulty of such an undertaking is realized. It is our job as seastealers to lower those costs and create a framework in which groups can more easily organize around shared visions of a better society.

11.3 The Pelagic Project

*Pelagic: Adj. Free swimming,
living in open ocean.*

While Wavyhill's time limitations have restricted this to a small (but informative) website [Pelagic] and a small scale model, we are still quite impressed with what we've seen. His philosophy is extremely realistic:

"This is a geopolitical experiment on life in a floating oceanic habitat with no mandated societal structure beyond that of a loose, employee owned and operated enterprise. ... Many of these projects have been initiated by idealists, with no

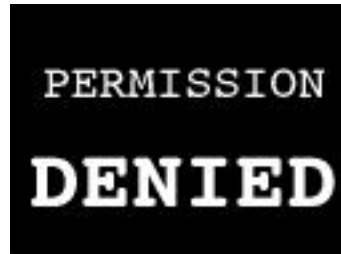

or vague business plan, expecting the rest of the idealists to rally to the cause and donate the required capital and effort. The pelagic project is not a utopian scheme, they never work. It's based on profitable enterprise, gradual growth, and being prepared for the worst from people and political organizations

He has a well-thought out timeline based on an incremental approach, and discusses the problems of building, operating, and financing such a project. The basic structure is a large (50ft) ferrocement hexagon, divided into small interior hexagons using cellular concrete. We discuss this lightweight concrete in the design section. Since it floats on the surface, his structure is exposed to wave action, and without a breakwater we don't think it would be suitable for the open ocean.

In 2003, Wavyhill actually made a 1/12th scale model of his design using a cheap home-built foammaker. This may not sound like much, but experimentation and a willingness to start with small prototypes is rare among nation-founders. This is unfortunate since we think it's crucial to success. While this project is no longer active, we definitely recommend checking it out to see someone else's version of the incremental, realistic sort of approach which we are convinced is the most promising.

11.4 New Utopia

The New Utopia project is a proposal to build a new country on an unused sea mount in the Carribean. Like the Freedom Ship, this project has been able to garner a significant amount of press coverage, especially at the beginning when it seemed viable. Former insiders report that there was significant business interest. Unfortunately, the leadership was not interested in tackling the hard problems that came up, preferring to sell a fantasy. Given what happened with Minerva Reef, we are very doubtful that any sea mount raised above surface level will remain unclaimed by the existing sovereign nations for very long. More importantly, a number of more recent reports have suggested that the project has become little more than a scam [Patri_NU].

11.5 The Venus Project

Floating Cities are one part of Jacques Fresco's The Venus Project [VenusProject], which aims to redesign world civilization to be more in line with human and environmental concerns. This includes switching to a resource-based world economy. While we are a bit suspicious of their economic theories, Mr. Fresco has quite an impressive resume. He's also designed and built a research center for the project, which puts it well ahead of the plethora of similar-

sounding visions. Unfortunately, they said we could not use any pictures from their site in this entry because our description was too negative, which is a bad sign.

11.6 Spar Buoy

The Spar Buoy concept [Piolenc2001] is the brain child of F. Marc De Piolenc. The concept is to build a livable structure that is basically a long cylinder that is ballasted on one end to cause the cylinder (i.e. spar) to float vertically. Since the center of gravity is significantly below the center of buoyancy, it is basically impossible to tip the structure over. In severe ocean storms, the cylinder bobs up and down with the waves and the cylinder occupants may get quite motion sick, but they should survive.

11.7 Ballard's Ocean Watch Tower

More recently, Dr. Robert D. Ballard (of finding the Titanic fame) has proposed building a modest ocean habitat that has many similarities to F. Marc De Piolenc's spar buoy idea. The idea is to start with a ballasted spar and then place a somewhat larger habitat on top. Thus, the difference is that the living quarters are on top of the spar rather than on the inside of the spar. This proposal has the advantage of being quite modest and Dr. Ballard's obvious oceanographic experience would provide a great deal of credence to any investors.

11.8 Reed Ship

Enrique Perez has come up with a novel idea based on ancient reed ships [Perez2001]. The basic idea is to make the whole flotation system flexible enough that it just bends and sways in severe ocean storms. He has come up with scripts that allow you to compute the costs and buoyancies.

11.9 Atlantis Project

Another project out there for awhile was the Atlantis project. This project has an above average number of pretty pictures, created by architect Jim Albea [ShadowMasons]. Indeed, it was this site that got Wayne Gramlich interested in the concept of seasteading.

11.10 Seascape

Many nation-founding projects and websites focus on pictures instead of planning. The Seascape site takes this to an extreme, as it consists almost entirely of pretty 3D rendered pictures and animations (along with a little flavortext). The result is to showcase artistic skills rather than present a practical proposal. As reader Glen Raphael comments:

They never quite make it clear why having drink-dispensing robots following guests around the complex is an improvement over the usual alternatives. Sure, it could be cool in a sci-fi sort of way, but it's ludicrously inefficient. Wouldn't some combination of drink vending machines, water fountains and human waitpersons delivering your drink order to human bartenders work just about as well and be a lot cheaper, more energy efficient, and more reliable? ... One really does

get the sense this is more about creating an interesting science-fictiony fantasy environment than it is about making something practical. .

When asked for permission to use a picture with the text above, the project authors commented:

.The site you saw is only an inter-office overview. Seascape endeavors to provide an environment that is responsive to the individual- it makes no attempt to be practical (or impractical for that matter). Does your city know you? Is your city "interactive"? We urge you to "stay tuned" over the ensuing months to see if we distinguish ourselves. Good luck on your compendium of sea-faring environments. You may wish to re-read the "flavor-text". .

Unsuprisingly, their website has not changed in the ensuing years. While there is nothing wrong with this approach per se, it makes it harder for those of us interested in the reality of floating cities to get taken seriously.

11.11 Triton City

Buckminster Fuller designed a tetrahedral floating city for Tokyo bay in the 1960's. He wrote:

Three-quarters of our planet Earth is covered with water, most of which may float organic cities...Floating cities pay no rent to landlords. They are situated on the water, which they desalinate and recirculate in many useful and nonpolluting ways. They are ships with all an ocean ship's technical autonomy, but they are also ships that will always be anchored. They don't have to go anywhere. Their shape and its human-life accommodations are not compromised, as must be the shape of the living quarters of ships whose hull shapes are constructed so that they may slip, fishlike, at high speed through the water and high seas with maximum economy...Floating cities are designed with the most buoyantly stable conformation of deep-sea bell-buoys. Their omni-surface-terraced, slop-faced, tetrahedral structuring is employed to avoid the lethal threat of precipitous falls by humans from vertically sheer high-rising buildings...The tetrahedron has the most surface with the least volume of all polyhedra. As such, it provides the most possible 'outside' living. Its sloping external surface is adequate for all its occupants to enjoy their own private, outside, tiered-terracing, garden homes. These are most economically serviced from the common, omni-nearest-possible center of volume of all polyhedra...When suitable, the floating cities are equipped with 'alongside' or interiorly lagooned marinas for the safe mooring of the sail- and powerboats of the floating-city occupants. When moored in protected waters, the floating cities may be connected to the land by bridgeways.

[Banham1976]

There are some similarities between Bucky's design for a floating city and our current plan. Both have buoyancy was located below the wave action, and both use slopes to give residents more solar area.



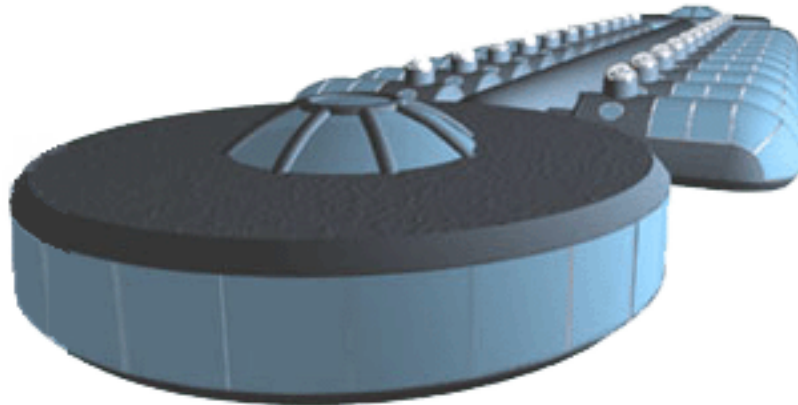

11.12 Ocean Base One

The Ocean Technology Foundation has proposed an undersea habitat called Ocean Base One as part of its OASIS research project [OASIS]. 3D images of the design have been featured on Tech TV and The Learning Channel, as well as in several print media outlets. Its main purpose is research, and it is to be funded by foundations, oil companies, the government, and other sources [Behar2002]. They expect to complete funding and begin construction in approx. 2007-2010 [Rappaport2002]. While such claims should be treated with some skepticism, there are a number of points in its favor. OTF is an established foundation, oil companies and government departments have lots of money, and the \$75M budget is modest compared to gargantuan proposals like the Freedom Ship.

11.13 Poseidon Undersea Resort

This project has been proposed by US Submarines, which has succeeded in getting a fair amount of media attention for its personal and tourist submarines. For example, a \$20M model was listed in one of Neiman-Marcus's christmas catalogues. Poseidon is their concept of an undersea resort containing a restaurant, bar, kitchen, foyer, and 20 luxury suites. It would be in 30-60 feet of water, and locations being considered include the Bahamas, United Arab Emirates, and Belize. The interior pressure would be maintained at one atmosphere.

Here is an update as of March 2009, from email correspondence with Michael Schutte, CEO of Brilliant Boats LLC:

The Poseidon project has been stalled for about 6 months due to short-term financing issues related to the financial crisis. It looks like they will be back in business in a few months on this one. The design and engineering is 95% done with a few parts to be reanalyzed in FEA to finalize the construction model. Brilliant Boats was responsible for the design and engineering, as well as interior layouts and systems.

We are now working a semisubmersed offshore platform that will be sited in a national water park in Oman, and an underwater house for a client in Belize.

There is definitely a lot of interest out there for this sector - I have just come back from the Dubai and Abu Dhabi boat shows where we were completely swamped by the media and interested parties. It seems that this idea has finally come of age. The truth is that with the budgets people have to buy toys these days, what we are proposing is just not that expensive anymore. We have recently finished a 60m yacht for which the budget was over 40 million US, and this was a bargain. There are boats in build today that will cost ten times that, and these are toys for individuals.

Chapter 12

Historical Hacks

While political sovereignty is our interest, many past projects have taken advantage of the ocean's freedom in other ways. They demonstrate that "hacking the system" really can work. It's important to have this empirical evidence to show that there our ideas are not just based on theory. Many political movements have failed because they misunderstood the difference between theory and practice, words and actions, vision and reality.

{ If you have any similar examples of using international waters to increase freedom, please let us know }

12.1 Gambling Ships

Anyone who has been on a cruise ship knows that gambling in international waters continues to the present day. Its history near the United States, however, is a bit rocky:

Earl Warren...decided to advance his career by declaring war on the gambling interests. The operators responded by moving the casinos onto ships keeping the old mother-ship stations off the coast. The first reaction of Warren was just to go out and break up the casinos anyway, never mind that his lawful authority ended at the territorial limit. This is yet another caution to new-country organizers not to place overmuch faith in the written law.

However, the operators then went into Federal court...Roosevelt's Democratic Federal Regime wasn't very interested in helping him with his crackdown...when World War II broke out. The "war emergency" and ensuing near-panic on the West Coast were used as an excuse to shut down the ships summarily. After the war, a Federal law was finally passed making it illegal for a United States citizen or resident to own a gambling ship, or for anyone to transport people between the United States and a gambling ship...such a ban could likely be defeated on a challenge. But then other measures to harass the ship doubtless would be taken. In any case, with the spread of legalized casinos onshore, the long-term prospects for casino ships appear limited.

[Strauss1984, p. 140]

Despite this pessimistic outlook, gambling cruises are still an active business. For example, a 2002 article on gambling in the southern US reports: "FLORIDA: Numerous gambling cruise vessels, ranging from ships carrying 1,800 passengers to yacht-size boats carrying 150, sail from the East and West coasts into international waters where gambling is permitted.

The boats offer roulette, blackjack, craps, video poker and slots, with some of the larger cruise ships offering additional games.” [McBee2002]

12.2 Pirate Radio Boats/Platforms

The offshore pirate radio movement is interesting both for its own sake and in relation to the ideas of seasteading. A summary appears in Strauss:

In the 1960’s, a new form of offshore activity emerged. Commercial radio as known in the United States didn’t exist in Europe at the time. With few exceptions, all that was to be heard were staid government stations. Then a ship named *Veronica* dropped anchor just off the Dutch coast, with a transmitter beaming programming filled with the latest popular music. Advertisers eagerly bought up all the available time at premium rates, and imitators soon followed in the Scandinavian and British markets...At first, there was considerable violence between ships; however, the practice of maintaining 24-hour watches soon reduced that greatly...

The governments of Europe were outraged, and applied the pejorative term ”pirates” to the broadcasters, a term with which they weren’t entirely unhappy - due to its romantic connotations. Attempts were made to jam the ships’ transmissions, but the public outcry was too great...International agreements were entered into to ban broadcasting from ships, but the African country of Sierra Leone chose to offer its flag as a flag of convenience rather than subscribe to the treaties...

The British finally knocked their offshore broadcasters off the air by banning advertising on them by firms doing business in the United Kingdom...then the coup de grace was delivered: the opening of popular music stations on land.

[Strauss1984, p. 141-145]

Various snippets from another chronicle of pirate radio’s colorful history help fill in more detail:

”badly needed a way to break the ’payola’ monopoly enjoyed by the ’big four’ recording companies Decca, Philips, EMI and Pye.”

”Only three weeks after it started the pirate station had an estimated 7 million listeners ”

”Tragedy occurred at Red Sands fort on December 16th when RADIO INVICTA co-owner Tom Pepper, engineer Martin Shaw and disc jockey Simon Ashley were drowned in very bad circumstances following the capsizing of their launch after having delivered supplies to the station ”

”The start of 1965 saw some ’big guns’ lining up against the pop pirates when, on January 22nd, the governments of Belgium, France, Greece, Sweden, Luxembourg, Denmark and Britain signed a Council of Europe Agreement that not only banned broadcasts ’on board ships, aircraft or any other floating or airborne objects’ but also banned anyone from those countries from supplying the pirates with materials, supplies or equipment. The stations were forced to obtain new sources of supply from either Holland or Spain, neither of whom had been party to the agreement...Caroline’ was also in the happier position of being able to obtain supplies from Dublin or even the Isle of Man as the Manx

government were reluctant to ratify legislation against the pirate ship due to the trade and tourism she brought to the island. ”

”On May 12th at 5p.m. the entire Beatles ’Sergeant Pepper’ was played by Radio London, two weeks before its official release date, despite the fact that no promotional versions had been issued by EMI. The origin of the music has never been explained, although Paul McCartney’s house had been burgled a fortnight earlier and among the items taken were two proof pressings of the disc....”

”At midnight on 14th August 1967, The Marine etc, Broadcasting (Offences) Act came into force, which effectively banned all U.K. subjects from being involved with offshore broadcasting within territorial waters and rendering all the pirate radio station operators and personnel open to prosecution as soon as they came within the ’3 mile limit’...RADIO VERONICA, being off the Dutch coast, was unaffected by the British Act but had its own problems in the Seventies when the Dutch government finally got around to passing a similar law...The last of the legendary Sixties offshore pirates still operating in its original form, RADIO VERONICA, finally succumbed to the Dutch Marine Broadcasting Act on August 31st 1974. ”

[SixtiesCityPR]

The history of pirate radio is fascinating and involved. While we’ve only briefly touched on it here, you’ve heard enough about pirate radio and gambling ships to see a common life cycle for such ventures. Government regulation creates a market. An offshore provider springs up to serve that market, and at first enjoys tremendous success. New regulations attempt to limit the industry, with mixed success. Finally, the onshore industry opens up - not as open as the pirates, but with a small enough difference that the extra costs and difficulties of offshore operation render the pirates uncompetitive.

We’d like to point out that if the offshore provider’s goal was to stay in business and make money forever, being co-opted like this indicates failure. But if the goal was a social movement like increasing freedom, it is at least partial success. We’d consider it a victory if building seasteams becomes unattractive because traditional governments become more dynamic and flexible. However, we think this is unlikely because of some key advantages of water over land which we’ll talk about in the next section.

Although pirate radio history is definitely relevant, there are some important differences between pirate radio and seasteading. First, note that these broadcasts targeted sovereign territory, infringing the government’s right to control the signals on its land. This is a much more questionable activity than seasteading, and more likely to generate a strong reaction. Also, the government cracked down by making it illegal to advertise on pirate radio ships or sell them supplies. Advertising doesn’t work unless you know what the product is, thus it’s easy to crack down on. Also pirate radio ships were not in the least self-sufficient. So stronger economic levers were available against this business than will be for opponents of seasteading.

12.3 Havenco

This was an internet server business run on Sealand, offering secure colocation facilities without government regulation. While it’s not clear exactly why the business failed, there are a number of strong possibilities.

In the beginning, they got a fair amount of publicity as a ”data haven”. However, they had to compete with small countries around the world also eager to profit from a low-regulation

environment. They were founded just in time for the dot-com crash and associated global recession. A few years later, when the War on Terrorism got going, the owners of Sealand become worried about anti-terrorist blowback. Furthermore, as a somewhat amateur venture, Havenco was plagued with business problems, at least according to cofounder Ryan Lacky, who spoke at Defcon about the experience [Defcon.Havenco].

From his report, most of the time was spent dealing with the large amount of press stemming from a Wired magazine cover article, rather than on sales and customer service. The business was disorganized, lacking proper capital, and displaying a much better face to the world than the actual situation. Eventually, the business problems, and the issues between Sealand and Havenco led to the end of the company.

Many of these are important points for prospective seastealers. If they are building a business, not just a home, it needs to be run like a business - which means a reasonable amount of financing and business experience for the job at hand. The difficulties in being reliant on the whims of Sealand's owners is an example of why it is better to find solutions that don't depend on a cooperative host country. And on a more optimistic note, HavenCo found it quite easy to get a huge amount of publicity, which would have been invaluable if they'd had the other pieces in place.

The reason we include the business here, rather than among failed projects, is that nowhere in that list of reasons is "significant interference from other states". Havenco successfully hosted online gambling sites through an internet connection to the UK, less than 10 miles away, which would not have been legal in that country. They were left alone, and not because they had a navy to match the UK's (an amusingly laughable fantasy), or because no one had heard of them (quite to the contrary!). Instead they just chose a business they could get away with and a location with reasonable historical precedents to be independent.

12.4 Women On Waves

Whether or not one agrees with their views, the pro-choice Dutch project [Women On Waves](http://www.womenonwaves.org/index_eng.html) is a good example of the potential for using international waters for political freedom. One of the founders of WoW had been a doctor on board the Greenpeace vessel *Rainbow Warrior*, and was influenced by offshore pirate radio. They traveled to Ireland in 2001 and Poland in 2003. In their own words:

Women on Waves is a non-profit organization concerned with women's human rights. Its mission is to prevent unwanted pregnancy and unsafe abortions throughout the world.

Every year 20 million abortions are performed under illegal and unsafe conditions, resulting in the deaths of an estimated 70,000 women annually. In response to this medical calamity, Women on Waves has developed a mobile gynecological unit, the 'A-portable'. It can easily be loaded onto a ship, which enables it to travel to wherever it is needed worldwide. The 'A-Portable' can also travel by truck allowing it to go to countries where reproductive health services are legal but largely unavailable, for example due to war.

With a ship Women on Waves can provide contraceptives, information, training, workshops, and safe and legal abortion outside territorial waters in countries where abortion is illegal. Working in close cooperation with local organizations, Women on Waves wants to respond to an urgent medical need, empower women to exercise their human right to reproductive health and legal, safe abortion and

draw public attention to the consequences of unwanted pregnancy and illegal abortion.

An Australian doctor proposed a similar plan in 2000 and 2001 for a "euthanasia ship" to legally help end the lives of terminally ill patients [Batty2001]. However nothing further appears to have been done.

Part IV

Ocean Environment

Chapter 13

Ocean Introduction

_ The ocean is a wilderness reaching round the globe, wilder than a Bengal jungle, and fuller of monsters, washing the very wharves of our cities and the gardens of our sea-side residences. Serpents, bears, hyenas, tigers rapidly vanish as civilization advances, but the most populous and civilized city cannot scare a shark far from its wharves. [Thoreau1906, vol. 4, p.188] - { Does this seem like a good introductory ocean quote? Any other suggestions? }

A seasteed needs to survive and thrive in the ocean environment. In this section we'll describe that environment, its dangers, and our plans for avoiding them..

What is the ocean environment? Obviously, it consists of a great deal of salt water (about 3% solution.) The dissolved salt causes two problems - first, it causes many materials to corrode and second, it renders the water unfit for drinking. In addition to the water, the ocean environment has weather. This includes temperature variation, wind, humidity, rain, etc. Convection and Coriolis effects cause movement of the air (wind) and water (currents) in roughly consistent patterns. The wind causes the growth of waves which can become quite significant.

The ocean is full of life, from tiny algae to the largest living creature: *Balaenoptera musculus* -, *the blue whale*. *The most dangerous marine creature, however, is homo sapiens*, whose warships have teeth sharper than any shark. Correspondingly, the most complicated element of the ocean environment is the labyrinthine system of laws and regulations that humans have developed to govern it.



Chapter 14

Waves

14.1 Ocean Wave Basics

The high point of an ocean wave is called the crest, and the low point is the trough. The distance from crest to trough is of course the wave height, and the distance between successive crests is known as the wavelength. Waves are created by wind blowing on the oceans surface, which steadily adds energy to them. The size of waves thus depends on how hard and for how long the wind blows. Because waves can travel long distances without losing much energy, they may appear when there is no wind, having been produced by some distant storm.

While it may appear that waves consist of water moving linearly, in reality each water particle simply travels in a circle. The water transmits energy without being carried along. This is why small free-floating objects on the surface just bob up and down in waves. Even in huge waves, a piece of driftwood doesn't get broken, just shaken around a lot.

However, our potential seastead designs are not like this. Objects that are large or heavy don't just roll with the waves, they resist and must absorb some energy. For them, the ocean is a much more hostile environment. The amount of energy stored in a large wave is quite scary, hence why they occasionally pulverize large ships. You'll first learn about the biggest waves, and then about our strategies for avoiding them.



14.2 Tsunamis

Many people think of the tsunami as the most fearsome wave, but that's a landlubber's perspective. Generally driven by earthquakes, tsunamis are often unnoticeable in the deep ocean, where they have extremely long wavelengths and low wave heights (several meters at most, usually much less).

As this wave reaches a continental shelf, it piles up, becoming shorter and higher. Only then will it resemble the monsters of legend - and as usual, legend exaggerates. Tsunamis rarely result in giant breaking waves, but are more like very strong, fast tides [USGST-sunami]. While this is very dangerous for coastal structures (as the horror of the 2004 Asian tsunami demonstrated), even if a seastead was close to shore, it would just rise with the water level. The worst consequence would be the mooring system failing or being damaged.

Now we'll see a case where the storytellers, not the scientists, turned out to be right.

14.3 Rogue Waves

They were struck by a rogue wave - a monstrous wall of water that rose out of nowhere and slammed onto the deck like the fist of god. Ships often don't survive an onslaught like that. Many sink before anyone on board knows what's hit them.[Lawton2001]

On the right is perhaps the only photograph of an elusive phenomenon known as a rogue wave. Not many people would reach for a camera when struck by such a monster, but that's exactly what Phillipe Lijour did. He was onboard the oil freighter *Esso Languedoc* in 1980 when it was struck by a rogue. By his estimate, most waves were 5-10m, as you tell from the low seas in the background. The mast visible on the starboard side is 25m above sea level, and the wave is breaking from behind the ship. The wave was at least 20m high, perhaps 30m (since its trough, as well as crest, would be lower than other waves).

Scientists used to dismiss such tales of unusually large waves as mere folklore, like monsters or mermaids. But with the proliferation of oil and gas platforms, some of which record wave data, accumulated observations have finally led to mainstream acceptance of this seafaring "myth" [Lawton2001]. And recent data from the European Space Agency's ERS satellites has not only re-confirmed the existence of these waves, but indicated that they may be fairly common. Researchers with the MaxWave project computer-analyzed satellite photos from a three-week period in 2001 during which two ships were hit by 30m rogues. They found "*ten individual giant waves around the globe above 25 metres in height.*"[ESA2004].

These rogue waves are the real dangers in open water. Towering above their neighbors, they are unstable and break quickly, thus containing tremendous power. They sometimes come unexpectedly from a different direction than the prevailing swell, which adds to the surprise and danger. Rogues have been known to ravage coastlines as well, sometimes coming out of calm seas to sweep away unsuspecting victims. Emergency services have warned beachgoers in some areas to be aware of this danger [RogueWarning].

Understanding rogue waves is clearly quite important for marine safety. Hence while their existence has only been accepted for a few decades, a decent-sized body of academic work has sprung up. There was a Rogue Wave conference in 2000 [RogueWaves2000]. Theories about their existence include interference patterns (refraction/diffraction), current/wind interactions, and normal variations in the height of wave groups. These theories are problematic, however. Interference ought to produce a bell-shaped distribution, but high outliers occur

much more often than that. Also, in the open ocean it is unclear what would cause an interference pattern. Current interactions don't explain the many rogue waves in areas without fast-flowing currents. Focusing effects of some type seem to be the most promising. They are difficult to analyze on messy real-life waves, but some non-linear mathematical models have produced focusing and shown promise at replicating the observed distribution [NorwayRogueGroup]. And the MaxWave team is starting a new investigation called WaveAtlas to further study the distribution of rogue waves.

The question of how big waves get and how often they hit is of far more than academic importance. Most offshore platforms and cargo ships have been designed assuming the standard distribution. This is why rogue waves are so dangerous - not just because they are big, but because they are **unexpectedly** big, and so structures are not designed to handle them. We can see that a seastead intended to last decades must be prepared to withstand these "Monsters of the Deep".

14.4 Wave Height

To design a safe and reasonably-priced seastead, we need to know what wave heights to expect. Most important is the worst-case height. Since this will depend on the exact region and seasons, we'll just give a general overview, as well as sources for additional information. Wave height is a function of wind strength and the "fetch", which is the distance over which the wave been building. Oceanographers use a statistic for wave height called the "significant height", denoted H_s . This is the average of the 1/3 highest waves (from crest to trough) over a given time period (20 minutes for [NDBC] buoys). One wave in a thousand is twice H_s , and about one wave in three-hundred thousand is a so-called "rogue" whose height is two and a half to three times H_s [Bascom1980]. However, this distribution may reflect out-dated assumptions about rogue rarity, and must be investigated further.

The National Data Buoy Center [NDBC], part of the NOAA, is a good source for wave height information. Data from several hundred buoys (not all theirs) is accessible on their website, often with historical records. The highest waves ever recorded by the NDBC buoys were in the North Pacific, near the Aleutian Islands, and had an H_s of 18m. A rogue wave in that storm could have reached a staggering 48m in height. The location is no accident. While 100-foot waves in the North Atlantic are rare enough that it took a "Perfect Storm" to create them, David Gilhousen, a meteorologist with the NDBC, says that in the North Pacific "sea waves of that magnitude are something you would see every other year - maybe every year" [Chui2000]. Not the best place to build a seastead.

The highest wave ever accurately assessed at sea was seen from the USS Ramapo on February 6, 1933, and measured at 34m by triangulating on the crow's nest. The ship was on passage from the Philippines to California during a hurricane with a wind force measured at 68 knots. The storm lasted 7 days and stretched from Asia to New York, producing strong winds over thousands of miles of unobstructed ocean. Other sources have reported rogue waves of 17.5m (Skourop, North Sea), 26m (1/1/95, North Sea), 28m (1943, North Atlantic, the Queen Elizabeth), and 29m (1995, North Atlantic, the Queen Elizabeth 2) [Lawton2001].

It not only takes strong winds to generate these monster waves, it also takes a long fetch. For this reason, sheltered seas like the Mediterranean and the Caribbean experience smaller waves even during severe storms. The doldrums around the equator, where winds are low, are another area with much smaller waves. Cautious seasteaders may wish to gain some experience in these places before venturing into rougher areas.



14.5 Calamity

"One thing about the sea. Men will get tired, metal will get tired, anything will get tired before the sea gets tired" - A marine engineer's observation about the tragic collapse of TT-4.

The loss of Texas Tower Four demonstrates the disasters that can occur when a flawed structure encounters the tremendous power of the ocean. The tower was one of three manned radar platforms off the US Atlantic coast numbered Two, Three, and Four (One and Five were planned but never built). The tower, part of the nation's air defense system, "was such a spectacular sight that ocean liners veered off course to permit passengers to glimpse it" [TexasTowersRD, p. 95]. Because it was a lonely post, the interior of each tower had libraries, gyms, and rec rooms. Music, movies, and even a daily ration of beer helped entertain the crew.

Things began to go wrong with Four from the beginning. Built in a Portland, Maine shipyard, it was completed in June of 1957. While a convoy was towing it to its permanent location, a sudden storm struck and damaged the tower. (For those with an engineering bent, it tore off the diagonal cross braces on the legs). Because of the cost and time delays involved in towing it back for repair, the tower was installed anyway (the civilian contractor said that the damage could be repaired on-scene). This problem was especially serious because TT-4 had legs more than twice as long as the other towers and needed these missing supports. Divers later installed an extra piece to compensate, but it proved insufficient for the task. Even modest waves caused the structure to tremble (earning it the nickname "Old Shaky"), and over time the bracing was compromised. Again, divers attempted to repair it, but in September of 1960, Hurricane Donna destroyed the patchwork repairs with 132mph winds and 50-foot waves [Ray1965].

The towers lurching worsened and most of those onboard were evacuated, but a skeleton crew remained. They were there to protect the millions of dollars in radar equipment from the Russians, and to maintain the tower while more repairs were attempted. In January of 1961 there were 28 crew, half of them USAF personnel and half a civilian repair team. Warned by radio of an approaching storm, the next cargo ship offered to evacuate the tower, but orders from land said for the men to stay on the tower and the ship to stand by. The chain of command for the towers was poorly designed, and apparently the superior officer on land was unsure of his authority to evacuate the station.

The storm arrived, and while it battered the waiting cargo ship and the shaking tower with 85mph winds and 35-foot waves, the commander on shore finally decided to evacuate during the next lull. Helicopters from the Coast Guard waited to take off the moment the weather permitted, and the Towers crew frantically cleared off the flight deck. But the weather refused to slacken, and under the incredulous eyes of the cargo ship captain, the radar image of Texas Tower Four disappeared from his screen. All hands were lost. [TexasTowersRD]

It was later determined that one of the three legs had broken under the strain, rendering the tripod of support unstable. it's important to note that Towers Two and Three survived this and many other Atlantic storms over the next few years, although they were evacuated a number of times to ensure that no repeat tragedy occurred. Eventually currents weakened the foundations and they were decommissioned. (We'd like to note here that the TT's weakness was their supporting legs, which our design avoids entirely).

The lesson is not that permanent manned sea structures are impossibly dangerous, but that the ocean does not forgive mistakes. Great care must be taken in the design and building of seasteads to ensure their absence from the annals of marine tragedy. This will increase their expense, but safety - a matter of life and death - is no place for shortcuts.

14.6 Avoiding Waves

Because waves are so dangerous, we think it's quite important to be able to avoid or nullify them. Our preferred design, the spar platform, handles this by lofting the living space above the waves on a tall pillar. While this keeps a seastead from being pummelled by the waves around it, it may also want to avoid big waves in the first place. Since a seasteads only place in the America's Cup race would be as a buoy, this requires planning well in advance. There are other methods for minimizing this danger as well. Here are the techniques we consider:

- Build a pillar platform or spar platform, with a sufficiently long spar that waves don't hit the platform.
- Use natural or artificial breakwaters to protect structures from the waves.
- Build underwater structures.
- Choose an anchorage or roaming area without large waves, like the equatorial doldrums or a protected sea. Or, since storms tend to be seasonal, stay in these locations during the dangerous seasons.
- Actively avoid storms by moving around. Small waves grow into large waves slowly, so thanks to meteorological satellites and computer prediction, it is reasonable to expect around 5 days of advance notice in which to avoid bad waves [Chui2000]. This gives enough time for a sailboat fleet to run away, although not a lumbering platform.

Chapter 15

Wind

Pleasant it is, when winds disturb the surface of the vast sea, to watch from land another's mighty struggle. Lucretius

As anyone who has been in a sailboat or forgotten their jacket can tell you, air may be thin but it can still transfer a lot of energy. Because wind will move seasteeds around, batter them during storms, and help them generate electricity, it is an important part of our ocean environment. There are basically two kinds of winds we need to worry about, the good kind which blow slowly and steadily, and the bad kind which swoop in occasionally and try to steal anything which isn't nailed down.

15.1 General Circulation

As with currents, global forces cause wind to have consistent, large-scale patterns. The equator receives more heat, so the air above it is warm and rises. As a response, the surface air nearby (± 30 (deg) lat.) is drawn towards the equator to replace the risen air. Together, these form a classic convection cell. At the equator itself, since the air is rising



(and new air coming in from both sides), there are no steady surface winds - the wind is vertical instead of horizontal. Since vertical wind doesn't generate waves, this area enjoys calm weather and is called the doldrums.

Farther from the equator in both hemispheres (30-60 (deg) lat.), the Coriolis Effect dominates, making the winds blow from west to east relative to the earth's surface. Above the poles, the air cools and sinks, forming another pair of convection cells.

These steady winds will be quite useful for energy generation, as described in further detail in the Wind Power section, which also contains a map of worldwide wind resources. Their consistency makes them an excellent energy source, since storing energy is relatively expensive. Unlike solar energy, which arrives for half of the day at best, the trade winds blow around the clock. Wind speed and energy grow significantly with height (this is why wind turbines are on tall poles), and seasteads are already high up to avoid the waves. Though they may necessitate a sweatshirt when going on deck, the trade winds are our friends.

One downside of the constant winds is the salt spray they carry. This can result in salt accumulation on surfaces, which is undesirable for gardens, trees, and farm animals.

15.2 Ill Winds

{ This subsection is new and quite rough }

Tropical storms, cyclones, and hurricanes have strong winds that can destroy conventional buildings, as well as triggering strange dream sequences that go eerily well with Pink Floyd albums. Luckily, even a Category 5 hurricane will have trouble lifting concrete off to the Land of Oz. For instance, a concrete Monolithic Dome called the Eye of the Storm was built on an island in south Carolina to replace a home lost to Hurricane Hugo in 1989 [MDI]. It and other domes were in the news after the relentless hurricane season of 2004 [MDI.Ivan], which they weathered without a blink.

Hurricanes are rated according to the Saffir-Simpson Scale:

Category Wind Speed Examples

1 74 - 95 mph (65 - 82 kts) Hurricane Irene, 1999

2 96 - 110 mph (83 - 95 kts) Hurricane Bonnie, 1998

3 111 - 130 mph (96 - 113 kts) Hurricane Fran, 1996

4 131 - 155 mph (114 - 135 kts) Hurricane Andrew, 1992

5 More than 155 mph (more than 135 kts) Hurricane Hugo, 1989, Camille, 1969

Storms of all sizes come with advance warning nowadays, thanks to the global network of weather satellites. Clouds are easy enough to see from space, and clever image processing even allows for estimates of wind and waves. As an article about the infamous "Perfect Storm" states:

Back then, he said, forecasters had to rely on scattered readings from buoys or ship crews to gauge the state of the wind and seas. And the computer graphics that help them quickly grasp and interpret weather data were not as advanced...In the nine years since the Andrea Gail went down, computer models have improved to the point where forecasters can give people at sea five days' warning of severe wind and waves, compared with two days in 1991, said Joe Sienkiewicz, a senior forecaster with the National Weather Service's Marine Prediction Center in Camp Springs, Md. Satellites now sweep their radar and microwave eyes over the ocean surface, taking in swaths 930 miles wide, and beam back information on wind speed and direction.

Figure 15.1:

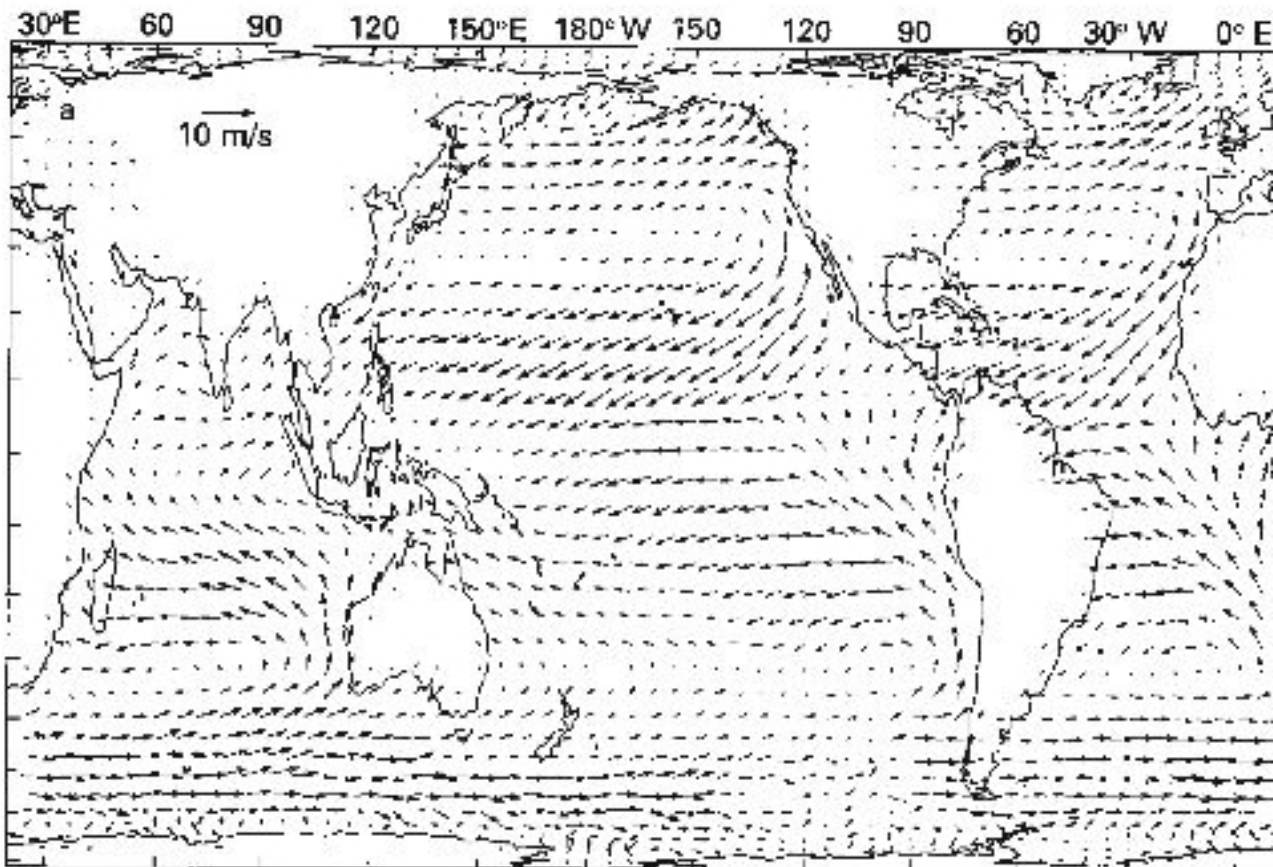

Surface winds over the World Ocean. Annual mean for the period 1950-1979.

[from Tomczak, M. and J. S. Godfrey (1994), Regional Oceanography: An Introduction, Pergamon, Fig. 1.2.]



While the exact occurrence and course of any storm are unpredictable, the general trend is quite consistent. There is a "hurricane season" in late summer and fall (which are opposite months in the Northern and Southern hemispheres). Storms usually move westward and at less than 20mph, so there is plenty of advance warning (although course tracking is imperfect). The most dangerous part of a storm is the quadrant where the rotational and translational velocities add. As with the trade winds, speeds increase as you rise above sea level, which means that seastead platforms will be subject to some pretty strong forces. Because of its shape, the upper part of a seastead will act like a wing, and its design must take into account these aerodynamic characteristics.

While winds will be stronger blowing unobstructed over the oceans, a major advantage is that they will carry very little debris. Even at 150 mph, wind is much easier to withstand than tree branches. A University of Missouri-Rolla study confirmed this, saying "We concluded that the majority of damage didn't come from high wind pressures as many building designers originally thought, but from windborne debris impacts." [Kaiser2000]. Other experiments have confirmed this:

Evidence from an experiment at Texas Tech University's Wind Engineering Research Center (Concrete Products, August 1998) seems to confirm the intuitively obvious: Of all commercial building materials, concrete provides the greatest resistance to extreme high winds and debris...The greatest inherent danger to people and property during the high winds of tornadoes and hurricanes is the debris carried in the high winds. Flying at such intense velocity, wreckage can cut right through a building wall and endanger the people inside. Tests conducted by Texas Tech University's Wind Engineering Research Center offer dramatic proof that concrete walls withstand flying debris from tornadoes and hurricanes-and outperform their wood and steel counterparts. To duplicate tornado-like conditions in the laboratory, researchers shot wall sections with 15-lb. 2 Yen 4 lumber "missiles" at up to 100 mph, simulating debris carried in a 250-mph wind. These conditions cover all but the most severe tornadoes.[ConcreteProducts1998]

Flooding, which erodes foundations and washes through lower stories, causes much of the damage on land. This "storm surge", happens because the pressure from a storm piles up the

water, increasing its level. However, it will have little effect on seasteads, which are already floating and will simply rise with the water (though there are some minor complications for anchoring [[link to engineering of anchoring](#)]). Listing (leaning to the side) due to wind forces is a not likely to be a major problem, even in high winds, as we explain in the relevant FAQ.

Given that most damage comes from storm surge and debris, it does not appear to us that hurricane winds are a major danger for seasteads. Waves are the real danger. When it comes to wind, the seastead should actually have an easier time than coastal residents. Some precautions will still be required.

Energy gathering may cease during a storm, with wind turbines taken down and PV panels ineffective. Generators will most likely take up the slack, although special turbines geared for higher velocities could be deployed during storms (perhaps a good time to test DIY Savonius rotors).

As with waves, seasteads will need to be built to withstand the worst winds they may encounter. While pictures of smashed homes fill our television screens after a hurricane, these structures are generally small and cheap. In the US, government backing of insurance companies is likely part of the explanation for this choice. In many places, it is due to poverty. As the Texas Towers tragedy taught us, seasteads must be built to last. Like the third little pig, we'll choose a material that can't be blown down.

Chapter 16

Currents

It is not only the oceans surface that is continually moving. Currents are everywhere as well, and unless we anchor they will push our platform around. Approaches to dealing with this are outlined in the Transportation section.

Currents tend to consist of large cyclical formations with opposite direction of rotation in the northern and southern hemispheres. They range in speed up to about 2.5 m/s. They are caused by a number of factors, such as wind, convection, density differences due to variations in salinity, and the Coriolis force. The chart below will give you a general feel for the arrangement of currents:

[Currently used **without** permission from a figure in Principles of Ocean Physics by John R. Apel, Academic Press, 1987].

However, it must be noted that these maps are deceptively simple. Ocean currents form many eddies and transient features, and vary from season to season and year to year.

Figure 16.1:

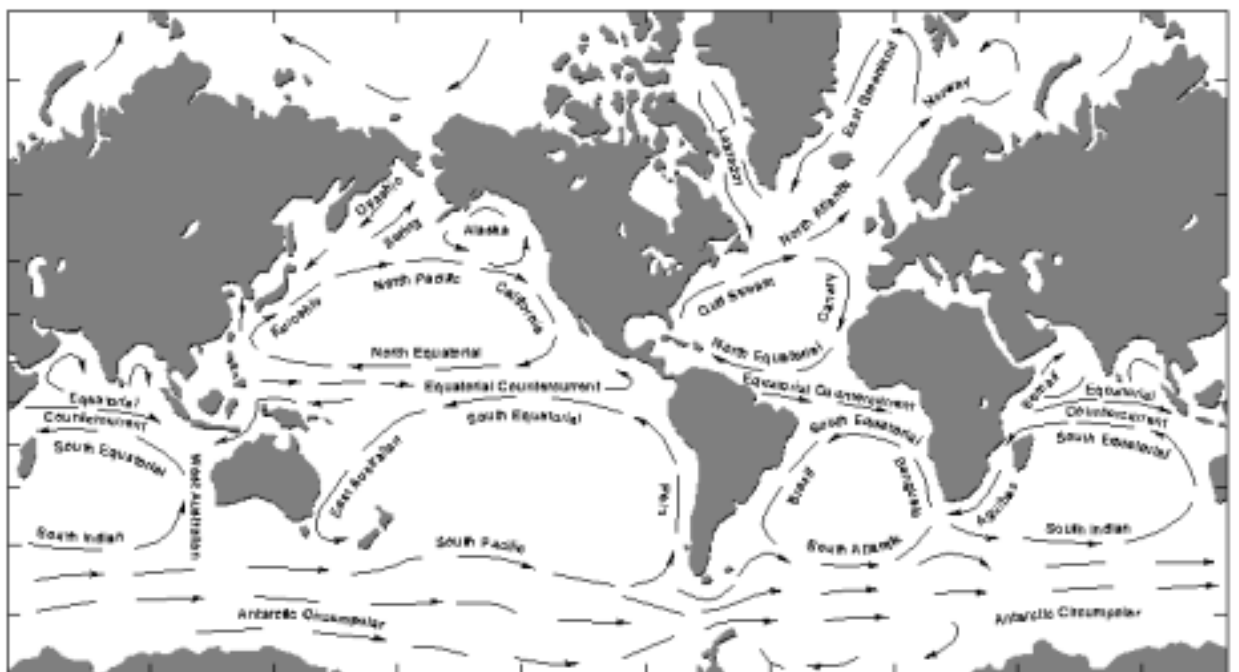

Chapter 17

Politics

{ Most of this section is new. Since politics is quite a complicated issue, its pretty rough too. Since there is so much to say, its a bit long and disorganized. We'd love to hear any clarifications from those with more than our scant knowledge of international maritime law }

17.1 Political Situation

Political Zones

The first thing to note is the separation of the ocean into several types of zones, each with different usage rights. Here are the basic categories:

Territorial Seas

Extending for 3-12 nm (usually 12), a country's Territorial Seas are an extension of its sovereignty over land. In fact, the 3nm original limit was chosen as the area which could be defended by cannonfire from land. While there are some exceptions (ie it is not allowed to block the passage of innocent ships), generally the country has complete jurisdiction.

Contiguous Zone

According to UNLOS Article 33, this is a zone contiguous to the territorial sea where the owner may exercise the control necessary to enforce its laws and regulations within the territory and territorial sea. For example, customs enforcement and drug interdiction are performed here. This creates similar problems to the territorial seas. Fortunately the total of territorial seas CZ may not extend more than 24 nm, at which point you might expect to be on the High Seas. In the old days, you would have been right.

Exclusive Economic Zone

Stretching for up to 200 nm past the territorial seas, the EEZ was a customary norm by at latest 1975 [Gjetnes2000] and was formally introduced in the 1982 UNLOS convention. It is part of the trend towards expanding maritime limits stimulated by the desire to exploit offshore oil and gas resources. The definition of an EEZ is:

A maritime zone seaward of the territorial sea with an outer boundary that may be up to 200 miles out from the territorial sea's baselines. Within this, a coastal state may regulate: (1) nonliving resources, including the seabed, subsoil, and superjacent waters; (2) living resources, including fish, crustaceans, and

plants; (3) other economic resources, such as the production of energy from the water, currents, and winds; (4) artificial islands, installations, and structures; (5) marine scientific research; and (6) pollution control.[IntLawDict]

Some states, such as the United Kingdom, have only claimed jurisdiction over living resources, thus an "Exclusive Fishing Zone" rather than an EEZ, which is more compatible with the seastead way of life. We are not sure if coastal states with EFZ's claim the right to regulate artificial structures. Let's examine each of these provisions:

1. This is not really a problem, seasteads aren't trying to steal oil.
2. Seasteads also aren't trying to steal fishing rights. However, they will want to do mariculture. Thus the question of whether the coastal state can regulate living resources entirely produced, rather than harvested, is important.
3. This is certainly a problem, although it seems rather unfair. If seasteads capture some solar or wind energy, this does not cost the coastal state anything. The clause was probably meant to make sure that if large off-shore power generation becomes cost-effective, states can control it. It seems politically unlikely that seasteads would be prosecuted for generating power in a clean and sustainable fashion, but further research is necessary.
4. This is the most clearly relevant clause. The exact legal differences between ships and artificial structures will be relevant, and seasteads may be able to sidestep this restriction by being ships. If not, this clause makes it pretty clear that coastal states can regulate seasteads in their EEZ.
5. Again, this seems unfair, and politically unlikely to be enforced. If seasteads want to do marine scientific research, they will probably be allowed to. However it is something to keep in mind in case the research is somehow politically sensitive.
6. This gives the coastal state some right to regulate pollution from a seastead. Since we expect seasteads to be very clean, this should not be much of a practical problem. Coming to reasonable agreements with the state should not be hard. However, if there is political tension, the state could impose unreasonable demands through this clause as a means of attack.

it's worth noting that the EEZ is essentially concerned with resources. The law of the coastal state does not apply in the EEZ, and it does not have general enforcement rights. Other than as regards resources, EEZs are counted as the high seas.

Interestingly enough, the US is one of the major objectors to the EEZ system. They are worried that EEZs could become special security zones which restrict the passage of American warships. This could occur through steadily creeping jurisdiction. For example, while pollution controls don't currently apply to warships (gorillas don't need table manners), this could be one route to regulation. They also worry that international straits - narrow passages in key locations - will be regulated. The right of free passage through places like the straights of Gibraltar is key to international maritime trade.

The 200nm EEZ may soon go the way of the 3nm territorial sea. Article 76 of UNLOS suggests that EEZ's may sometimes be extended up to 350nm, or the 2500m isobath, based on the continental slope and sediment thickness of the seafloor. In addition, the 1982 UNLOS and 1994 extension authorized the creation of the International Seabed Authority.

The ISA, which began operation in 1996, has authority over the resources of the seabed of the entire globe.

There are other worrisome signs of this "creeping jurisdiction". After the 1989 Exxon Valdez disaster in Alaskan waters, Chile passed a controversial law in 1991 extending its ocean boundaries 2,000 miles west to Easter Island and south to the Antarctic. So Chile is now unilaterally claiming approximately 1/5th of the Pacific Ocean [StrategicOceans, p. 3].

It is no surprise that, when there are valuable resources present, nations attempt to extend their authority. After all, there is no one there to object. This makes it imperative that the seasteading movement develop before too much of the ocean is claimed, and certainly before too much of it is being actually exploited. Otherwise our legal and political position will be more tenuous, and possible locations more limited. Also, this strengthens [the case for mobile seasteads](refs.html#the case for mobile seasteads), which have the option of moving if political conditions change.

Exclusive Fishing Zone

Some states, rather than claiming full EEZs, only claim Exclusive Fishing Zones. EFZs don't include mineral rights, however we are uncertain whether they include the other regulatory rights. The Mediterranean appears to consist mostly of EFZs rather than EEZs.

High Seas

Finally we get to the high seas, that last bastion of freedom. Subject to some caveats regarding the deep seabed, "In the high seas, the freedom to construct artificial islands and installations is given to all States, whether land-locked or coastal." [Fitzpatrick1998]. While this is nice, it doesn't say anything about the rights of non-States. One can interpret various UN articles to derive that any group of people has the right to form a state [Kardol1999], but this rests on somewhat shaky ground.

To be in the high seas, one must avoid EEZs entirely. The hard way to do this is to be 200 nm from anywhere, which will have a negative impact on many areas of the seaconomy, especially trade and tourism. The easier method is to take advantage of areas, such as the Mediterranean Sea, where EEZs are much smaller or nonexistent.

Special Zones

There are also numerous special cases. A continent-sized example is unsettled Antarctica, which has been portioned out according to an international treaty.

International boundaries are oft disputed and always complex. There are some commercial Geographic Information Systems (GIS) databases containing maritime claims data. These tend to be a bit expensive because they are sold only to governmental organizations, as well as being difficult to produce because of the morass of varying claims. This makes location planning somewhat difficult, although the general distance guidelines help. Seasteaders will probably wish to obtain or make use of these before making any final decisions about location.

A [rough idea of EEZs](refs.html#rough idea of EEZs) can be seen in [SeaAroundUs], though it does not differentiate between EEZs and EFZs. A [list of maritime claims](refs.html#list of maritime claims) can be found in [MaritimeClaims]. A commercial GIS database of maritime claims is sold by Veridian for \$1500/year [GMBD].

Ships

Erwin Strauss summarizes the situation for ships in the book *How To Start Your Own Country*:



Although many countries are expanding their claimed territorial waters, there are likely to be wide areas of the oceans that will remain open to ships of all nations for some time. Treaties that are accepted virtually universally require all ships to fly the flag of an existing nation. Those that do not are defined as pirates, and are subject to treatment as such by any nation's warships. Most nations require ships flying their flag to employ their own nationals, and generally subject them to the onshore laws of that country. However, there are certain small nations that specialize in granting ships the permission to fly their flags with a minimum of restrictions. In return, these countries receive annual fees in the range of a few thousand dollars per ship or less. These flags are called "flags of convenience," and the owners of ships flying those flags are allowed to hire anyone they want, and generally do just about anything they want. Certain international treaties banning piracy, the drug traffic, the slave trade, etc., still apply, but the countries involved are small and can hardly police their worldwide fleets - and aren't really interested in doing so.

[Strauss1984, page 24]

In a sense, these flags serve as a sort of franchised sovereignty, extending the territory of existing nations.

Artificial Islands / Installations

Since we're dealing with the law, we need a precise legal definition for these terms: "Artificial islands and installations are man-made, surrounded by water from all sides, above water at high tide, supposed to stay at a specific geographical location for a certain span of time, and stationary in their normal mode of operation at sea." [Fitzpatrick1998]. So anchored seasteads clearly fit the definition and powered seasteads which move constantly do not (they'd be classified as ships). it's not clear from this how we'd classify drifting seasteads (unpowered, unanchored).

Next we have the difference between artificial islands and installations: "Artificial islands can be distinguished from installations, by asking whether the whole artifact can be moved

from its location at sea without losing its integrity, If it can be moved, it qualifies as an installation. If it is impossible to move it qualifies as an artificial island.” [Fitzpatrick1998] From this we see that of the two choices, our seastead design is an ”installation”. Platforms on pillars connected to the ground would be artificial islands.

Only the coastal state may build artificial islands and installations in its [territorial sea](refs.html#territorial sea). Only the coastal state can build artificial islands in its EEZ, as well as installations which serve an economic purpose. Artificial islands and installations in the EEZ are regulated by the coastal state, they don’t get the franchised sovereignty of a flag. On the [High Seas](refs.html#High Seas), however, any state can build artificial islands and installations. This does not extend its maritime zones, nor are such artificial islands and installations entitled to a territorial sea. They can, however, claim a safety zone of up to 500 meters where they can regulate traffic and navigation, according to [Fitzpatrick1998], from UNLOS Articles 60(4) and 80. Such installations are not entitled to an EEZ or continental shelf claim (and neither is an island which ”cannot sustain human habitation or economic life of its own”, from UNLOS Article 121.3, interpreted in [Gjetnes2000, pp. 48-73]).

Wikipedia discusses the political problems constructing artificial islands:

Legal quandaries similar to the statehood of Sealand are no longer possible today. Since the third conference on the laws of the sea, the nearest neighboring state is now required to consent to the construction of any artificial island pursuant to the convention on the laws of the sea of the United Nations on December 10, 1982, in Montego Bay. Moreover, this convention requires the neighboring state to pull down the artificial constructions immediately after use or to have them removed.

According to this convention, there is no transitional law and no possibility to consent to the existence of such a construction which was previously approved or built by the neighboring state. This means that it is unimaginable that a case like Sealand will ever occur again. An artificial island can no longer be constructed and then claimed as a sovereign state, or as state territory for the purposes of extension of an exclusive economic zone or territorial waters.

[Wikipedia-Sealand]

SOLAS

The set of rules relating to maritime safety is the International Convention for the Safety of Life at Sea, known as SOLAS. It was first created in 1914 in response to the Titanic disaster, and has been under the auspices of the International Maritime Organization since it was created in 1960. While the latest Convention was adopted in 1974, it has been amended and updated many times since this. It sets standards in many areas, including compartment subdivisions (II-1), fire protection (II-2), lifesavers (III), and dangerous goods (VII). SOLAS mandates the international Safety Management (ISM) code, which can be tedious to comply with.

These laws are not difficult to comply with. They require a small number of highly trained crew, and most roles can be learned with minimal training. In the case of an accident, having followed proper procedures (logging of watches, position and so forth) will reduce potential liability.



UNLOS

Currently, the closest to a unified body of rules governing the oceans is the United Nations Law of the Sea, a convention negotiated between 1973 and 1982. While it has been signed by 157 states (as of 2003), the number of signatories to later modifications is much lower. Also, the current global superpower, the USA, never signed the original treaty due to disagreements about the deep seabed mining provisions [Reagan1983]. However, these portions of the UNLOS have been modified by the Agreement relating to the implementation of Part XI of the Convention. The US has agreed to the revision (along with many other nations).

Enforcement

Enforcement of this morass, however, is pretty spotty. It's not like there are international safety officers on board every ship, and it's hard to monitor the ocean or every ship in it. Organizations like the IMO which help make the rules have no enforcement power. As one source says: *"both the IMO and the UN are bureaucracies without the resources to enforce the laws and actually prevent such abuses."*[StrategicOceans, p. 4]

It's mostly up to flagging countries, and no one has much incentive to enforce the rules. To address the lack of oversight by flaggers, more power is being given to ports. Fortunately, most seasteams won't need to call at ports, and so they can sidestep this control. Of course, they should pick and choose when to buck the system and when to go along with it. Complying with sensible safety regulations seems like a no-brainer.

Boarding, Arrest, Search, Seizure

{ we are still researching this section, it's under construction - P }

The basic rules for boarding and search are that permission of either the captain, the owner, or the flagging country is necessary. There is also the "right of approach and visit", which allows a nation to approach a vessel to verify its nationality. It can then board when it has reason to question that nationality, the vessel is without nationality, or engaged



in piracy, slavery, or unauthorized broadcasts UNLOS art. 110). A country can also do whatever it likes in its territorial waters and contiguous zone. Outside, when dealing with ships flagged by other countries, its rights are much more limited:

Maritime law enforcement action may be taken against a flag vessel of one nation within the national waters of another nation when there are reasonable grounds for believing that the vessel is engaged in violation of the coastal nation's laws applicable in those waters, including the illicit traffic of drugs. Similarly, such law enforcement action may be taken against foreign flag vessels without authorization of the flag nation in the coastal nation's contiguous zone (for fiscal, immigration, sanitary and customs violations), in the exclusive economic zone (for all natural resources violations), and over the continental shelf (for seabed resource violations). In the particular case of counter-drug law enforcement (of primary interest to the Department of Defense), coastal nation law enforcement can take place in its internal waters, archipelagic waters, territorial sea, or contiguous zone without the authorization of the flag nation. Otherwise, such a vessel is generally subject to the exclusive jurisdiction of the nation of the flag it flies. Important exceptions to that principle are...

[NWP-LAW 3.11.2.2]

Note that outside the contiguous zone, only natural resource and seabed violations may be unilaterally investigated.

It is worth noting that the US Coast Guard (aided by the Navy) does not even stick to these permissive rules. They board and search suspected drug-runners without bothering to get permission in advance. This reminds us of the 800-pound gorilla in the old joke: Where does he sit? Anywhere he wants to...

An excellent and depressing review of US legal precedent can be found in [Kopel2001]. We reproduce the key sections here:

The *Svesda Maru* was spotted by a U.S. Customs airplane, stopped by a U.S. Navy Guided Missile Frigate some 1,500 miles from U.S. shores and boarded by an accompanying Coast Guard Law Enforcement Detachment (LEDET) who searched the ship for five days before being relieved by an actual Coast Guard Cutter, whose crew found the drugs.

The U.S. Code (Title 14, sect. 89) gives the Coast Guard the authority to "At any time, to go on board of any vessel subject to the jurisdiction, or to the operation of any law, of the United States, address inquiries to those on board, examine the ships documents and examine, inspect and search the vessel" In other words, Congress has repealed the Fourth Amendment for everyone on a ship.

The Coast Guard can come onboard and snoop around whenever it wants. Recreational boaters in coastal waters tell numerous stories about the Coast Guard inviting itself onto fishing boats, sailing sloops, and every other kind of boat, in order to start looking about for a stray joint, as a pretext to seize ship. Federal forfeiture laws promote this form of legalized piracy.

"Coast Guard" naval operations have put the Coast Guard very far from America's coast: in Ecuador, Guatemala, and even on the rivers of land-locked Bolivia. (Likewise, the United States *Border Patrol* has also been sent to Bolivia.) The Coast Guard gets the credit for the bust, but it is the Navy and the Navy's drug interdiction budget that runs the drug war at sea.

One of the authors, Mike Krause, served in the Coast Guard from 1989-1991, including five joint agency Caribbean patrols on the Coast Guard Cutter Hamilton . If the Hamilton wanted to board a foreign vessel in international waters to look for drugs, the crew would simply ask. Now why would the master of a ship, outside U.S. territorial waters, consent to the U.S. Navy/Coast Guard boarding his ship? Because it is more coercion than consent.

The Hamilton was 378-feet long and in addition to her main 3-inch gun and an array of M-60 machine gun mounts, she carried six harpoon missiles on her bow. The captain of a ship in the middle of the ocean would be hard-pressed to turn down a request from a warship capable of blowing him out of the water. This would be similar to a squad of police on your front porch pointing guns in your general direction, then "asking" to come inside and look around.

But even if a ship's captain refused, it really doesn't matter. The Coast Guard already has blanket permission from some nations to board foreign flagged ships.

The *Svesda Maru* was caught in the "Transit Zone", a six million square mile area that includes the Caribbean Sea, the Gulf of Mexico, and the Eastern

Pacific Ocean, over which the U.S. seeks to enforce international anti-smuggling laws, even over foreign vessels and in cooperating nations' sovereign waters.

Only the flagging state, not the owner or captain, can question whether a boarding was appropriate. (Only States have rights in international law, not people.)

Persons charged with a crime under section 1903 do not have standing to raise issues of international law. See 46 U.S.C. app. 1903(d). By enacting section 1903(d), Congress intended to eliminate jurisdictional impediments to convictions under the statute. See S. REP. NO. 99-530, at 16 (1986), reprinted in 1986 U.S.C.C.A.N. 5986, 6001. As set forth in the Senate Report:

"In the view of the Committee, only the flag nation of a vessel should have a right to question whether the Coast Guard has boarded that vessel with the required consent. The international law of jurisdiction is an issue between sovereign nations. Drug smuggling is universally recognized criminal behavior, and defendants should not be allowed to inject these collateral issues into their trials.

...

The exact timing of a flag nation's permission is not a condition to consent under subsection (c)(1)(C). A defendant may be tried for an offense under the statute if the flag nation acquiesces after a vessel is commandeered. See Greer , 223 F.3d at 55 (finding that the United States had jurisdiction over a vessel even when the flag nation consented five years after the completion of the offense).

[USAvBustos]

Warrants are unnecessary for ship searches under US law because ships are mobile and so could be moved while the warrant was being sought. However, probable cause is still required.

We must note that many of these boarding issues are only likely to be worries if drugs are permitted on board. We'll discuss this touchy issue more later. "Although neither convention explicitly says so, it also appears that any warship may seize a merchant vessel that has no nationality. In *United States v. Cortes*, for instance, the United States Court of Appeals for the Fifth Circuit held that the Convention on the High Seas conferred no rights whatsoever on stateless vessels and upheld the seizure of an unregistered ship found by the Coast Guard to be transporting marijuana." [WMDLegal]

Interference

We'd like to admit here that there is a definite danger of other nations interfering in the internal affairs of a seastead. People have quite different viewpoints on how much of a problem this will be, so we'll make our point in two opposite contexts.

First, there are those who ask whether anyone would dare interfere. Will the nations of the world really put up with it? Won't they be worried that they'll be next? Unfortunately, history has made the answer clear. When the meddler is a major world power, there may be squawks but real resistance is unlikely (remember that gorilla). There is always some clever way to spin things, and it will be easy enough to brand seasteads as Communists or Terrorists to justify interference. The big boys have always done what they want, and while

we sure hope that seasteads are a long-term threat to that power structure, in the short-term they have no chance. And don't even think about WMD's as the answer [Strauss1984, 18-24]. Developing them is expensive, and in the current political climate they're a fast track to satrapy for states and incarceration for individuals. In short, this is a nice time to take a deep breath, let those macho urges subside, and reiterate our [philosophy of compromise](refs.html#philosophy of compromise).

On the other side are those who ask what the point of seasteading is. "They'll never let you have any freedom", say these doubters, often libertarians bitter over the steady growth of government power. We think the best answer to this is exactly the same as last time: compromise. "Live free or die" may be romantic, but the land claimed by its adherents generally lies about six feet deeper than they intended. Our goal is not absolute freedom, but whatever degree we can reasonably get. We find the following to be an encouraging exercise for libertarians about just what level is attainable:

Look at current states and consider the union of available freedoms. For example, there are countries in Europe (Switzerland, The Netherlands) with fairly lax drug laws and enforcement (social freedom). There are tax havens (Luxembourg, Bahamas) with very low tax rates (economic freedom). Unfortunately, the drug-tolerant countries tend to be left-wing and have high taxes, while tax havens are more right-wing and socially conservative. We feel that the combination of these two types of freedoms is worth striving for, even if both are restricted to the levels currently being tolerated by the powers-that-be.

It's true that these countries are larger than we'll be, but while this means decreased defense, it also means decreased offensiveness. While things are admittedly easier for established members of the nation-state club, they are not impossible for outsiders (and a country's gotta start somewhere...)

Trouble Back Home

There are a host of reasons why international waters are not a panacea: here is yet another. The United States government claims authority over its citizens worldwide, no matter where they are, no matter where they live, no matter where they have been living. Being in the jurisdiction of another country or in international waters is irrelevant. Even if it chooses to ignore your actions while abroad, it may take action when you return - or forbid your doing so.

This is potentially a serious problem for the seastead tourism industry. However, it is worth noting a few points in our favor. First, monitoring the actions of its citizens will be difficult onboard a seastead. Second, the precedents appear to be fairly positive. Donating to a terrorist organization and fighting on the wrong side of a war have caused the US to take action against its citizens in the past. Smoking dope in Amsterdam and getting unlicensed medical treatments in Mexico have not. Steve Kubby may not have been allowed to ease his rare adrenal cancer with medical marijuana in the US, but they have not stopped him from doing so in nearby Canada, where he is formally seeking political asylum from a California drug possession conviction.

Even permanent residents of a seastead will probably want to travel to the mainland to visit relatives, go to conferences, vacation, etc. As usual, the zealot's response - "Renounce your citizenship and don't go back!" - is not only impractical for the masses but no real protection. Contrary to what you may think, it turns out Americans can't just renounce their citizenship and stop paying taxes. The US reserves the right to keep bleeding its former citizens for up to 10 years if a principal purpose of their expatriation was to avoid

taxes. Certain levels of wealth (\$500K) and income (avg. greater than \$100K over past 5 years) cause an automatic assumption of tax evasion [HIPAA, Title V, subt. B, sec. 511].

Like many governmental policies, the result is to remove the honorable option. No longer can you simply say "I am done here. I would like to start a new life elsewhere. I owe you nothing, please leave me alone." Instead, the choice is to remain part of a system one abhors or sneak away. If you decide the latter, it can be hard not to feel like a thief in the night - even if a house running away from an expected burglar is a more appropriate metaphor.

One must also remember that countries can and do take action against non-citizens as well. An example is the Russian programmer Dmitry Sklyarov, who in a reversal of Cold War stereotypes was arrested and jailed when he came to the US to give an academic talk (he was eventually acquitted) [CNET.Sky_02]. The relevant comparison we need to make is not "The consequences of doing X on a seasteed for an american citizen" vs. "No consequences", because the latter is not an available option. It is "The consequences of doing X on a seasteed for an american citizen" vs. "The consequences of doing X on a seasteed for a non-american citizen". Citizenship is irrelevant to many of the things that the US is interested in stopping people from doing outside its borders, like terrorism. (Taxation is a notable exception.)

In many areas citizenship offers more protection, not more danger. A dramatic example comes from the differing treatments of american citizens like the "Portland 6", who fought for the Taliban and were kept in domestic american jails, and the foreign prisoners held in the military prison at Guantanamo Bay without access to lawyers or family. The former were given courtroom trials, the latter will get military tribunals at best.

The actual domestic legal consequences of performing various actions onboard a seasteed will vary widely, and it will be wise for potential residents to discuss them with an appropriate legal specialist. Simply being in international waters does not justify all actions, and some expressions of personal freedom will cause trouble back home. In the short-term, there is not much we can do about it. Continuing to reside in and support such systems, however, only strengthens their stranglehold. While seasteeds may not be magical Zones Without Consequences, they can still offer concealment, refuge, and acceptance. Most importantly, in the long-run, they give us a chance for a better way of life.

Drugs

Drugs have a special legal status:

All nations are required to cooperate in the suppression of the illicit traffic in narcotic drugs and psychotropic substances in international waters. International law permits any nation which has reasonable grounds to suspect that a ship flying its flag is engaged in such traffic to request the cooperation of other nations in effecting its seizure. International law also permits a nation which has reasonable grounds for believing that a vessel exercising freedom of navigation in accordance with international law and flying the flag or displaying the marks of registry of another nation is engaged in illegal drug trafficking to request confirmation of registry and, if confirmed, request authorization from the flag nation to take appropriate action with regard to that vessel. Coast Guard personnel, embarked on Coast Guard cutters or U.S. Navy ships, regularly board, search and take law enforcement action aboard foreign-flagged vessels pursuant to such special arrangements or standing, bilateral agreements with the flag state. (See

paragraph 3.11.3.2 regarding utilization of U.S. Navy assets in the support of U.S. counterdrug efforts.)
[NWP-LAW, 3.8]

Note that permission of the flagging state is required. Seasteads, if they use a flag, may wish to pick a country which does not have such a standing agreement with the US.

There are many activities, illegal in most of the world, which seasteaders may want to use their freedom to engage in. Recreational drugs, however, bear special mention. On the one hand, local production and use of drugs does not hurt the rest of the world. Producing drugs takes relatively little capital and can produce huge profits. Because of the widespread prohibitionism in the world today and the huge demand for recreational drugs, they are a potentially appealing amenity to enhance the unique seastead experience.

Unfortunately, the political problems involved are huge. The "War on Drugs" is at the forefront of eroding civil liberties, partly because the "war" metaphor suggests a need to win at all costs. Ordinary considerations of property, due process, privacy, and sovereignty go out the window. For example, most of the flagrant, marginally-legal boarding/search/seizure discussed earlier is done to prevent drug smuggling.

While this is a depressing state of affairs, the fact that a single type of activity is responsible for so much state interference suggests a strategy. Namely that by avoiding or restricting that activity, seasteads reduce a large part of their political liability while reducing only one facet of their freedom. Purists will find this unacceptable, and indeed some of your authors have rather strong feelings on the subject. Along with many potential seasteaders, we see legalized drugs as a definite positive. However, we would much rather have a viable seastead with prohibition than to see the project fail because of this political hot potato. Remember our philosophies of compromise, incrementalism, and political realism.

There will be some difficult decisions to make on the drug issue, as with other areas of seastead freedom. There are many potential compromises available. The political feasibility of drugs may be strongly location dependent. For example, it is likely that a drug-legal seastead simply cannot be located in the Caribbean, because of US paranoia. On the other hand, DeepSeasteads will probably be fine. Seasteads near populated but less anti-drug-crazed areas (ie Europe) may also be alright. The [separation of risks strategy](refs.html#separation of risks strategy) we mention later can be applied to the drug issue.

Another possibility is centered on the observation that nations care much more about drug smuggling than drug use. Their goal is more to make sure their laws are enforced than to inflict those laws on others. Even those who think drugs ought to be legal may have some acceptance of states' desire to enforce their own laws on their own citizens. Seasteads could thus allow personal use, while banning large-scale production. This is the approach taken by the more liberal European nations, hence it may well be acceptable nearby. The seastead could even take on some of the enforcement burden with a technique like using drug-sniffing dogs on people as they exit. A "***Do It Here - And Leave It Here***" sort of policy.

Unfortunately, we must add that the sequel to the War on Drugs, namely the War on Terrorism, may add another politically incorrect activity. Libertarian seasteads are likely to be anti-taxes and pro-bank secrecy. Banks with high secrecy can be used for money laundering by terrorists, hence the US may choose to interfere forcefully. The same approach should be taken: identify and evaluate the risks, compare the risks to the gains, look for compromises, and act accordingly.

17.2 Political Approaches

{ Should this be moved into more of a "do" section rather than a "describe" section? ie maybe in "Making Things Happen"? Or is it good to talk about both things at once? }

Erwin Strauss summarizes the importance of this issue, as well as how often it is ignored:

When people begin to dream about starting a new country, usually one of the first things they think about is how the country is going to be structured internally...it can at least be said that people are thinking about these problems, which is more than can often be said about some other problems of new countries; problems which have proved fatal to new countries far more than problems of internal organization.

The problem that is most fundamental to a new country is simple survival. The greatest threat to a new country (assuming that its organizers are able to get it off the ground in the first place) is already-existing countries. How can a new country avoid being snuffed out by the established countries as soon as it comes into existence, or shortly thereafter? Grappling with this problem falls into the sphere of human activity known as diplomacy. But diplomacy is a complex business. It is very hard to understand what is going on in the diplomatic world at any time, especially for someone who is not a trained and experienced diplomat.

[Strauss1984, pp. 4-5]

Strauss also discusses why existing countries are likely to dispute claims to territory:

If a new country stakes a claim and is allowed to get away with it, it shuts out the interests of not just one or two nations, but all nations. If such a precedent were allowed to stand, the entire seabed or continent of Antarctica or space itself could be nibbled away by various freelance claimants, leaving the established nations with nothing in those areas. Thus new countries moving into those areas are moving against the interests of the whole body of established nations.

[Strauss1984, p. 9]

While it's hard to argue with this analysis of the incentives of new nations, we think that the unique nature of seasteads offer a chance to work around the problem. If seasteads only have jurisdiction over their own mobile structure, not claiming any "real" territory, it is possible that they will not be seen as a threat. After all, they can always be forced to move. If this seems far-fetched, consider that the tonnage of ships plying the world's oceans has been increasing steadily without nations worrying that the oceans are being taken over. The ships are perpetually moving, and they claim no territory - the same can be true of seasteads.

Which Zone?

Territorial Seas

Unless they can achieve an unprecedented treaty for sovereignty, this area is pretty much out for sovereign seasteading. It is a good place for non-sovereign platforms.

Contiguous Zone

This is much the same.

Exclusive Economic Zone

While states' rights here are limited, As described in the definition of EEZ, the clauses do create some problems for seasteads. The assistance of a legal expert will be necessary to determine how serious these are. Seasteads may qualify as regulated artificial installations, they will certainly want to capture some energy, probably do some marine research, and will have to emit some (probably tiny) amount of pollution.

Still, the EEZ is the first point at which real autonomy is possible. Although the coastal state does have jurisdiction over resources, it does not have total sovereignty over these waters. "other States have the freedom of navigation and overflight and of the laying of submarine cables and pipelines, and other internationally lawful uses of the sea related to those freedoms" [Gjetnes2000] citing UNLOS, Article 58. Thus mobile seasteads are clearly allowed to pass through EEZ's. (it's unclear whether drifting counts as "navigation".) In some ways, this approach parallels the idea of "Perpetual Tourism", an approach used by some freedom seekers. It consists of moving from country to country frequently enough (a few months or years) to never be considered a taxable resident anywhere. This takes advantage of a status intended for temporary travelers to form a permanent lifestyle.

Even for anchored seasteads, things are "EEZier" in this zone. While sovereignty treaties are difficult and have little precedent, Sean Hastings has pointed out that resource usage agreements are much more conventional. While it definitely complicates matters, it may well be possible for a seastead to negotiate a treaty to anchor and harvest renewable resources for some reasonable fee. it's tough to argue that small-scale wind generators or PV panels impose any real cost on nearby states. The main point of EEZ's and continental shelf claims is to control valuable natural resources (oil, gas, minerals). By giving up all such rights, seasteads can co-exist peacefully with other uses, and thus any revenue from them represents pure profit for the coastal state. Of course, political considerations may weigh more heavily than economic ones.

Exclusive Fishing Zone

The suitability of these zones depend on which of the rights they claim. If it's fishing only, then this is a great location for a seastead. But if they claim some of the other rights (ie everything but minerals/oil), they would be no better than EEZs.

High Seas

This is the least politically problematic place for seasteads. Unfortunately, it's also the toughest economically, as they'll be far away from the land-based economy. And while States don't have specific interference rights in the high seas, there is nothing prohibiting them from doing whatever they want to an unflagged ship, or with the flaggers permission. And as we'll mention later, that permission can come later (even years later) to render their actions legitimate.

Special Zones

Seasteads have to watch out for these cases, but a carefully selected one could also prove the key to achieving freedom at less than 200nm from land.

Flag Of Convenience

The Outlaw Sea describes the colorful history of FOC's:

The system in its modern form, generally known as "flags of convenience", began in the early days of WWII as an American invention sanctioned by the US government to circumvent its own neutrality laws. The idea was to allow

American-owned ships to be re-flagged as Panamanian and used to deliver materials to Britain without concern that their action (or loss) would drag the US unintentionally into war. Afterward of course, the US did join the war - only to emerge several years later with the largest ship registry in the world. By then the purely economic benefits of the Panamanian arrangement had become clear: it would allow the industry to escape the high costs of hiring American crews, to reduce the burdens imposed by stringent regulation, to limit the financial consequences of the occasional foundering or loss of a ship. And so an exodus occurred. For the same reasons, a group of American oil companies subsequently created the Liberian registry (based at first in New York) for their tankers, as a "development" or international aid project. Again the scheme was sanctioned by the US government, this time by idealists at the Department of State.

For several decades these two quasi-colonial registries, which attracted shipowners from around the world, maintained reasonably high technical standards, perhaps because behind the scenes they were still subject to some control by the "gentleman's club" of traditional maritime powers - principally Europe and the US. In the 1980s, however, a slew of other countries woke up to the potential for revenues and began to create their own registries to compete for business. The result was a sudden expansion in flags of convenience, and a corresponding loss of control. This happened in the context of an increasingly strong internationalist democratic ideal, by which all countries were formally considered to be equal. The trend accelerated in the 1990s, and paradoxically in direct reaction to a United Nations effort to impose order by demanding a "genuine link" between a ship and its flag - a vague requirement that, typically, was subverted by the righteous "compliance" of everyone involved.

These developments were seemingly as organic as they were calculated or man-made. For the shipowners, they amounted to a profound liberation. By shopping globally, they found that they could choose the laws that were applied to them, rather than haplessly submitting to the jurisdictions of their native countries. The advantages were so great that even the most conservative and well-established shipowners, who were perhaps not naturally inclined to abandon the confines of the nation-state, found that they had no choice but to do so. What's more, because of the registration fees the shipowners could offer to cash-strapped governments and corrupt officials, the various flags competed for business, and the deals kept getting better. The resulting arrangement, though deeply subversive, has an undeniably elegant design. It constitutes an exact reversal of sovereignty's intent and a perfect mockery of national conceits. It is free enterprise at its freest, a logic taken to extremes. [Lange2004, pp 5-7]

Thus we see several possible courses of action, under current international law. The traditional method would be to buy a flag of convenience (FOC), shop around for a country that has the least objectionable laws and rates, and count on the seller's apathy to minimize restrictions. A seastead is potentially high-profile, and if it proves a serious embarrassment to a registrar it may lose its flag. On the other hand, despite several serious incidents like major oil spills, the small and enterprising nations have continued providing such services. And because flagging is a "virtual" market, that is one in which any country in the world can provide the service, there is a decent chance of finding a reasonable deal. While this is not ideal, it is at least a firmly established political category, and thus fits with our general principle of minimizing novelty. Any group is clearly allowed to build a ship and move it around the oceans.

There are a large number of agreements, treaties, and conventions regarding issues as

diverse as environmental protection, resource use, crew safety, minimum wage, holidays, record-keeping and contributions to Seafairers' Welfare Funds. Many nations have signed these, many have not, and they are erratically enforced (it is up to the flagging country to do so). Complying with all these laws would be an onerous process for a project whose goal is freedom, and it is unclear to what degree it will be necessary if we follow the FOC approach. The answer is probably "very little". One Maritime Law consultant writes:

"The Convention on Standards of Training, Certification and Watchkeeping for Seafarers (STCW) establishes internationally recognised minimum standards for seafarers. Nearly all the flags of convenience countries listed on the ITF list are parties to this Convention. The Convention establishes standards for the deck department, engine department and radio department and deals with all members of the ship's complement...despite their participation in the STCW, open registers are less than rigorous in their application of standards and their monitoring of conditions on board the ship....many of them will accept certificates of competency, which meet very low standards." [Ozcayir2000]

Another article says "the operation of flag of convenience fleet is largely uncontrolled and unmonitored...For many States, there is a wide gap between intentions and enforcement" [StrategicOceans, p. 8]. Further evidence of the spotty enforcement by FOC nations comes from the complaints about the system:

Environmentalists and trade union leaders...want an end to the "Flag of Convenience" (FOC) registry system for fishing vessels which, they say, allows widespread illegal and unreported fishing....the owners of some fishing vessels register them with countries that do not enforce international labor, and environmental regulations. Often these vessels will fish in waters under the jurisdiction of developing countries which do not have the resources to enforce existing regulations and the ability to patrol their offshore waters, environmentalists say.

Greenpeace, the International Confederation of Free Trade Unions, the International Transport Workers' Federation and other unions released a report titled: "Troubled Waters: Fishing Pollution and FOCs."

"The FOC problem has reached a point where it is threatening the sustainable development of maritime transport, the protection of the marine environment and the sustainable utilization of marine living resources," it said...

"The way the FOC system works is basically that a country says pay us a fee, we'll register your fishing boat and you're free to fish anywhere, anyway you want to, no questions asked," added Gianni.

[IPS1999]

The choice of FOC country should not merely be a matter of convenience. US law gives the US jurisdiction over "a vessel registered in a foreign nation where the flag nation has consented or waived objection to the enforcement of United States law by the United States." Id. 1903(c)(1)(C). Thus it may be quite important whether or not the flagging country is willing to stand up for us, particularly if the seastead does not have a drug prohibition policy. Because ships have international rights only through their flagging nations, a good relationship is important for many reasons.

Another possibility would be to obtain a flag from a country which formally agreed to a hands-off policy. The seastead would agree to be bound by the flagging country's laws in its interactions with other ships, but would have autonomy for internal affairs. Which affairs

are internal and which external, of course, is a matter for eternal debate. While attractive, this sounds rather like a treaty for sovereignty, and may be correspondingly difficult to obtain.

Yet another possibility, suggested by a reader, is to separate seasteads by political risk. The larger platforms, with substantial capital cost, would avoid high-risk activities such as drug production. Much smaller, perhaps even temporary platforms could be used for these risky activities. When people have the urge to do these things, they go off from the main colony so as to separate the activity. The smaller platforms could even fly a separate flag, making it clear that they are different legal entities.

Flagless

Vessels which are not legitimately registered in any one nation are without nationality and are referred to as "stateless vessels". They are not entitled to fly the flag of any nation and, because they are not entitled to the protection of any nation, they are subject to the jurisdiction of all nations. Accordingly, stateless vessels may be boarded upon being encountered in international waters by a warship or other government vessel and subjected to all appropriate law enforcement actions.

Vessels may be assimilated to a ship without nationality, that is, regarded as a stateless vessel, in some circumstances. The following is a partial list of factors which should be considered in determining whether a vessel is appropriately assimilated to stateless status: a. No claim of nationality b. Multiple claims of nationality (e.g., sailing under two or more flags) c. Contradictory claims or inconsistent indicators of nationality (i.e., master's claim differs from vessel's papers; homeport does not match nationality of flag) d. Changing flags during a voyage e. Removable signboards showing different vessel names and/or homeports f. Absence of anyone admitting to be the master; displaying no name, flag or other identifying characteristics g. Refusal to claim nationality.

[NWP-LAW, 3.11.2.3-4]

More daring seasteads may choose to go flagless, qualifying as artificial islands or installations, or trying to carve a new niche in maritime law.

It is worth noting that some people feel strongly that this is the right course of action. Sean Hastings, former CEO and founder of HavenCo, believes that it's important to differentiate these types of structures from existing ones. Flagging a platform puts it into a conventional category of "ship" from the beginning, thus losing valuable initiative. Instead, make it clear that this is a new way of life and new legal categories are needed.

Another approach implied by this philosophy is to ignore EEZs. If depletable resources (fish, oil) are not touched, and the seastead just anchors itself in an EEZ and only harvests renewable resources, it has a pretty good case that it is not causing any economic harm to anyone. Getting treaties for these things may set a bad precedent. (It will of course be wise to pick the right nation's EEZ.)

While our first inclination is to start out making as few waves as possible, Sean could be right that this will cause problems in the long-term goal of seastead sovereignty. Advice from appropriately specialized lawyers and the aggressiveness of the inhabitants will determine which course is chosen.

The process will definitely take a lot of time, as "the nature of international legal processes does not support the possibility of swift changes. On the contrary, the development of rules

in international law is a time-consuming process” [Gjetnes2000]. The acceptance of a flagless seasteed will be a major advance for the seasteading movement and the cause of political freedom. Unfortunately, since this is not in everyone’s interest, there may be a lot of pressure brought to bear against it happening by the powers-that-be. The only clear thing we can say about the results is that all the wrangling is sure to make some international maritime lawyers a big pile of money.

Non-Sovereign

Sovereignty of some sort may be the main motivation for seasteaders, but it is not the only one. Some goals will be adequately served by platforms within the territorial waters of some country. As oil platforms serve the simple commercial process of profiting from natural resources, so lower-priced seasteed platforms may be useful for fishing bases, industrial processes, military bases, tourism, and so forth.

While this decreases the appeal of a seasteed, it drastically eases the political problems as well. It’s not an approach that we are passionate about, but we’d like to point out that building seasteeds - any seasteeds - will result in experience, income, and reputation with which to pursue the more satisfying, long-term goal of sovereignty. It may not be as romantic or exciting, but the cheaper and more ubiquitous seasteeds become, the more likely they are to achieve successful self-government.

A governmental viewpoint on these matters is given in the 1969 Stratton report, which (among other things) led to the creation of the National Oceanic and Atmospheric Administration (NOAA), part of the US Department of Commerce. It even uses the term ”Seasteed”, drawing a parallel with 19th century homesteading:

**A Plan for ”Seasteeds” **

Finally, coastal zone policies should recognize the desirability of providing an outlet for the energy and innovative talent of individual entrepreneurs. There are many ways in which these energies might be applied, including aquaculture projects and underwater tourism. Under existing law, uncertain and cumbersome procedures for approval of such enterprises effectively foreclose them in most States. Simple, inexpensive procedures are needed to permit individuals and small companies to lease submerged real estate and water rights when consistent with the overall plan of the State Coastal Zone Authority. State action is required most urgently for development within internal and territorial waters. As development extends farther offshore and international legal arrangements are clarified, leasing to permit diversified, nonextractive seabed activities may become feasible.

The suggestion has been made that underwater leases might capture some of the excitement and public interest ignited by the Homestead Act of 1862. Such ”seasteeds” might be offered for extended periods on attractive terms, contingent upon the useful development of the marine tract in a manner that would safeguard necessary navigation, fishing, and other uses of the superjacent waters and would be integrated with the overall plan for development of the coastal zone. Oil, gas, and mineral rights would not be conveyed through a ”seasteed” plan.

[Stratton1969, p. 72]

Approach Summary

We think a good approach is a balanced one. First, seasteads will fly obscure or convenience flags. They will attempt to find flagging countries willing to offer reasonable deals. While growing and establishing themselves as non-threatening, they will occasionally petition for a change in the international law. At the appropriate time, and with good publicity, one or more seasteads will choose not to renew their flags. They'll announce that they aren't bothering anyone, and ask not to be treated as pirates. Their members will actively attend maritime law gatherings and agitate for changes redefining pirates, restricting boardings to real criminals, not harmless pioneers of the new frontier, and so forth. Eventually, and with the help of public opinion, the rules will change.

17.3 Feb. 2009 Meeting

February Maritime Law Meeting

In February 2009, legal research volunteer Jorge & I had lunch with a noted international expert on the Law of the Sea, who we'll call X. We mainly discussed near-shore medical tourism as the initial business model. Here are my notes from the meeting:

There is a tension between credibility and regulation of flagging states. The ones which will monitor you the least also have the least credibility in the world of international law. Patri & Jorge believe we should follow a laddered approach. Start with whoever will take us - Tuvalu, Marshall Islands, Liberia, Panama. See how it goes. If we need more credibility and don't mind the regulation, use bigger states. Incremental! And of course, this isn't one decision b/c seasteading is not monolithic - different ventures can make different choices and we will see how it all works out.

X mentioned that Dubai is building land in international waters (Dubai International Arbitration Centre) partly so that disputes can be resolved by international arbitration experts applying English law, rather than under UAE law. You can go to their website and plug in the amount of your dispute and the number of arbitrators to calculate the cost of arbitration. Great example of using the ocean to get a better regulatory environment.

Jorge points out that seasteads can do the same. And we can declare our corporate law, for example, to be that of Delaware or the Bahamas. (Like Monaco does w/ French law - they sign a copy of every bill) This is great b/c we leverage the best existing systems out there, we don't have to build the system ourselves, and we don't have to establish a new brand. A perfect example of what seasteading is trying to do - mix and match the best legal and political systems worldwide to make something new and better.

Corporations want stability and predictability. They would rather be regulated than unregulated! Oil companies encouraged the continental shelf grab for seabed resources by coastal states - because they wanted to be able to sign a contract w/ a coastal state and be able to depend on it. They would rather a coastal state own the oil than no one own it, even though they have to pay the state for access!

X made it clear that law is about power, money, political capital. Not just rules and regulations. We cannot ignore this. If we don't have powerful stakeholders on our side, then the powerful stakeholders we offend will just change the laws to make our lives hard. Example - American Medical Association (AMA) doesn't like us undercutting the salary of American doctors, pressures CA to make medical cruise ships or CoastSteads illegal (can't dock in US, passengers not allowed to head there from US ports, Americans not allowed to go to Mexico to take a boat there).

But...if we are partnering with a cruise line and/or a health insurance company - we have the balance of power. We can undercut the AMA and get away with it. Crucial part of strategy - leverage existing powerful stakeholders by allying with them.

X points out that getting on a cruise ship in a US port *feels different* than getting on a plane to Thailand, even though it seems like the same to us, based on international law. The expectation of public and customers will be that there is US protections, regardless of actual international law. And that expectation affects politics and law.

Surgical procedures have big reputational issues. Something will go wrong eventually, and the 60 Minutes TV piece writes itself, and then the AMA can shut you down. Again, need powerful allies. Probably better to start with things that don't have disastrous failures, rather than a major procedure like orthopedic surgery. Cosmetic? Dental? Lasik? Let's take it one step at a time, from least radical. Incremental!

X was a big fan of starting on ships. Far cleaner legal situation, backed by centuries of law. Coastal states get to exert oversight when you dock, inspections and so forth. That makes them more comfortable. There is a flagging state, that makes everyone more comfortable.

We need some regulation. Otherwise we will scare the hell out of powerful players and get shut down. And scare off investors, customers, etc. If we do medical tourism under Marshall Island "regulations", the international community will see us as rogues. Even Panama. If we do it under Norwegian regulations, they might respect us.

"Permanent living on the ocean is inevitable." He expects it to happen on the seabed b/c of the problems of the air/water interface (ie waves). But said it is inevitable.

The UN Law of the Sea is *irrelevant* to what a coastal state does in its territory. (P: Look at US arrests of internet gambling magnates.) They can declare *whatever they want* to be illegal in their territory. This is about politics more than it is about law. "There are definitely ways to structure it within existing international law, if you have political support" For example, easiest thing for us is to ally with small island nation to open a free trade zone / business park somewhere in its EEZ. Very strong legal status. (Unfortunately, also in the middle of nowhere - South Pacific). Secondary to that, we need a nation on our side. But will it let us have autonomy? Dunno.

Economic model matters enormously. X really wanted more detail on this, besides "medical tourism", "low-regulation Hong Kong". Both to be convinced our project is economically viable, and to understand exactly what our challenges are - like what stakeholders are threatened / supported by the venture. Politics is shaped by special interests, and law by politics, so it is hard to know what our legal challenges will be without knowing what special interests we threaten/support.

X found the discussion fascinating - "This lunch was not boring! Very interesting!". He had to consciously choose the hat of "what is possible" - as a lawyer, and employee of / consultant to governments, his natural hat is "Here's why you can't do it". But he understands that if that perspective is taken too far you never get any progress for humanity.

He didn't buy / seem to get at all the idea of dynamic geography, which was part of why he was skeptical of the economics, because he didn't see the regulatory advantages. His focus is law, not economics. I didn't feel like this was a point against dynamic geography, since it wasn't that he got the idea and thought it wouldn't work, it seemed more like the economic language / reasoning was alien to him. From what I could tell, he is not a fan of economists in general.

Jorge felt the meeting went really well. X was skeptical of economic details, and he & I tended to get sucked into those. But at a high-level, he is fascinated by the concept, and I suspect when we have something more solid in place that he would be even more intrigued.

Jorge adds: there are two other points that should be noted. The first is that, as X quickly observed, it is generally understood (with the exception of a few natural rights scholars) that the right to free navigation of the seas does not inhere to individuals, but to states. In other words, don't expect governments to recognize that seasteads have any rights to be or travel around international waters without impediment unless the seasteads are answerable to some government. The second is that a governance model for seasteads has existed for a very long time – condominium law.

Chapter 18

Piracy

See FAQ - Pirates Will Get You!

Chapter 19

Biofouling

As we were researching sea structures we ran across the book *Materials for Marine Systems and Structures* edited by Dennis Hasson and C. Robert Crow [Hasson1988]. This book devotes an entire chapter to the topic of biofouling - plant life attaching itself to your flotation device. In other words - barnacles on your bottom! Basically, biofouling occurs in two steps - microfouling followed by macrofouling. Microfouling is the attachment of single celled organisms to the surface. Macrofouling is the attachment of larger organisms such as barnacles and mussels. Macrofouling is strongly dependent on proximity to the shore, so the further you are from shore, the less of a problem it is.

Biofouling has a number of negative consequences. Barnacles increase drag (from moving, or from currents while anchored), which creates additional structural stresses. Some secrete corrosive acids which are concentrated because they are trapped in the area under the barnacle. They make it difficult to inspect or to re-coat a surface, both of which are very important in the harsh ocean environment.

Some offshore structures just add thickness to offset the corrosion expected during the structures lifetime. Since we'd like seasteads to have very long lifetimes, this is problematic. Another option is anti-fouling coatings, such as paints and metal alloys. The paints only last a couple years, so the alloy coatings (copper-nickel is popular) are a much better option. While these coatings are somewhat harmful to the environment, they are not as bad as the previous tin-based coatings. Research is underway to find new compounds, based on marine life, which are even more environmentally safe.

Another option is to periodically use a biocide like chlorine:

There is no consensus about the concentration of chlorine needed to control macrofouling. Similarly, no agreement has been reached about the relative advantages of low-level continuous chlorination compared to intermittent chlorination and the application rates depend on a variety of factors, including the predominant organisms, growth rates, location, season, and water temperature. In general, the soft macrofouling organisms can be controlled by intermittent chlorination at a level of 1.0mg/L residual chlorine for one hour out of every eight hours. Hardshelled foulers including barnacles and mussels, require continuous discharge of low-level chlorination - 0.25-0.5mg/L of free residual chlorine. [Hasson1988], p 115

If biofouling becomes a major problem for the seastead, a system for chlorinating the water around the seastead may need to be developed. Since chlorine is a nasty chemical

to deal with, we hope that macrofouling does not become a problem for the deep seasteed. This method also poses problems for seasteed aquaculture.

Reader W.E. Johns suggests that biofouling might be turned to a benefit. If the seasteed can be made corrosion-resistant (rather than poisonous), the growth of a little ecosystem might help aquaculture, attract fish, etc. And there is no drag on a drifting seasteed. Another reader suggests encasing the submerged portion of the platform in a plastic bag that could be occasionally replaced.

Chapter 20

Ocean Misc

20.1 Sewer Ice

[USGSHydrates][NMHP]

{ I don't think seasteads actually need to worry about this stuff much. But it's an interesting weird science-fictiony true phenomenon, and I think that sort of thing adds some nice flavor - P }

Methane hydrate is a crystalline solid that consists of methane surrounded by a cage of water molecules. It looks much like water ice. This strange substance, found in vast quantities in permafrost and on the ocean floor, has a fascinating history. Natural hydrates were first found in the 1930s when chlorine hydrate (a similar material with chlorine instead of methane) plugged natural gas pipelines. Most research focused on preventing their formation.

In the 1960s, scientists discovered naturally occurring methane hydrate in Siberian gas reservoirs. Before this period, methane hydrate was thought of as an unusual and unnatural substance that only occurred in chem labs and gas pipelines. No one suspected that it was common in nature, let alone in the vast amounts which we currently estimate. Stable at

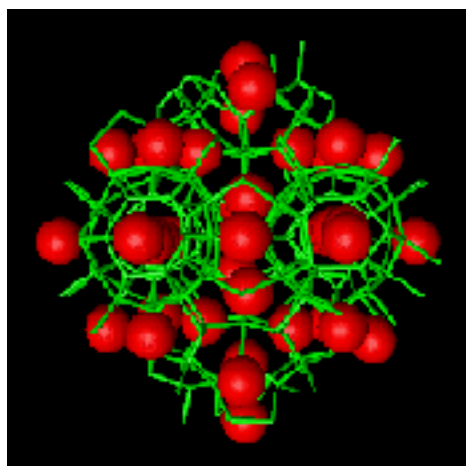



depths greater than 300m, it melts quickly when removed from its natural environment. Because of this, it was not actually seen until 1974, when Soviet scientists successfully recovered nodules from the floor of the Black Sea.

Methane is the byproduct of bacterial breakdown of organic matter (ie "rotting"), which also creates hydrogen sulfide, which our noses recognize as sewer gas. Since organic material constantly falls to the ocean floor, in retrospect it makes sense that bacteria there digest it. On land, methane escapes into the atmosphere, but on the ocean floor, low temperatures and high pressures trap it into sewer ice.

The oceans have been around for quite awhile, and the earth's reserves of this previously unknown substance are staggering. Methane hydrates are conservatively estimated to contain twice as much carbon as all other known fossil fuels, and this discovery means that scientists need to re-think the global carbon cycle. It has naturally been considered as a possible fuel, and a number of governments are digesting this possibility. Fantastic though it sounds, frozen flatulence may fuel the future!

More seriously, this discovery poses some serious worries on the global warming front. Methane is ten times more effective a greenhouse gas than carbon dioxide, and so much of it is trapped in hydrates that it could have a major effect on our climate. This might happen through a dangerous feedback loop. First, some other effect causes a slight warming of the earth, including its oceans. This melts some methane hydrate, releasing methane into the atmosphere. This adds to the greenhouse effect, making temperatures go up more, and the cycle repeats. In fact, Dr. Euan Nisbet of the University of Saskatchewan thinks this effect may have been behind the rapid climate change which followed the last glaciation [Nisbet1990].

The most recent twist in this strange tale comes from Monash University in Australia. Researchers there have theorized that some unexplained ship sinkings may have been caused by giant bubbles of methane. These bubbles are released occasionally when methane hydrate melts. If one of these bubbles comes up underneath a ship, the ship will briefly lose buoyancy (since it's sitting on gas instead of water). Depending on the location of the bubble (experiments suggest that off to one side is the most dangerous), the ship may capsize. In fact, a sunken vessel has been found in the North Sea in the center of a large methane eruption site called the Witches Hole. As if drowning isn't bad enough, imagine your last sensation being the overpowering smell of rotting eggs... [Fox03]

To avoid this awful fate, permanently moored seasteads should be aware of any methane hydrate deposits beneath them. Travelling platforms may just take it in stride as one of the many "hazards of the sea", although it's also possible that clever engineering or warning systems could reduce the danger. Future seasteads may find methane hydrate mining to be a profitable activity. This could be a huge industry, as it seems quite possible that it will be

the next generation of fossil fuels - although if so, we're going need a whole new generation of noseplugs!

20.2 Upwellings

One reason why the sea is a much harsher environment for life than land is that when things die on land, their remains are readily available for scavenging. When things die in the ocean, they sink to the ocean floor, removing useful resources from the food chain. Natural upwelling zones, which constitute only about 1% of the oceans surface, produce approximately half of the worlds fish.

Some seastead power technologies, like OTEC and [wave pumps] create upwellings as a side-effect, which may be very useful for growing things.

Part V

Structure Designs

Chapter 21

Design Intro

{This section feels a bit incomplete. We've had to leave out a lot of engineering information, as there is neither space for us to describe everything in detail, nor time for us to finish all plans to completion now. But we still want to hit all the major points, so let us know if we've missed something that seems crucial to you. }

There is no one correct design for a seasteed, since the best choice depends on your goals, budget, and location. For this reason we'll give a broad overview of the many types of structures which have been suggested and some of the necessary tradeoffs. Then we'll delve into detail on our favorite design, the spar platform.

The most important design criterion is that the seasteed be safe in the harsh ocean environment, with its wind, waves, and currents. Thus all of these designs will need to use some of our wave avoidance techniques. Besides safety, the structure must be reasonably cost-effective, or it will never be built. Cost may well be the main barrier which has prevented people from becoming seasteaders. It's also important that the design scale well to different sizes, so that we can apply our incrementalism approach. [Dynamic Geography] tells us that physical modularity is also very desirable.

Seasteed designs break down into three rough categories, depending on their location relative to the water's surface.

Chapter 22

Underwater

While there are some neat benefits to an undersea structure, there are a large number of disadvantages and engineering challenges as well.

Advantages

- Protected from the elements: No waves or wind. Most living creatures on the ocean live either above the water (birds) or below it (fish). The air/water interface (as engineers call it) is a brutal place, and avoiding it is a huge win.
- Scenic: Will have a great view if it's in the right location.
- Unique: Underwater resorts draw customers. For example, Jules Undersea Lodge off Key Largo, Florida, charges \$300-\$600/night.
- Hidden: Can be very isolated, defensible and hard to find, if desired.
- Cheap to expand: By using clever construction methods, expanding the colony volume might be fairly inexpensive. A variation on the technique used to build Monolithic Domes seems promising [MDI]. Fill a plastic form with water, then spray or layer on concrete and insulation. When the concrete has set and can take the pressure, pump

Figure 22.1:



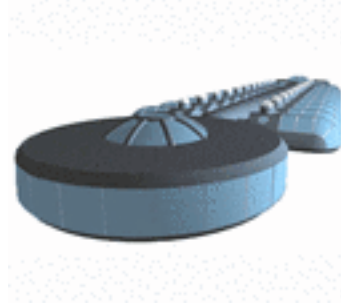

the water out and pump air in, and you have a new airspace. If the colony is not very deep (so water pressure is low), the form can simply be inflated with air from the beginning.

Disadvantages

- **Bad failure mode:** If other seastead designs fail, residents end up on top of the ocean. If an underwater structure fails, the ocean ends up on top of them!
- **Psychological difficulties:** Access to fresh air and sunlight will be difficult, and combined with lack of open space makes for a very challenging environment for humans. Submarines, for example, are notoriously challenging psychological environments. Some air and sunlight can be piped in from the surface, but getting large amounts of sun will require large structures at the surface.
- **Additional engineering difficulties:** Building a seastead is already difficult. Building an underwater one will be even harder, especially at any significant depth (more than 200 feet or so).
- **Difficult to get in and out:** If the structure is kept at atmospheric pressure, it has additional structural stresses. If it is kept at the appropriate pressure for its depth, residents have pressure-adjustment problems going to the surface. Either way, complex airlocks are required, or a tube to the surface which is vulnerable to the waves. Not only is this a problem for people, but it makes shipping goods difficult as well.
- **Limited access to energy sources:** The water blocks the sun and waves. While enough sunlight filters down to support plant life in the first couple hundred feet, much of the energy is being absorbed by the water. It might be possible to mount wind turbines on pillars, use currents, or geothermal energy. Still, this makes an already-challenging problem even harder.
- **Altitude control.** The structure either needs to be located someplace shallow (hard to find in international waters), or needs to have extremely reliable height control so as to neither go up to the surface (and be battered by waves) or down to the depths and be crushed by the pressure.

Note that the positive scenic aspect can be achieved just by having a small undersea portion of a structure which is mostly above the water. (Although many seastead locations will just not be very scenic). While avoiding waves is a huge win, the extra expense and

psychological difficulties seem to outweigh that single large advantage. However, if a cheap construction technique can be created and a good location found (seamount), it could be worth a try. Those interested in more ideas about living underwater should see [Fisher1985, pp. 64-73]

Chapter 23

On The Water

This category of designs consists of structures which float directly on the ocean's surface. Since waves are dangerous, these methods will need to somehow avoid them. We'll start with options based on modifying existing designs, and move on to more novel ideas.

23.1 Sailboat Fleet

*"A boat is a hole in the water
into which you throw money."*

While we have not found any published literature on this concept, it is unlikely that we are the first to think of it. The concept is that a group of like minded people could purchase a bunch of sailboats different sizes and costs and sail around the ocean together. The standard self-sufficiency technologies described later would be used to provide electricity, fresh water, etc.





There are several advantages to this idea. Obviously sailboats are a mature technology, with a large number of types, repair facilities, books and so forth available. They are extremely mobile using renewable energy, and can thus travel all over the world living in "endless summer". While they are not built for extremely rough seas, they are mobile enough that with advance planning they should be able to avoid such situations. And a fleet of sailboats is both modular and scalable. They can even grow some food, as described in *Sailing the Farm* Neumeyer1982. Unfortunately, there are serious drawbacks.

Boats tend to be built from expensive materials, and are costly to build and maintain. They are optimized for movement, so they have have small deck areas (tough for solar panels and greenhouses) and cramped interiors (tough for living in). Nor are they particularly comfortable in significant waves. The marketing/publicity angle is more difficult because it doesn't seem like a new way of life. We cover these problems in more detail in the FAQ question Why not just buy a boat?.

There are definitely some nice aspects to a fleet of sailboats, such as not having to design a new structure. It would be a relatively easy way to start living on the water, since there are people already doing it. But boats are designed to travel from place to place across the ocean, not to live in. The difference between a sailboat and a seastead is like that between a house and a car. Sure, you can live in a van or RV, but it's just not that comfortable. The residents would be more wandering nomads than permanent settlers. There is nothing wrong with this lifestyle, but it's not what we think of as true seasteading.

23.2 Big Boat

Many people have suggested that rather than designing a unique structure, seasteaders could just purchase and retrofit a large used vessel such as an oil tanker or cargo ship. Again, the standard self-sufficiency technologies would be used to provide infrastructure. As evidence that big boats make decent floating cities, we need only look at the cruise ship industry. One way to think of this concept is as a low-budget, do-it-yourself cruise ship.

Obtaining a used boat would reduce costs, and it would already contain many useful systems like propulsion and navigation. The propulsion could be used occasionally, although the ship would mostly drift to conserve fuel. Large vessels are less responsive to the waves than small ones and so more comfortable to be on during storms, as well as safer.



Unfortunately, large boats are not exactly scalable, so it would take a sizeable initial group to purchase one. They are also not reconfigurable or modular (although an assembly of multiple ships would be). They have many of the same drawbacks as sailboats, like limited solar area and not seeming like a new way of life. We've basically traded modularity and low starting cost for seaworthiness and some interior volume, without really gaining any ground. Like the sailboat fleet, the idea certainly has some merit, but we don't think it's the most promising option.

Some of these issues can be addressed with a hybrid combination of a cargo ship and some of the platform types described below. The cargo ship would take the materials to some remote island or atoll, and the colony would be deployed. In the event of political problems, bad weather, or simple boredom, the colonists would load everything back onto the boat and move someplace new.

23.3 Simple Platform

In waters that are naturally calm or somehow protected, there are many simple systems that can be used to turn water into land. Each consists of some sort of buoyant foundation on which to put whatever structure is desired. While we'll be recommending a different approach, this one is quite promising as well. In an area without large waves, it would be quite cost-effective, and should be strongly considered as an alternate design.

2 Liter Bottles

One of the simplest systems was suggested by Wayne Gramlich in his original seasteading paper [Gramlich1999]. It utilizes plastic 2-liter beverage bottles, which are extremely common, incredibly cheap, and resistant to sea water. These bottles can be banded together into hexagonal grids of 7 bottles each. The grids are then stacked and layered to form a buoyant lattice. Alternatively, one can use Rich Sowa's method of filling nets with the bottles. Some sort of rigid surface then needs to be placed on top of the flotation.

Inverted Cylinder

[

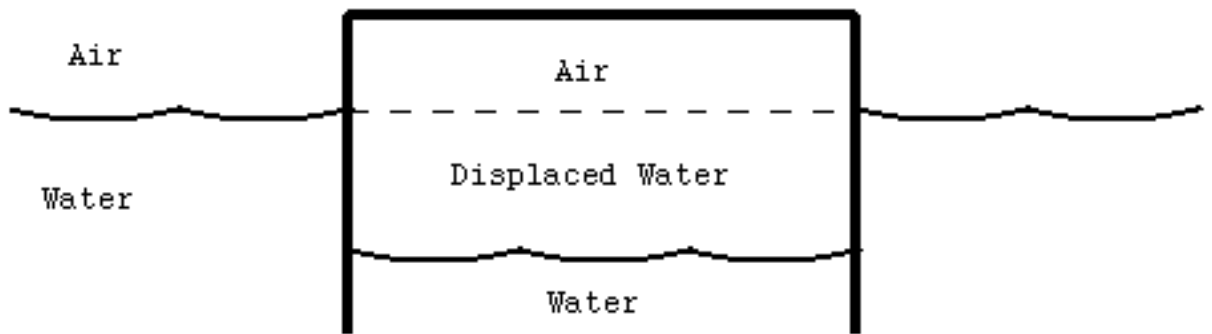
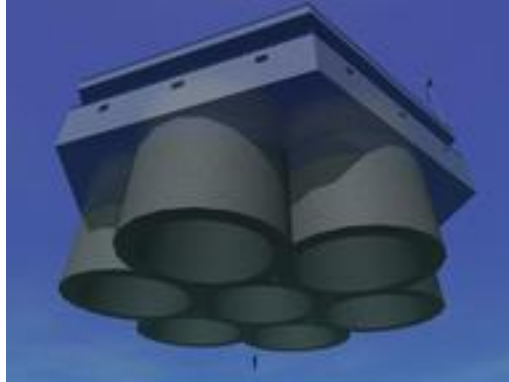

](images/InvertedCylinder2_big.jpg)

[

](images/InvertedCylinder1_big.jpg)

Another simple technique is to have an inverted cylinder, open at the bottom, containing air. This idea was used by Sea Structures Inc. for their SeaCell system [SSI]. A disadvantage with open containers is that as depth increases, the air is compressed and displacement goes down. This flotation is cheap to manufacture, and can be stacked for easy transport. Again, some sort of rigid platform needs to sit on these cells.

Concrete Slabs

[

](images/slab_big.jpg)

Yet another simple method is concrete slabs such as those manufactured by IMF [IMF]. These are hollow boxes of reinforced concrete, with enough buoyancy from the interior airspace to support the concrete as well as a structure. IMF's designs include shock-absorbing connectors, integrated structural cleats and pile rings, and integrated utilities. Because the structures are monolithic and sealed, they cannot take on water and are unsinkable unless broken. And ferrocement is cheap. Most floating homes in the USA nowadays are built on such slabs. They'd be fairly easy to connect to one another, and small ones



could be easily built onboard. We think this is the most promising aquatory technology for protected waters.

23.4 Pneumatically Stabilized Platform

One interesting possibility is the PSP designed by Float Incorporated [FloatInc]. It consists of a number of inverted hollow cylinders, as described earlier, but with a clever addition. Imagine what happens as a wave rolls under these cylinders. The water in each cylinder moves up and down, and the air pressure in the trapped airspace changes. In a PSP, these spaces are connected through pneumatic lines and valves, so that these pressure changes result in air moving between cells. This dampens the waves and distributes their force so as to reduce peak load on the structure. If air turbines are attached to these lines, it becomes a wave-powered electricity generator.

The PSP has some characteristics of a platform (it can support loads) and some of a breakwater (it attenuates waves). It is built out of concrete, our favorite construction material, so it's relatively cheap. It's very modular and fairly reconfigurable. Cost estimates are \$5M - \$7.5M an acre (\$115-\$160/ft² in the open ocean. However the inventors have not been able to find a major purchaser, so this is an unproven technology. We have some



concerns about the design’s ability to withstand (or block) severe storms, with waves large enough to wash over the edge of the platform. Still, it is a promising system.

23.5 Cargo Containers

{ this section could use some trimming - P }

The ideal seastead technology is safe, inexpensive, and modular. Here we’ll consider whether structures built out of converted freight containers qualify.

The shipping industry has been revolutionized by these containers. Freight containers can be moved between trucks, ocean freighters and trains without requiring that the container contents be changed. Their popularity has made them cheap and plentiful. Used 40 ft freight containers can sometimes be obtained for less than a thousand dollars. A similar alternative is large propane tanks, which are much stronger because they’re built to hold pressurized gas. They cost several thousand dollars (used), but this may be worthwhile for safety.

The table below summarizes a number of common container sizes:

Container Length (ft'in")	Width (ft'in")	Height (ft'in")	Volume (ft ³)	TARE (lb)
20' Dry	19'10.5"	8' 8'6"	1,173	5,160
40' Dry	40' 8' 8'6"	2,391	8,730	58,470
40' Hi Cube	40' 8' 9'6"	2,692	9,150	58,050
48' Domestic Dry	48' 8'6"	9'6"	3,463	9,700
53' Domestic Dry	53' 8'6"	9'6"	3,830	10,280

Since the weight of 1 cubic foot of water is 62.4 lb., a sealed container can generate a substantial amount of buoyancy. For example a 40 foot high cube container generates $62.4 \times 2692 - 9150 = 158,831\text{lb}$ or almost 80 tons of buoyancy.

Since freight containers are not designed to float, some effort must be expended to convert them. The basic concept is to weld all holes and vents shut, along with the access doors, and to install a seaworthy access port. It must also be sandblasted and coated with seaworthy paints. It may need some structural reinforcement, as the corrugated steel skin is not meant to withstand much force.

Once the container is seaworthy it is ballasted on one end to force it into a vertical orientation with 1/2 to 2/3 of the container submerged below the water line. This reduces interaction with waves. In a storm with large waves, the structure will basically move up and down with the waves with relatively little rocking motion. Because it's small enough to bob, it doesn't absorb much wave energy. In addition, by submerging a significant fraction of the structure below the water line, there is less swaying due to high winds. This is similar to Marc Piolenc's spar buoy. In a severe storm, the occupants of a container will definitely be pushed around. However, as long as everything is properly secured inside the container, about the worst that will happen is a severe case of sea sickness.

Even though the freight container should be relatively safe in pretty severe weather, it is still prudent to plan on situating freight container seasteads in areas that do not often experience severe weather. It is further prudent to have a means of moving a freight container seastead out of the way of an approaching severe storm. A basic outboard motor should provide the means to move a modest distance even though a freight container is hardly shaped for optimum traversal through water.

One nice characteristic of this design is that it can be easily purchased, stored on inexpensive property during conversion, converted, and then shipped off to an ocean deployment location. Freight containers are designed to be moved around, so it is relatively easy and inexpensive to do so. Ballasting may need to wait until the final site, as it will make the container heavy and unbalanced.

Since it's oriented vertically, we can divide the container into floors. Assuming a 40 foot container on end with approximately 8' ceilings yields 5 floors. The bottom floor will be partially occupied with ballast, so it should really be thought of as a cramped storage compartment rather than a full livable floor. Using a 48' container provides an additional floor and a 53' container might provide two additional floors. Since the dimensions are 8' by 9.5', each floor is 76 ft². This is not luxurious, but for some people it will be adequate. The total area of 300 ft² actually compares favorably with the floor area of a sea worthy sail boat. For more space, multiple containers can be welded together into larger units.

Giving the limited top deck area, we need some creative solutions to provide an adequate supply of food, water, and power. Just like the larger structures we'll propose later, there is no reason why a container seastead can't have a cantilevered upper platform to provide additional solar area. During bad weather, anything kept up here can be stored safely inside. Another simple solution is to tether inexpensive inflatable floats to the seastead. These could support [solar stills][], PV panels, and small greenhouses. Again, in bad weather these are deflated and brought inside.

The primary reason to think about freight containers is to propose alternatives that further lower the cost of bootstrapping seasteading into existence. Will a freight container seastead be as safe in severe weather as one of its larger cousins? Almost certainly not. However, it is probably safe enough that it can seriously be considered as a potential start. As the seastead community gets larger, the need for this design may well diminish as people switch to structures designed specifically for seasteading. Thus, freight container seasteads should really be thought of as a bridging technology between what is available now versus what we can build eventually. Alternatively, they may continue on as low-income housing, much like trailer homes on land.



23.6 Breakwaters

"Any structure or contrivance to break the force of waves, and afford protection from their violence."

A simple example of a breakwater is any island or reef, which acts as a natural barrier for its lee shore. Artificial breakwaters can be seen surrounding the entrances to any marina, usually consisting of concrete piers or piles of rock.

The advantage of using a breakwater is that it eliminates all the problems caused by waves. Structures become much cheaper, safer, and easier to expand, seaplanes can land and cargo is easier to offload. But to do this, you must dissipate the tremendous energy found in ocean waves, and do it continuously, for years on end, even during severe storms. If the breakwater fails, suddenly your structures must face waves they were not designed for, which may be disastrous. We'll outline a number of the different methods that could be used to build such breakwaters. Later we'll explore the question of when this is the best way to deal with waves.

TODO: Add lots more here. Breakwaters are really important - they get us massive cost decreases which are essential to making a country, not just a single fancy hotel or business park. Add Patri's idea for inclined plane breakwater (hopefully cheap).

Natural Breakwaters

Any landmass which reaches close to or above sea level acts as a natural breakwater. Rock is tough stuff, and it takes quite awhile for the ocean to grind it into sand. There are basically two options: we can shelter by a large landmass (which will almost certainly be inhabited), or a small one. Large landmasses have political difficulties, as we will be fairly

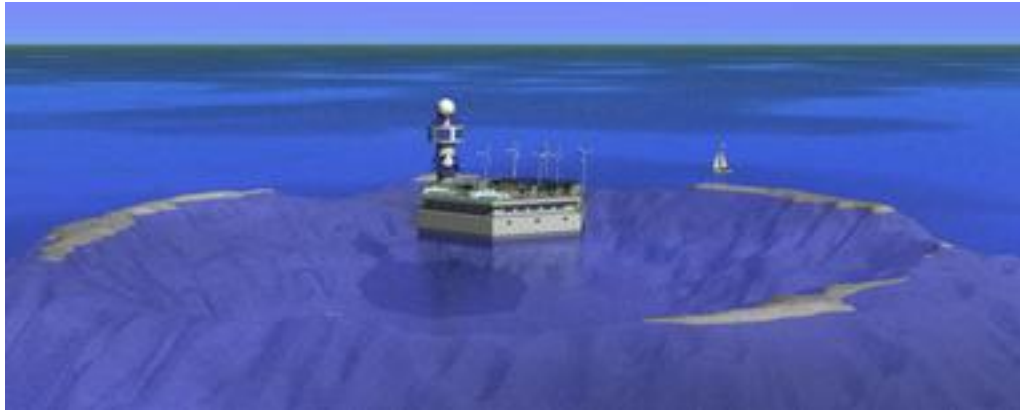

close to existing nations. It is difficult to be protected on all sides yet still be in international waters. Still, there are some possibilities if we are willing to accept moderate waves, such as seas like the Mediterranean.

Smaller breakwaters include atolls, reefs, and seamounts. An atoll is a special class of island that is formed when the ocean has worn a volcanic peak down to a roughly circular shape. As a result, they basically consist of a breakwater surrounding a calm lagoon. Because so many islands are volcanic in origin, atolls are quite common, and many are uninhabited. One of the more famous is the Bikini island atoll in the Marshalls, where the US conducted nuclear testing [Bikini]. These lagoons range in size from tens of thousands of acres down to almost nothing.

Yachtsmen, encountering unexpected storms, have weathered gale-force winds by anchoring in such lagoons, so atolls definitely act as a wave barrier [Fisher1985, p. 52]. Unfortunately, the fact that atolls contain land means that they are all claimed by an existing country. While an abandoned atoll could doubtless be used for awhile before anyone noticed, our goal as seasteaders is to create a stable way of life. We want to be pioneers, not outcasts. This renders claimed atolls unsuitable for frequent use.

The obvious solution is to look for submerged atolls or reefs, which do not count legally as land. After all, a breakwater does not need to extend above water to provide significant protection, it need only come close. These submerged reefs and rocks, formerly only known as hazards to navigation, can be used to protect our new way of life from the elements. While the Minerva incident indicates that nations do not always respect these rules, our chances are much better if we follow them.

Unfortunately, suitable geographic features are likely to be rare. Any rock above water creates a zone of 3-24nm around it of sovereign waters. So we need a reef which is not within that distance of any above-water reef. It can't be too far below water, or it won't be a useful breakwater. So we need an area where the reef comes quite close to the surface, yet never rises above it, and the odds are against this happening.

An additional advantage to such natural breakwaters (if we can find them) is that they provide for cheap and easy anchoring. Also, they are likely to have pretty underwater scenery. A disadvantage is that the colony is tied to one physical location, which means that it cannot easily avoid political problems, move with the seasons, etc.

An alternative to finding a submerged breakwater is to be close enough to some appropriate landmass that it can be used for shelter during severe storms. While the waters would



be legally controlled by another nation, the use would only be occasional and it's unlikely that anyone would be paying attention. Still, satellite photos could be used later as part of some legal maneuver. In an emergency this solution is fine, since any court is more forgiving than Davy Jones Locker, but it seems a poor idea to depend on it.

Artificial Breakwaters

Artificial breakwaters have a long history of use to protect harbors, marinas, and coastlines. There are numerous breakwater designs, and they are fairly simple in principle, so we won't cover them in detail. Most rely on big pieces of concrete, although there are many alternative methods. Most designs are meant to rest on the seafloor, or at least be tethered to it. While this is fine for shallow water (perhaps on a seamount or reef), it won't work in any significant depth. Hence we need a floating breakwater.

Ocean waves can be very large, hence a traditional design would need to be very large. Rather than absorbing all the energy, perhaps we can simply get it to dissipate harmlessly. This may sound difficult, but this can be seen on any beach with a wave break. The incoming waves, reaching shallow water, begin to pile up. They reach an unsustainable height, form the familiar whitecaps, and break, collapsing on themselves. Only a gentle wash reaches the shore. The soothing sounds and pretty patterns on the sand are all that remain of the wave's energy.

This effect could be simulated by submerging a long triangular breakwater. As waves reach it, they will pile up and eventually break. This breakwater does not need to be

particularly strong, because this aikido-like method never takes the brunt of the force. Still, it will need to be quite large, and will not be cheap or easy to build.

Any non-anchored breakwater will be steadily pushed by the waves towards the center colony, so the two must be strongly connected. Many breakwater designs such as the simple concrete wall, the aikido breakwater, and the PSP could be used in such a configuration.

Chapter 24

Above Water

The final option for avoiding waves is to place our structures above water level using pillars made of steel or concrete. Many permanent marine structures, such as oil platforms, use this technique. These "spars" present little cross-sectional area, so that waves pass through without imparting much energy. The extra engineering problems posed by spars are more than balanced by not having to endure the bashing of waves.

24.1 Pillar Platform

Troll deck floating before assembly.

If the water is shallow enough, the pillars can rest directly on the sea floor. Thus there is no movement due to currents, wind, and waves. Unfortunately, pillars are not well-suited to dynamic geography, and they have all the political dangers of a fixed location. While oil

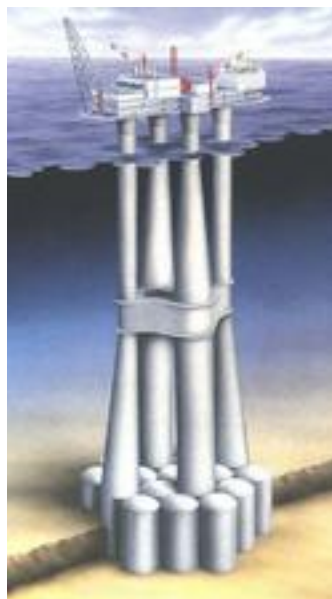



rigs can have pillars as deep as 3000 ft., they also have budgets in the billions, and it will take much shallower waters for a pillared seastead to be cost-effective.

The most impressive example of this type of structure is the massive Troll A gas platform, located in the North Sea off the coast of Norway. Only a handful of skyscrapers and oil rigs are taller, and it became the tallest structure ever moved over the face of the earth when it was towed 174 nautical miles to its operating location. It is built from ferrocement, our material of choice.

Statistics

Height 472m

Expected Lifetime 50-70 years

Total Weight 1,050,000 metric tonnes

Deck Area 8,670 m²

Water Depth 303m

The deck and pillars were built separately and united while floating in a fjord. Norske Shell describes the process:

- On 25 January 1995 the deck and concrete gravity base were mated by the Aker Companies Norwegian Contractors (NC) and Aker Stord.
- Tugboats towed the deck into position in front of the four legs of the concrete base, which were submerged with only 6.5 metres of freeboard
- The barges were drawn in towards the gravity base the last few metres by means of cables
- The most critical phase was positioning the deck on top of the four legs with millimetre precision and transferring the weight from the barges to the gravity base
- Gradually ballast water was pumped out of the base, the barges were removed and the deck gradually rose to 30 metres above the surface of the water

- [NorskeShell]

The design, assembly, and towing of this platform validate a number of our design features which you'll see later. Hence we don't need to demonstrate that such structures are possible, but merely that they can be built cost-effectively.

24.2 Tension Leg platform

Another option is to have pillars which are buoyant and floating, but anchored to the seafloor with tensioned lines. These lines prevent vertical movement, but allow for some horizontal motion. Unlike fixed pillars, a TLP can be detached and moved to a new location. They can operate as deep as 7,000 feet, although the tensioned lines are very expensive.

{ Not sure what else to say here }

24.3 Semisubmersible

_A seagoing, self-propelled barge that rides at anchor, stands on partially submerged vertical legs on submerged pontoons, and serves as living quarters and a base of operations in offshore drilling. - [AHDE4]

This is a standard barge design for places where good weather is infrequent. It has a much lower response to waves than a normal ship, because the waves sweep through between the columns. This allows it to operate in rougher conditions. The disadvantages are related to the weight balance required for stability. The topside cargo capacity is much lower than a ship, because too much weight causes stability problems (the barge becomes topheavy and tips). It needs sophisticated ballast controls, like a submarine, which adds expense compared to a ship.

However, a seastead doesn't have large load requirements, so this is not as much of a problem. This closely resembles our preferred design.

24.4 Floating Spar Platform

The problem with the pillared platform is that it is immobile, and in deep water it requires very long, expensive pillars. The problem with the semisubmersible is that much of its



flotation is close to water level, and its platform is not high enough to avoid all waves. So it escapes some wave force, but not enough. The logical solution is to make tall thin legs, like a pillared platform, but to have them resting on submerged buoyancy, like a semisubmersible. We call this a floating spar platform.

The simplest version is Marc Piolenc's spar buoy concept. This consists of a vertical cylinder ballasted at one end. Essentially, the structure is all spar and nothing else. The ballast must be considerable in order to make the structure float vertically, especially if a substantial portion of the spar is above water. The spar is a suitable design for weak building materials such as seacrete, which cannot handle cantilevered loads. { Picture }

There are some disadvantages to this system, however. Solar area is very important for PV panels, growing food, heating water, etc, and the tip of the spar doesn't give us much. We don't have much living volume either, just what's inside the spar. So its natural to stick a platform on top of the spar, to get a lot more solar area, and make that platform several levels high to get more volume.

Unfortunately, this makes the structure a little more topheavy. Now we need more flotation and ballast to compensate. As we add them to the bottom of the spar, it begins to get very long. The point of the spar is to present a thin front to the waves. This means that once you get below the bottom of the waves, it's not really necessary to use a spar shape. We can simply widen out into a larger flotation chamber.

Combine these observations, and you get our preferred seastead design, which looks somewhat like a dumbbell, possibly with multiple spars:

Having several pillars is necessary for large seasteads, since you can only project the platform out so far. But for smaller platforms, it's easier to just have one spar, since the cantilevering is not as expensive as the multiple spars and connections. This also allows for more modularity. We can build multiple single-spar platforms, and assemble them together to get a multi-spar system.

Later in this chapter we'll present lots more detail on this design.

{? Show William Barkley's ReefHome too?}

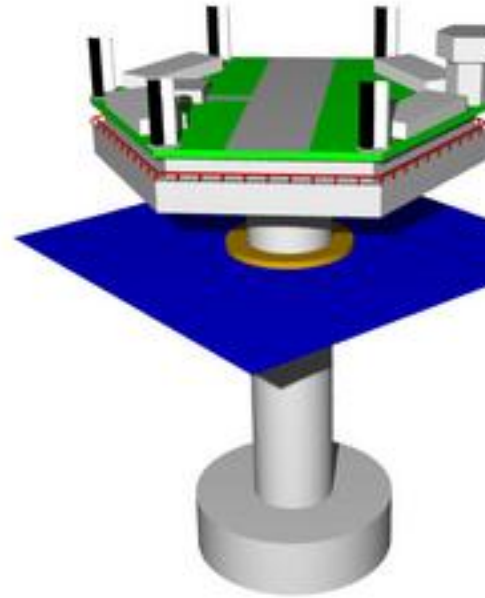
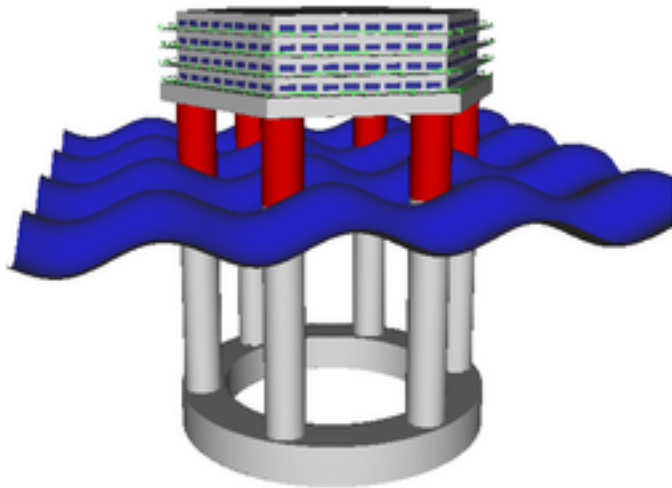

24.5 SWATH

{ not sure if this should go here, SWATH's aren't quite above the water. But they use the same spar design principle } [(images/swath-creed-big.jpg)

When the same concept for avoiding waves is applied to boat design, the result is a Small Waterplane Area Twin Hull, or SWATH. As you can see from the picture of the *Frederic G. Creed* on the right, such boats have two submerged, torpedo-like hulls with hydrodynamic struts above them. So the drag mostly consists of laminar flow along these hulls, rather than drag from waves at the waterplane (there is no waterplane). This makes the hull a little slower in calm water, but much more stable in heavy seas SWATH.

While a monohull version was patented in 1880 and a SWATH design in 1946, the first ships were not built until the late 1960's and early 1970's. Although there are only about 50 worldwide, several are notable. For example, in 1992 Radisson built the *Diamond*, a 20,000 ton SWATH cruise ship. The design gives this 350-guest ship much less rolling motion than other cruise ships of similar size. While it looks somewhat like a catamaran above the water, below the water the *Diamond* features the same torpedo-like pontoons as the *Creed*.

In 1993, the public learned about the US Navy's *Sea Shadow*, a futuristic-looking A-Frame SWATH vessel which had previously only been operated at night. This 160-foot long stealth ship was manufactured by Lockheed-Martin in Redwood City, CA as a test platform for various technologies. It features a low radar signature, and while only capable of 14 knots can operate in extremely rough conditions.

24.6 Used Oil Platform

As we've mentioned, oil platforms are an excellent example of a pillared marine structure built to withstand the battering of the ocean. A number of people have suggested that rather than building some unique new structure, a group simply find an old oil platform and use it. While platforms are expensive to build, there is not much reason to charge a lot for an old one. In fact, the group could even be paid to dispose of it. There are thousands of oil platforms, and disposing of them safely is required and costly.

There are obviously both advantages and disadvantages to this technique. You get the building material much more cheaply. However, it's part of a structure that was not intended as a permanent residence, so considerable retrofitting will be necessary. Having exceeded its expected lifetime, there are likely to be structural concerns. For example, sacrificial coatings for biofouling will be worn through and sacrificial anodes will be dissolved. Further investigation by experienced marine engineers is necessary to determine whether this is a feasible option.

Chapter 25

Structure Design Issues

When evaluating these designs, there are several issues which come up frequently.

25.1 Fixed-Position vs. Free-Floating

Our main concern with fixed-locations is political insecurity. If some country claims that you don't have the right to be there, the colony is screwed, as relocating is likely to be very expensive. Colonists may not be willing to move there in the first place because of this risk. A free-floating design can always just move on. When you're talking about an expensive capital outlay (analogous to a house plus part ownership of the local utility company), the residents are going to find that level of security invaluable.

One could point out that the same pair of options is true today in normal countries, yet we usually choose to live in buildings rather than RVs because the political inflexibility is worth the extra room. But at sea, the tradeoffs are quite different, because the cost of moving buildings is so low. It is possible to have a house-like amount of space with car-like flexibility. Additionally, the potential dangers are more serious because of the uncertain political position of seasteads. Hence the fixed strategy is much less attractive.

Admittedly, there are advantages to a fixed location. One can discover and exploit local resources. Building costs will be cheaper. The colony can establish trade routes, and lay fiber optic lines. More long-term planning based on weather and local resources becomes possible. Pollution and bad waste practices are less likely. For these reasons, some groups may choose this route. However, we see political freedom as the fundamental motivation for seasteading, and freedom of movement is an important part of getting and keeping political freedom.

Add Vince's Migration stuff <http://seasteading.org/stay-in-touch/blog/3/2008/06/23/migration>

25.2 Breakwaters vs. Pillars

Besides the underwater solution, which we find unattractive, there are three basic ways to deal with waves. We can avoid them geographically (doldrums), stop them with breakwaters or rise above them with pillars. We'll focus here on comparing the latter two methods.

The crucial difference lies in how the two methods scale. A breakwater for ocean waves must be massive, it can't be built on a small scale. On the other hand, if you think of the breakwater as forming the perimeter of a circle with the colony inside, you can see that as the circle grows, the size of the breakwater grows with r , while the enclosed area grows with

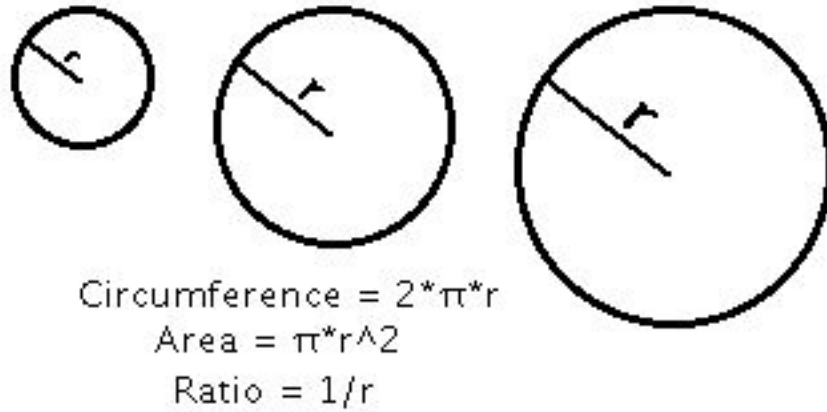

r^2 . This means that the ratio (how much breakwater is needed per unit area) falls with $1/r$, which is a huge economy of scale. In other words, a city 10 times larger will be 100 times cheaper per block. So for large colonies, breakwaters will be cheap, for tiny colonies they'll be tremendously expensive.

Pillars, on the other hand, have no such economy of scale. If you want to build another unit of area, you need the same amount of pillar as before. However, each individual pillar is fairly small, a small platform only needs one, and their cost is not out of reach of a new project. Thus pillars are well suited to our incremental approach. Still, one of the great things about the ocean is that there is plenty of room. So the high marginal cost of pillars is somewhat unfortunate, in that it makes using this space expensive.

This suggests to us that for small, initial seasteads, the pillar is a much better method. As the communities grow and become city-sized, they will reach a point where breakwaters become cost-effective. So while breakwaters are not suited to the initial stage which we're focusing on, they will be a crucial way to bring down costs later, and let us expand into all that cheap, unused real estate.

There are several other factors to note. Breakwaters can be used to obtain energy while damping waves. It is easiest to build them in fixed locations, which is problematic as described above. However it is possible to build a floating breakwater with a rigid connection to the colony, so the problem is avoidable.

Another worry is that by fencing off a fixed area, breakwaters may lead to a static geography. That is, if a single government has control of the area, they are a monopoly. Because of the economies of scale, residents can't just leave and start their own colony cheaply. This is not insoluble, but it is something to be aware of.

25.3 Modularity

The level of modularity in our designs varies greatly. Sailboat fleets, for example, are quite modular. Individual boats can leave or shuffle around as they wish. A big boat, on the other hand, is monolithic. Modularity is important for two reasons.

The first is dynamic geography. In order for DG to function, small groups of residents must be able to move their personal space. We think this is crucially important to making this new way of life better than the old. Hence we are skeptical of fixed-geography designs.

The second reason is to allow for incrementalism. A modular structure is likely to be amenable to an incremental approach where one module at a time is built. We think this approach is vital to actually making a floating city happen. Thus designs which require a large initial capital outlay do not seem promising.

25.4 New or Used

Just like a car buyer, seastealers must ponder this age-old conundrum: lay out the dough for something new, customized, with a long life ahead of it, or thriftily convert someone else's throwaway. While we tend towards the new approach, the issue is certainly not clear cut. A new, strange-looking seastead will feel to the world like a different way of life. This helps our political ends, as well as marketing appeal to prospective residents. It can be designed specifically for a permanent, comfortable, settled ocean life - which is not true of any existing structure. On the other hand, there are many large boats and oil platforms which are no longer useful for their original purpose, and can be bought quite cheaply considering the materials which have gone into them. Avoiding design work may lead to an imperfect solution, but at least it gets there sooner.

What tilts the balance for us is the surprisingly low cost of the structural portion of a seastead. (Renewable energy technologies are more expensive, but they would be needed in any design). Because designing and building a seastead is not that expensive, we see less reason to go the cheap route.

25.5 Protocol Suite

When talking about how we'd like to revolutionize the governing industry, we used the metaphor that we'd like government to be more like the internet industry than operating systems. One of the properties of the internet is that it is based on a variety of open standards which allow many diverse programs, companies, machines, and people to interoperate. We'd like seasteads to have this property also.

For example, the internet has a "protocol suite". As Wikipedia describes:

A protocol stack (sometimes communications stack) is a particular software implementation of a computer networking protocol suite. The terms are often used interchangeably. Strictly speaking, the suite is the definition of the protocols, and the stack is the software implementation of them.

Individual protocols within a suite are often designed with a single purpose in mind. This modularization makes design and evaluation easier. Because each protocol module usually communicates with two others, they are commonly imagined as layers in a stack of protocols. The lowest protocol always deals with "low-level", physical interaction of the hardware. Every higher layer adds more features. User applications usually deal only with the topmost layers (See also OSI model).

The same ideas apply to seasteads - we want to set up standards that various levels of groups of seasteads can follow, and allow individual structures and designers to innovate within that standards. For example, there will be a hardware definition for seastead attachment, specifying how to do structural attachment, how to do infrastructure attachment (network connections, perhaps power/water). We also need social protocols - What rules

govern each seastead? What are the default rules? How different can the rules be? How do you know when the ruleset has changed?

Later, in the Infrastructure-Government section, we suggest that all seasteads should have a liberal exit policy, so that we know all societies are freely chosen by their inhabitants. This can be viewed as a very high-level part of the protocol suite - and will require further definition to manage reputation, handle debts and outstanding criminal offenses, and so forth.

A good set of standards will allow both modularity and innovation, and will require a great deal of thought and refinement.

25.6 Structure Size

There is an obvious tradeoff in structure size: small structures are more modular, allowing location decisions and upgrades to be made at a small granularity. Larger structures have more economies of scale in manufacturing and operations, and thus will be cheaper per resident. The choice of spar vs. flat seastead will have a strong impact - the spar is a large overhead cost which will be cheaper if shared, whereas the small concrete boxes to support flat structures are likely to be very cheap at any size.

Until we know the cost curve, we can't determine a structure size, however there is one non-obvious consideration we'd like to mention. Seasteads are not merely structures to be engineered, they are homes to a community of people. And surprisingly, science has something to say about how big a community should be. Robin Dunbar hypothesized that part of the advantage of a big brain is that it allows you to have a larger social group. And he found evidence - within a species (such as primates, birds, reptiles, or fish) there is a very strong correlation between the logarithm of brain size and the logarithm of group size.

Based on human brain size, our optimal group should be about 150 people. And indeed, 100-150 is the size of hunter-gatherer tribes, military units, and the number of names in the average Rolodex of a modern city dweller. This is the largest group that is still small enough to keep track of reputation, favors granted and owed, and to all know each other. Groups at the high end of this scale require significant time devoted to social interaction, so 50-100 may be a more reasonable range. Some more recent evidence from social scientists who examine guilds in online role-playing games (MMORPGs) has confirmed this, see [[Allen200508][refs.html#Allen200508]].

So while individual spar-seasteads may not be economically feasible, we should be careful not to let structures get too large. Our vision is of seastead cities as dynamically-shifting entities composed of modular parts, so it's important for those parts to be small enough to hold a well-connected community, which can make good decisions about where it wants to fit in. If seasteads need to be larger than 150 people, we should consider subdividing them into 50-150 person sections.

25.7 Materials

Our preferred material is ferrocement, which is cement reinforced with iron rebar. However, a large number of previous ventures have proposed using an interesting material called seacrete. Our skepticism of this substance bears explaining.

For boats: material summary here.

{ Should we also explain other engr. mat. considerations in the marine environment? ie stainless, coatings, sacrificial anodes, plastics... }

Seacrete

Professor Wolf Hilbertz came up with the fascinating idea to create a material by submerging an electrified wire mesh in seawater. Minerals are drawn out of the water by the current, and a cement-like substance is slowly grown by accretion. Eric Lee [Lee] has done a very complete analysis of the use of seacrete as a marine construction material.

The number of 4.2 lbs / kWhr (1.9 kg/kWhr) cited for seacrete energy requirements in places like [Savage1992], if correct, would make it quite efficient. Unfortunately, this figure has two serious flaws. First, it is based on a single experiment [Hilbertz1979]. Second, it is off by a factor of 42 due to a computation error, as Eric Lee has demonstrated. Rather than integrating power over time to get energy, the power used was taken as the energy. The process took 42 hours, hence the error. In fact, at maximum theoretical efficiency the rate is only 1 kg/kWh, and practical efficiencies are much less than this. Hilbertz's published experiment produced only 0.046 kg/kWhr. At this rate, the energy alone costs well over an order of magnitude more than just buying cement.

There are additional problems. The major power loss is resistive heating of the forming seacrete. This is because the electricity has to get from the mesh through the seacrete to the seawater, and the seacrete is not a very good conductor. So of course the thicker the seacrete gets, the worse these losses will be. If you want to make structural walls for a sea colony, this is a definite problem. You can reduce resistance using a 3d wire mesh, but such meshes drastically increase the cost.

Because you are trying to replace such a cheap material (ferrocement), it doesn't take much to make seament uneconomical. In fact, there are some ways in which the ocean is the worst place to use seament. it's a place where energy is expensive and transportation is cheap. Using seacrete instead of importing cement is choosing to use energy instead of transportation - a poor tradeoff.

Marc Piolenc has suggested one interesting way of making seament worthwhile. You could set up a structure and some renewable energy scavenger in a remote place, then leave it for years to do its work. Even though the process is inefficient, you can replace efficiency with time if your source of energy is the kind which keeps on producing.

However attractive the idea of turning seawater into cement, seacrete appears to be a poor choice as a construction material. In practice, it is probably easier to use boring concrete and steel to build economical marine structures.

Ferrocement

{ how much should we say here? }

Our building material of choice is reinforced concrete, also known as ferrocement. It is a composite of two materials: steel rebar and concrete (which is made from cement and gravel). The steel has a very high tensile strength (it's hard to break by pulling), and the concrete has very high compressive strength (it's hard to crush). The combination is a material which is strong under many loads. Since it's mostly made out of rocks (which are plentiful) it's extremely cheap.

In the image you can see the framing system used for ferrocement construction. First a rebar mesh is built, then concrete can be troweled on, or forms can be built and the cement poured in. One advantage is that once a set of forms has been built, they can be re-used many times (this is true for fiberglass as well, but not steel). Also, since this is an extremely common building material, there are a huge number of ferrocement books, supplies, consultants, and contractors.



While it is not as popular as steel and fiberglass, ferrocement has a long history of use in the marine environment. It does require some special treatment, however. Over time, structural stresses create small cracks in cement. While this is not a problem on land, in the marine environment saltwater can seep in and corrode the rebar. For this reason, all surfaces will need to be carefully sealed. In our case, this means two layers of sealant. First will be Ashford formula, which makes it very difficult for water to penetrate the concrete. However, pressure over time will cause water to slowly seep through this, so an additional coat of epoxy will be used on the outer surface. Internal surfaces will only be exposed to humidity, not pressure or direct water, so the Ashford formula alone is sufficient.

An alternate possibility is to use a treatment like Xypex, which fills the pores and capillary tracts of concrete with impermeable crystals. Also, fibers can be added to the cement mix to add extra strength against cracking. Whatever system is used, it will be important to check occasionally to ensure that corrosion has not occurred. The easiest way to do this is with a commercial device which examines the electrical resistance of the rebar lattice.

[INTEGRATE THIS]: Kurt Horner writes: "I'm a structural engineer in California and sometimes I've done concrete construction near the ocean. The typical solution is to put an anti-corrosive additive into the concrete mix and buy epoxy-coated rebar. The coated bars

are about twice the price of regular bars, but this is a lot cheaper than coating the whole structure. This is especially true since the forces that will crack your concrete will also tend to crack your outer coating as well, rendering all that work somewhat pointless. That's not to say there isn't value in an outer coating, but rather than just papering over a problem, I'd recommend making the structure itself corrosion resistant.

Another way to stave off corrosion is to ensure that the exterior face of the structure is the compression face. This would entail making the exterior of the shaft a series of concave arcs (like a starburst in cross-section) rather than a simple tube. This would substantially reduce cracking on the exterior face."

Cement Lite

For interior, non-load-bearing surfaces, the full strength of ferrocement is not required. There are several alternate concrete formulations which are not suitable for holding up buildings, but feature the same durability and convenience. There are two basic ways of making them.

The first is to bulk up ordinary cement by adding foam. This can greatly reduce the cost per unit volume when strength is not a priority. One method is to add 1-20 pounds of powdered aluminum per ton of concrete to the mix. The aluminum foams up into gas, and can double the volume of the resulting product [TechTopics2000]. Another technique is to generate foam from soap such as dishwashing liquid. This can be done with a cheap homemade device and an air compressor, and the result also has about half the density of ordinary cement. Plans for such a device can be found at [Pelagic], and a picture of Wavyhill's experiments is shown at right.

The second method is to substitute a weaker, lighter, cheaper material for the gravel constituent of concrete. One example is "papercrete", which is a form of concrete using paper instead of gravel. The paper is mixed with sand, cement, and water to form a material which can withstand 300 psi and has an insulation value up to R-2. While papercrete holds its shape and is reasonably strong even when wet, it is not suitable for very wet environments (like exteriors or bathrooms) as it soaks up water quickly and dries slowly. When free paper trash is available, papercrete is even cheaper than ordinary unreinforced cement [MotherEarth2000].

Shotcrete

While concrete is normally poured into forms, it can also be sprayed into place using a mixture known as shotcrete. This can make construction much easier. For example, it is a key part of the construction technique used to build monolithic domes like the Eye Of The Storm mentioned earlier. These structures are cleverly made by inflating a large plastic form, building a rebar lattice, and then spraying on shotcrete. This avoids the need to build house-sized forms, since the inflated plastic provides the shape. As we'll describe later, similar techniques may help us build seasteads without a shipyard.

{ Should we describe MDI process in more detail here? What should we say? }

Chapter 26

Structures: Summary

While there is no single seasteed design that is correct for all situations, there are certainly some that are better than others. For individuals who already lead a sailing lifestyle, the sailboat fleet is an easy transition. By becoming gradually more self-sufficient and joining with other like-minded individuals, live-aboarders can become true ocean nomads through an incremental process.

For those starting from fresh, however, we think a platform-based approach is more promising. If a location can be found which is politically and economically feasible, and is protected from the waves (perhaps on the equator), simple concrete slabs will serve. For most locations, however, a spar platform will be required to reduce wave impact.

Eventually, as interest in seasteading grows, it will become cost effective to build huge breakwaters to create protected lagoons, allowing a slab-based floating city to be built anywhere.

One concept seasteed communities may want to explore is mixing various designs. For example, the community centerpiece might be a large spar platform, surrounded by a mixture of boats and freight containers. People could congregate in the larger facility for community activities, but actually sleep in individually owned and maintained freight container seasteeds or sailboats. The big structure would be an emergency shelter during storms. Containers could be hoisted up under the large platform to escape really bad surface conditions.

Part VI

Infrastructure

Chapter 27

Infra Intro

The necessities of life on a seasteed: food, water, power, transportation, and so forth, present special challenges. Fortunately most of these challenges have been met in other contexts, and we can build upon those solutions. Thanks to the growing movement towards resource conservation, there are lots of commercial products which use resources efficiently and are thus well-suited for seasteed life. Numerous books have been published on the topic of being self sufficient and living off the land. We used *Building for Self Sufficiency* by Robin Clarke [Clarke1976].

Seasteeds can choose their level of self-sufficiency based on factors like size, distance to land, initial capital available, and desired levels of trade and luxury. The initial seasteeds will probably be small and less self-sufficient. The variety of goods used in modern life is staggering, and it will simply not be feasible to make them all onboard. This is especially true because the ocean is a demanding environment, and it will be difficult to meet its challenges without some serious technology. Fortunately water transport is quite inexpensive, which makes importing many goods feasible. Thus we expect needs will be served by a continual series of compromises between local production and trade.

Different perspectives on self-sufficiency will yield very different choices. We've had libertarians and futurists scoff at the idea of growing their own food rather than just importing it, and we've had environmentalists who thought our ideas of self-sufficiency still depend way too much on the outside world. There is no "correct" solution, since the optimal seasteed for someone who sees local, do-it-yourself production as a plus is different from the optimal seasteed for someone who sees it as a minus. This may cause difficulties (and require compromises) on the first seasteed or two, at which point the groups will probably split. Our exploration of these technologies is biased by our particular viewpoint on a good level of compromise, but keep in mind that more or less trade are always available options.

Similarly, there are a wide variety of lifestyles in the world. The right seasteed for a billionaire will not be the right seasteed for a simplicity-oriented group. It would be difficult for us to cover this entire range. Still, some technologies are better suited to the ocean than others, and the differences between groups will mostly be a matter of degree. Catching rainfall is a good way to get water - but different groups will use very different amounts of water. So reporting on methods is useful to everyone.

To get actual figures and guide our research, we had to use some target market. We tried to use the first-world environmentalist movement whenever possible. Environmentalists because they are efficiency-oriented, as we will be. First-world because frankly, it's going to take that level of income to get the movement started. We think seasteading will be in reach

of many Americans at the beginning, but not the third world. This does not mean that our movement will not help poorer people. We believe that a good way to bring cutting-edge technology to everyone is to start out selling it to the high-end markets, then let experience and economies of scale bring down the price.

There are two major differences that must be dealt with as self sufficiency books are applied to seastead technology. First, even though the seastead is surrounded by water, fresh water is going to have to be tightly managed. We do not have the option of tapping into a stream or drilling a well to get unlimited supplies of fresh water. Fresh water management is covered in greater detail in the water section below. Second, surface area will be at a premium. Large meandering structures that occupy lots of space are not going to be viable in early seasteads.

We should comment that most of these self-sufficiency books start out with a preface that we will paraphrase as "humanity is running out of energy and resources; thus, we must change our evil high technology ways and go back to basic living off the land." These statements should not be taken at face value, because many of them are not supported by scientific evidence. For example, books written in the late seventies, during the energy crisis, predict that energy costs would only get worse - when in fact they got (and have remained) much better.

More generally, the inflation adjusted cost of energy and resources have continually declined when measured over periods of greater than ten years. Contrary to the theory that increased population causes a decrease in material wealth, the twentieth century saw a dramatic and consistent increase in population along with a dramatic and consistent increase in material wealth. A more balanced view of energy and resources can be found in *The True State of the Planet*, a compendium of papers written by ten environmental scientists who publish in peer reviewed journals [Bailey1995]. A number of the energy books we reference below suffer from the same basic flaw, however, once you get past the preface and first chapter of these various books, they tend to be pretty reasonable.

An interesting counter-argument is that while people on land may have plenty of energy and resources, seasteads will not. The doomsday-type analysis which assumes limited and expensive resources is actually more applicable to our environment than the one it was written for. (To be fair, it is also somewhat applicable to remote pieces of land). So even those seasteaders who agree with our skepticism about apocalyptic claims should not dismiss such viewpoints completely, as they are relevant to this new frontier.

Chapter 28

Power

{ Efficient refrigerators and freezers are available, and if they are heavily insulated, refrigeration can be maintained by running the cooler for an hour a day, about a 4% duty cycle [Norgrove1983, pp. 126-127]. }

{ heat water with solar: norgrove, pp. 119-120 }

Our seastead is going to need power, both for personal use and to support its infrastructure (food production, water purification, transportation). OTEC no good.

There are other workable alternatives that are both less capital intensive and more technologically mature, such as solar power, wind power, and wave power. (Nuclear power is yet another alternative, but it is extremely capital intensive and politically difficult; in terms of seasteading, nuclear power makes OTEC technology look easy.) Basically all of the alternative power sources have one problem in common - the power is intermittent. Solar power does not work at night, wind power does not work when the winds are calm, and wave power does not work when the seas are calm. The best solution to this problem is twofold: collect and store excess energy for times when power generation is not available, and use multiple energy scavenging technologies to smooth out the availability curve.



28.1 Energy Storage

For now, the most mature technology for storing energy appears to be electrochemical batteries. While they are expensive, the alternatives (flywheels, ultracapacitors, redox batteries, creating hydrogen to power fuel cells) are generally still experimental. However, redox batteries are rapidly approaching usefulness.

Electrochemical Batteries

Batteries are one of the most expensive parts of an electrical system. They don't store much energy per unit weight, and they don't last through many charge cycles:

“Batteries have always been an expensive and troublesome part of off-the-grid systems. Consider that a typical 6-volt storage battery has a gross capacity of 200 Amp-hours, equivalent to about 1 kWh of chemical energy, and costs nearly \$100. Thus, batteries cost about \$100/kWhr of gross capacity, not counting shipping costs. And shipping heavy batteries is costly. Moreover, not much more than 50 percent of the energy stored in a battery can be withdrawn without sulfating the plates and reducing its effectiveness. Batteries also have a limited lifetime. The Folkecenter for Renewable Energy estimates that batteries are good for about 2,000 cycles. (Batteries are still useable after 2,000 cycles, but they have reduced capacity.) If a battery discharges 50 percent of its gross capacity through 2,000 cycles, it will deliver about 1,000 kWh of net electrical energy over its operating lifetime. Thus battery storage alone costs more than \$0.10 per net kWh of useable energy in an off-the-grid system.”-[Gipe1999]

Ten cents / kWhr is around what power from the grid costs - and this is for battery storage alone! Because of this, we want to match up power supply with demand so that we need to store as little energy as possible. It will help to have needs with flexible timing, such as refrigeration or running reverse osmosis systems. These can be run whenever we're generating excess power. When other storage technologies become more reliable, they should be investigated. While batteries have their disadvantages, they are mature and robust and their cost is high but not prohibitive.

Vanadium Redox Batteries

The current forerunner to replace conventional batteries is the Vanadium Redox Battery developed by Professor Maria Skyllas-Kazacos and her team at the University of New South Wales, Australia [UNSW-VRB]. A redox battery consists of two chemical solutions which produce an electric potential when combined. When originally developed, they had the problem that the used combination of chemicals was toxic, caustic, and useless. The solution was to use a proton exchange membrane, like a fuel cell, to utilize the electrical potential without allowing the fluids to mix. Unfortunately, even with these membranes, some cross-contamination occurs.

The UNSW researches came up with a clever solution: using the same chemical for both halves of the cell, but in different electric states. Now cross-contamination just causes energy loss, not damage to the solution. Vanadium dissolved in sulfuric acid was the answer, although it took some effort to create a solution with a high enough concentration of vanadium to get a decent energy density. The advantages over conventional batteries include:

- Storage capacity limited only by tank size and amount of vanadium solution. So you can increase capacity just by getting more tanks and fluid.



- Number of charge/recharge cycles is theoretically infinite. In practice at least 16,000 (much higher than batteries).
- Energy storage and extraction are separate, so the capacity of either can be increased without affecting the other.
- Shelf life is indefinite, and energy does not leak during storage (unlike batteries, flywheels, capacitors...)
- High efficiency (80%-90%) because redox couples are electrochemically reversible.
- Fast charging, can be fully discharged with no adverse effects.
- Can be recharged by transferring fluid, as with gasoline engines, except the fluid is rechargeable. So, for example, if the seastead and its boats both used this technology, the boats could be refueled by pumping in new fluid, instead of slowly charging conventional batteries.

VRB has been used in actual, large-scale applications since about 1997 - it's not just theoretical. This includes a 450 kW / 1MWhr VRB system at the Kansai Electric Power Plant in Japan and a 25 Kw system used to store power from the wind power generator of Hokkaido Electric Power Co. It seems quite likely that the home power market will adopt VRB's when they become commercially available. The fuel cell will cost about \$200-\$500 per kilowatt and the electrolyte about \$40-\$60 per kilowatt-hour. The fuel cell membrane will last around 8-10 years, and the electrolyte can be re-used indefinitely [Skylas2004].

Hydrides

As described elsewhere, a seastead may wish to store hydrogen for use in cooking. Unfortunately, hydrogen in gas or liquid form is difficult to store. The liquid must be cooled to -423 degrees, and the gas must be compressed to very high pressures or you don't get much energy density. Being a small element, hydrogen is hard to contain. An interesting

alternative is to store hydrogen energy in solid or liquid hydrides, which release hydrogen gas when combined with water.

Since water is rather common, solids such as sodium hydride are quite dangerous in their natural form. Hence the invention of Powerballs - small pellets that are coated in plastic. The plastic is waterproof, so the hydride won't react accidentally. But simply cutting a ball when it is immersed in water produces large amounts of hydrogen. The energy density is about 6 times higher than compressed hydrogen gas at 3000 psi. The reaction's waste product is sodium hydroxide (NaOH). New powerballs can be created simply by heating the NaOH to create NaH, pelletizing it, and coating it in plastic [Powerball].

Another option is a liquid hydride such as sodium borohydride (NaBH₄). Since it only produces hydrogen in the presence of a catalyst, it is even safer and less likely to produce a runaway reaction. The reaction product, as with sodium hydride, can be used to re-generate the fuel. Millenium Cell is producing these systems and they are starting to be adopted in fuel-cell powered concept cars such as the PSA Peugeot Citroen and the Chrysler Town & Country Natrium [MilleniumCell].

The main issue for seasteaders is what facilities are necessary to re-generate these fuels. If large manufacturing plants are needed to create hydrides cost-effectively, they aren't good methods of energy storage. But if we can get a reasonably priced black box that takes energy and spent fuel and creates charged fuel, these might be good ways to store hydrogen. The technology is still a little too cutting edge for early seasteads.

Flywheels

Flywheels have gotten to the point where a few commercial models are available. However, they really don't store very much power compared to batteries, nowhere near enough to function as the reserve for a renewable energy system. Also, the seastead is a constantly moving environment (albeit a slow one), and unless the flywheel is on a very expensive mounting system, this movement will drain the stored rotational energy. Finally, since the seastead is not rigidly connected to the earth, spinning up a single flywheel would make us spin in the opposite direction! This could be fixed by using two flywheels with opposite spins, but it makes for an amusing mental image.

Supercapacitors

The new generation of supercapacitors feature significantly higher performance, and are moving rapidly towards being useful for power systems. Michio Okamura and JEOL have developed these nanogate-based supercapacitors, which have much higher current densities and lower leakage than traditional caps. They are used in a hybrid truck by Nissan Diesel Motor and a fuel-cell passenger car from Honda, both introduced in 2002. Capacitors have the advantage of unlimited charge/discharge cycles within their ~10-year lifetime. They can also discharge very rapidly (hence their use in automobiles).

However, capacitors cannot yet replace batteries because they don't store very much energy - only 1-10 Wh/kg (compare to lead-acid batteries 30 and NiCads 50). Also they leak over long periods of time. Currently they are best used in power systems to smooth out loads by acting as an energy buffer. Batteries keep them charged, and the caps handle energy spikes. While maintaining them takes extra energy, remember that the big problem with batteries is the limited number of charge/discharge cycles. This technique reduces the amount of cycling and can greatly increase battery lifetime [JETRO-Cap].



Gravity Battery

There is another energy storage system that has a slim chance of being useful. That is pumping sea water up to a tank on top during the day, and running it down to the ocean during the night. Power companies use such systems to even the load on the power grid, which is evidence that it is reasonably efficient. (They pump water uphill during the night they run when power demand is low, and run it down during the afternoon when power demand is high.) A seastead does have the advantage of a free source of mass (seawater), and height (if it's a spar design). Our major concern is the effect of moving weight upwards on structure stability.

Hydrogen

While hydrogen has its advantages for cooking, storing large amounts of it is impractical. It requires either a lot of storage space, or high pressure systems which are quite expensive.

28.2 How much do we need?

To calculate energy costs and design a seastead, we need an estimate of how much power we are going to use. As with other resources, we expect to be much thriftier than on land, so there is some guesswork involved in estimating the numbers. According to the California Energy Commission the average household in California uses 6.5 MWhrs/year [CEC_Solar]. A typical California Bay Area household uses 3.6 - 5.5 MWhrs/year [Yarris1994]. Chris Marnay's solar-powered house, which uses energy-efficient technology such as fluorescent lighting, uses 2-3 KWhrs/day for 2 people, which is 0.5 MWhrs/p/yr [Yarris1994]. Other solar-powered homes use 1-2 MWhrs/p/ yr.

There are many ways to economize on a seastead. Appliances will be energy efficient. The large concrete bulk of many seastead designs will act as insulation and a heat sink, moderating temperatures (which tend to be moderate on the ocean anyway). Water can be heated by the sun, and air conditioning can be done by pumping cold seawater up. Based on this, and the numbers above, we estimate energy usage on a seastead to be in the range of 0.5 - 2 MWhrs / p / year. This is 1.4 to 5.5 KWhrs / p / day.



28.3 How much can we make?

How much can we make?

There are a number of energy generation technologies, and creative minds can come up with many more fascinating and speculative ideas. The authors certainly have a few they'd like to experiment with. However, as usual, for initial seasteads we want to stick with mature options, which limits the possibilities.

Solar Power

There are an endless variety of ways to use solar energy - photovoltaic, solar heating, solar dynamic, etc. For electricity, we will focus on photovoltaic power, as it is the most mature. We'll also briefly discuss some other ways to use sunlight.

Photovoltaic Power

Photovoltaic (i.e. solar cells) technology was originally developed to supply power to satellites in outer space, a remote and hostile environment. It transforms sunlight directly into electricity. Currently, photovoltaic power can make economic sense for remote areas that do not have a connection to the electric power grid (like seasteading.) There is now a large body of practical experience with photovoltaic power that we can apply. The reference we used was *The New Solar Electric Home* by Joel Davidson [Davidson1987]; there are many other appropriate alternative books on the subject.

Photovoltaics have a number of disadvantages:

Cost Photovoltaic panels are expensive. They keep coming down in price, but they are still not cheap. **Efficiency** Even the most efficient photovoltaic cells have only recently started to achieve conversion efficiencies over 30% and these are horrendously expensive. The commercially available solar panels have conversion efficiencies in the 8-15% range. This relatively low energy conversion efficiency means you need more solar panels covering more area to achieve the desired level of power generation. **Battery Storage Required** Since the sun does not shine at night, there is no power coming in from the solar panels then.

So it is necessary to collect additional energy during the day and store it for night time use. The most storage method is to use a bank of batteries. The batteries are expensive and this increases costs. Solar Area Unlike other forms of power generation (wind, waves, generators), PV panels take solar area away from other needs such as greenhouses. This is especially bad because they use the sunlight which falls on them so inefficiently. However, as Edward Felton suggests, they can be cantilevered out from the platform, as solar panels are relatively light. This would also add to rainwater capture.

Despite these disadvantages, they have a proven track record for remote power generation, and have a place in a well-rounded power generation system for seasteads. Typical insolation is 1 KW/m², but only 13% of this is captured. There are about 1,750-2200 hours/year of full usable sunlight (at least on land - might be a little higher on the ocean with the low horizon). This gives about 0.25 MWhrs/m²/yr. The average PV system costs about \$10,000/kW [RingEco] of installed capacity. Using that 1750-2250 number again, we see that a kW generates around 2 MWhrs/year. So PV systems are about \$5,000/person, and around \$2,000 for a kWhr per day.

Direct Solar

One thing you might have noticed when reading about PV is just how inefficient it is at converting sunlight to electricity (about 13%). This is especially annoying because it is so expensive. For this reason, it's usually better (when possible) to use sunlight directly. This makes life more complicated than just doing everything with electricity, but in an environment of limited energy resources, it's still a win.

There's no clever way to run your computer directly from sunlight without using electricity. But a large portion of home power usage is for heating: both spaces and water. As anyone who has walked across pavement in bare feet on a sunny day knows, all you have to do to turn something into a sunlight-to-heat conversion device is paint it black. Even simple solar water heaters are about 30% efficient, and cheap compared to PV panels. More complex designs are more efficient.

There are many other applications of direct solar, such as water distillation, space heating, laundry and dish drying. it's unclear just how many we'll use, since it depends on the energy available from other sources, how much money is available to spend on power systems, and so forth. Space heating, water heating and solar distillation are the main applications that we think will be commonly used.

Wind Power

Like solar power, wind power is a fairly mature technology that has been around for quite a while. The references we used for wind power were *Harnessing the Wind for Home Energy* by Dermot McGuigan [McGuigan1978]; and *Wind Power Basics* [Gipe1999]. As with photovoltaics, there are numerous appropriate alternative books on the subject. Again, most of these books start out with a statement of the form 'we are running out of energy' that should be discounted.

Wind power has two major advantage over photovoltaic generation. The first is 24-hour a day power extraction is possible. While there are times when the wind dies down, seasteads will likely spend much of their time in places where the "trade winds" blow continuously. Wind energy rises as the cube of wind velocity, so a steadier wind at the same average velocity provides significantly less energy than a variable wind. However, there are big benefits to consistent winds, such as reduced dependence on costly storage systems. The



second is that raised wind turbines have essentially zero footprint and will not reduce top-deck area, which is needed for food production. Winds are stronger the higher you go above flat terrain, which is great for our seasteads that tower above the ocean. Experiments have shown that to raise a turbine from 18m to 30m increases power by 25%.

International Wind Energy Map

(Map prepared by NREL, [click for larger image](#))

Wind turbines can be a bit loud, and elevating them out of the way involves guy wires - more difficult on a small seastead platform than land. Another disadvantage is that some of the wind's energy pushes the seastead. Some experiments will need to be performed with wind power to figure out how severe the wind pushing problem is. Fortunately wind and current directions are not usually parallel (trade winds are perpendicular), otherwise we would lose further velocity because drifting with the current would reduce the apparent wind velocity. Given the large size of a seastead and the small area likely to be used for wind turbines, this pushing should not be much of a problem.

{There is tons of data on wind speed available from the NOAA's NDBC data buoys. We can get data from there and estimate how much power is available.} The energy produced by wind turbines depend a great deal on wind velocity (because of the cube law), thus it is difficult to estimate how much power will be produced without knowing the details of local conditions. It looks like to generate 1 MWhr/year, we need about a 600 watt turbine. Small wind systems seem to cost around \$3K / Kw, so that's \$1800 / person. A large system for a decent sized seastead might be only half that price. Wind power has higher maintenance costs than solar, ie (for large power operators) 1.5 cents/KWhr, which is \$14/p/ yr for us.

The seastead is free to use any form of turbine; they all work with varying degrees of efficiency. One design with interesting DIY possibilities is the Savonius rotor, sometimes referred to as an oil drum rotor. A cross section of a Savonius rotor, which consists of two half-cylinders, is shown below:

The Savonius rotor is a very inefficient design, which means more weight to be lofted. However, it also looks like it's very easy to fabricate, since many Savonius rotors are manufactured out of old oil drums. Cut off the top and bottom, chop it in half, weld two of the

Figure 28.1:

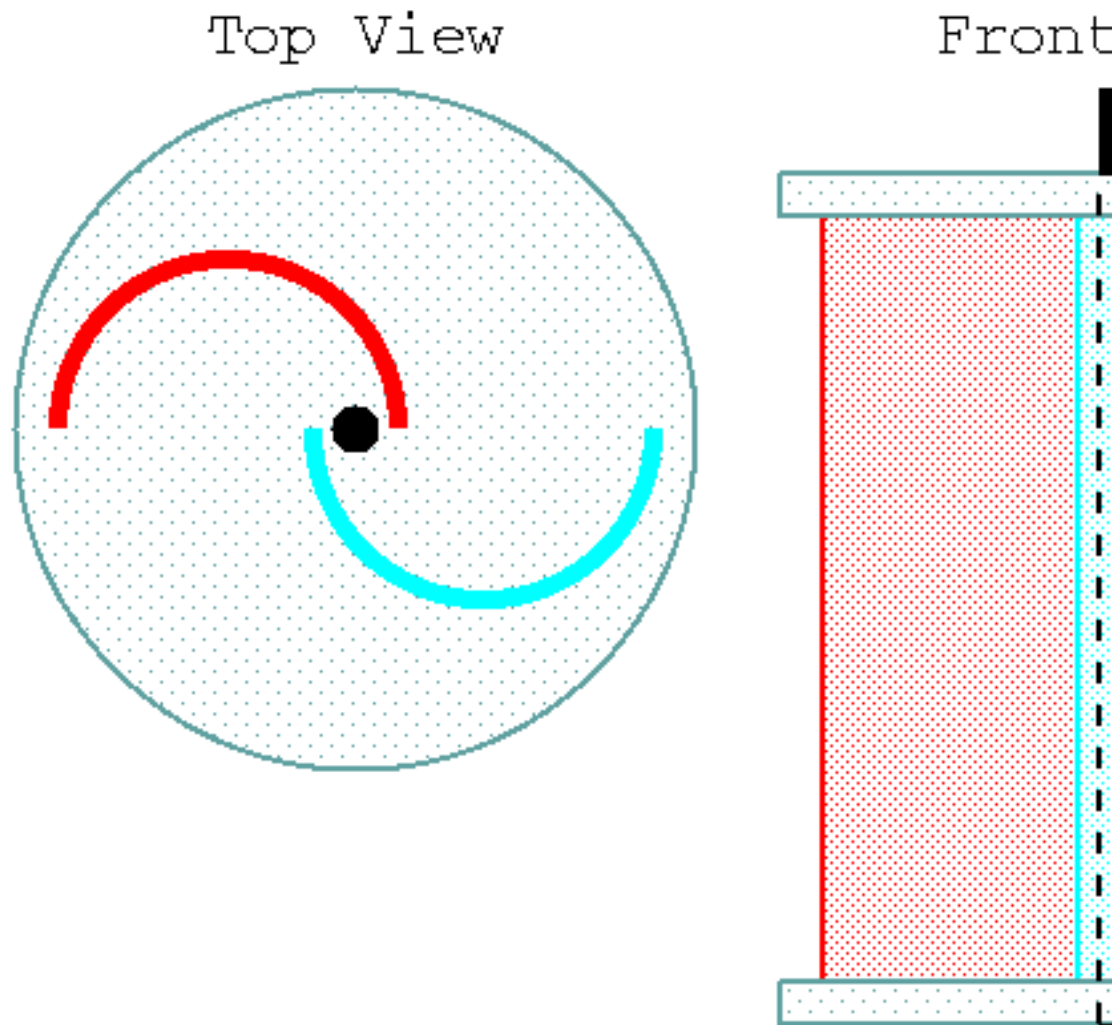

Savonius Rotor

edges together, and you have a rotor. Ultimately, what matters is not wind mill efficiency, but cost times efficiency. If cost is sufficiently low, additional power is obtained by simply erecting additional wind mills. Conveniently, Savonius rotors can be stacked on top of one another.

Fuel-Powered Generator

Renewable energy generators are great for self-sufficiency and long time-horizons. Once a seastead has installed enough PV panels and wind turbines, it does not need to import energy. However, renewable methods have some disadvantages. They are currently pretty expensive, they can't produce big spikes of power for occasional high demand, and they don't generate power constantly. Generators, which burn fuel to create electricity, address all of these issues. They can be run at any time, are cheap to operate, produce a lot of energy, and fuel (unlike a battery) is a dense form of energy storage with an excellent shelf life.

In general, fuel-powered generators seem best suited as a backup power source. For major power needs (welding) and during windless nights with calm seas, there will be little choice but to fire them up or do without. However, there are some specialized groups that may depend solely on generators, and others that will avoid them entirely. Low-budget seastealers may want electricity, yet not be able to afford to buy renewable equipment with its long payback period. Seastealers with particularly low transportation costs or low local renewable energy levels may also wish to stick with generators. On the other hand, environmentally-minded groups who don't like generating greenhouse gasses might avoid them all together.

Burning diesel or biodiesel in a conventional generator is extremely price-effective. At \$1.40/gal in the US, and about 12 kWhs produced per gallon of diesel, electricity generated from diesel costs \$0.12/kWh in fuel. Biodiesel can be cheaper if a free source of used vegetable oil is found. Maintenance costs are very low (\$0.004 - \$0.010 / kWh) [Kozlowski2002]. Transportation costs are the major unknown variable. Bulk container shipping rates would have essentially no impact on the cost per kWhr, but until seasteads are major container ports, shipping to them will be a lot more expensive.

We should note that these figures don't count all the energy produced as heat from the generator. This heat can be recaptured from the exhaust gasses through air-water heat exchangers and used for water and space heating. When heat as well as electricity is useful, generators become even more cost-effective.

Generators are pretty cheap per installed kilowatt. For example, the Kubota GL6500S diesel engine produces 6Kw for \$4300. That's 144 KWhrs/day, or about \$30/KW/hr/day of installed generating capacity. At 3 KWhrs/person/day, that would be \$90/person of installed generating capacity. Not bad at all, and the price will be even lower for larger units.

While generators aren't the only place we'll use fuel, this is a good place to discuss what's available.

Gasoline

Gasoline should never be used on a seastead unless absolutely necessary. It is volatile, evaporating at temperatures above -45 (deg) Celsius (its "flash point"). This means that at normal earth temperatures, it is constantly emitting flammable vapor, which is quite



dangerous. it's also extremely toxic, as its decay products are benzene and a bunch of other nasty chemicals.

Diesel

Diesel is a much mellower fuel, only vaporizing at temperatures above +50 (deg) Celsius, which are unlikely to be found in a seastead. The higher a fuel's flash point, the safer it is to store and handle. Diesel engines have a much simpler design, thus they require much less service and are more durable. Their exhaust also has many fewer toxic emissions than gasoline. They are much more efficient at turning fuel into electricity. Diesel engines are more expensive, but they are well worth it.

Biodiesel is harder to find internationally than diesel. It burns more cleanly, and is easy to make from vegetable oil. It has an even higher flash point than normal diesel. It is possible that a seastead could buy large amounts of used vegetable oil cheaply and make biodiesel for less than conventional diesel. Growing it is not likely to be practical due to surface area limitations.

Hydrogen

Hydrogen is a simple form of stored fuel, and quite safe (despite popular misconceptions). The bright flames from the Hindenburg zeppelin came from the lacquered covering, as most of the hydrogen escaped and did not burn [APS2000]. Hydrogen is lighter than air and disperses easily, so it does not accumulate in enclosed spaces. It is non-toxic and its combustion produces only water vapor as a byproduct. It is completely renewable, since we can make it from water via electrolysis, although this process currently has an efficiency of only 66% or so.

We can store small amounts of hydrogen gas fairly easily, although large amounts must be stored at high pressures, which is more difficult. An interesting alternative is to use solid or liquid hydrides. While hydrogen can be burned in generators to create electricity, it is not the best battery for an electrical system because of the storage difficulties and

inefficiencies. Where hydrogen shines is for very energy-intensive tasks such as cooking. Appliances designed for natural gas and propane, which are inexpensive and widely available, can be easily modified to use hydrogen. And unlike natural gas and propane, we can make hydrogen ourselves.

Propane

Propane is a cheap fuel, even if imported. We may well use it for coaststead. It can be used for cooking, heating, or even to run refrigeration units. There are two problems with propane. First it is heavier than air and will sink into the spar or other confined space, which is extremely dangerous, although precautions can be taken to reduce this risk. This is why most boats do not use propane. Second, it has to be imported, and thus reduces our self-sufficiency. Despite these, it may be the right fuel for coaststead because of its wide availability.

Wave Power

Waves can be looked at as a very concentrated form of wind power (which is in itself a modified form of solar power). Its advantages include:

- Waves have about 1000 times the kinetic energy of wind, so smaller devices can produce more power.
- The ocean is rarely in a dead calm (while even the trade winds die down in the morning and night).
- Extracting the power is quieter than wind turbines.

There are disadvantages as well. Despite rarely ceasing completely, waves are much more variable than wind - available energy seems to depend on the 5th power of wind speed [WA_Wave] (while wind energy only depends on the 3rd power). Being an immature technology, wave energy is currently more expensive than other methods like burning fossil fuels - at least for conventional locations. In the ocean, this may not be the case (further research will be necessary).

There are literally hundreds of different ways of extracting energy from the waves. As one example, an Australian renewable energy company called Energetech has developed a system which uses a parabolic wall to focus wave energy. At the focus of the parabola is an oscillating water column chamber, where the water rises and falls at several times the wave amplitude (due to focusing). This water movement causes air movement past a turbine, which is computer-controlled to optimize energy conversion. A 500 MWh/yr installation will begin running in the summer of 2005 off the coast of Australia, and a similar installation will begin operating in 2006 in Rhode Island [Energetech].

We think there's a good chance that wave power will become the primary source of seastead energy. However, at the beginning we want to minimize novelty and experimentation. PV panels, wind turbines, and diesel generators are much easier to buy, set up, use, and maintain. We are not aware of any small-scale, commercially available wave-powered generators which don't require mooring or coastlines (although we'd love to hear of one!). So we think wave power is best postponed until it can be researched from a functioning seastead (perhaps the baystead prototype). Still, this concentrated form of energy may well be an important part of making larger conglomerations and industrial areas feasible.

Many of these methods are coast-based, mooring-based, or capital intensive, which stems naturally from their origin in government-funded research. Still, there are a few which are

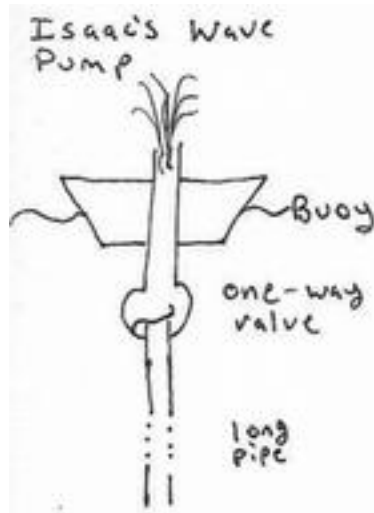

probably suitable for a seastead. For one thing, we may be able to adapt systems which need to be moored to the seafloor by mooring them to our flotation chamber. It will resist vertical motion, which is what these devices require. However, this adds extra stresses to the structure, so we'll present two other options.

Wave Pump

Our favorite system for DIY power in deep ocean is the Isaac's (or Scripps-FOR) Wave Pump. It was invented by a professor at the Scripps Oceanographic Institute in San Diego named John Isaacs, whose constant stream of ideas was rumored to have nourished the entire institution. The design is elegant and well suited to a seastead as it contains only three basic elements: a buoy, a one-way valve, and a long pipe.

Middle: Wave pump testing off La Jolla, CA produces a stream 4m in light seas (photo S. Suess). Right: US Marine helicopter assisting wave pump deployment off Kaneohe Bay, Hawaii (photo US Navy). From [Behrman1992, picture section], pictures (c)1992 American Geophysical Union, Reproduced by permission of American Geophysical Union

As a wave crest lifts the buoy, the pressure of the water in the pipe closes the valve. The result is that the slug of water inside the pipe is lifted along with the pipe and buoy. When the buoy reaches the top of the wave and begins descending into a trough, the water keeps going, opening the flapper valve and squirting out the top of the apparatus. Power is proportional to the volume of the water being lifted, which means that a longer pipe gives more energy. In essence, the pump acts to amplify the wave head, with a gain dependent on its length. A pressure reservoir is added to smooth out the flow, and a hydroelectric turbine to transform the pressure into electricity [Behrman1992].

The wave pump has only been tested on the ocean a few times, most notably at Kaneohe Bay in Hawaii [Wick1977]. While it has pumped plenty of water, it has not yet been demonstrated to be practical for electricity generation. Still, it is quite scaleable, has a small footprint, and uses few parts. Additionally, as a side effect of generating power it creates an upwelling which brings nutrient-rich water to the surface. In fact, it has proposed that it may be worth building a wave pump for this reason alone [Avery1992]. This method seems

almost too good to be true (and perhaps it is). Part of the reason may be that it functions best in deep water, and bringing power back to land is expensive. One downside of the pump is that it must be able to survive large storms.

The pump has some extra advantages compared to other wave power systems. As reader Kirk points out, it provides cool water, which can be used for air conditioning, for condensing fresh water from greenhouse air, and any other cooling needs. The longer the pipe, the cooler the water, and the more electricity, so there will be some "economies of length".

Russell Rectifier

This device is described in *Ocean Wave Energy Conversion* by Michael McCormick [McCormick1981, pp. 110-117]. If you have had any experience with electronic circuitry, the Russell rectifier is the hydraulic equivalent of a two diode electronic rectification circuit. An input is placed at the height of the wave crests, and is constantly fed by them. An output is placed at the height of the wave troughs, and spills water into them. In between, the pressure head formed drives a turbine. While this is not particularly efficient, the Russell rectifier looks like it will be quite inexpensive to construct. It consists of a couple of simple reservoirs, some piping, some one way valves and a low pressure water turbine.

Fuel From Crops

Another potential way to get energy is to grow crops, either for vegetable oil (which can be converted to biodiesel), or for sugar, which can be fermented and then distilled to yield alcohol. Hydroponic potatoes have high yields and are rich in starch. Biodiesel has the great advantage that it can be used with existing diesel generators and motors. However, these processes are quite inefficient, and are best left to land where area is cheap.

An alternate possibility is to use algae. As with *Spirulina* for protein production, algae waste much less resources in producing their output. NREL estimates that algae can produce 15,000 gallons/acre/year of biodiesel [UNHBiodiesel]. Again, even if algae are more efficient, such land-intensive industries are best suited to where land is cheap. However, it is worth noting that while conventional terra firma is expensive on the ocean, terra aqua {?aqua firma?} is cheap and plentiful. If algae can be farmed on the ocean's surface, the comparative disadvantage of seasteads becomes a comparative advantage, and this could prove a profitable industry.

Until such technologies are developed, we suspect that initial seasteads will need their limited growing space for food, and that other forms of energy generation will prove more useful. A seastead is much more likely to import fuel than to grow it.

OTEC

Several potential ventures [Savage1992, Celestopea, Nexus] have planned to use a technology called Ocean Thermal Electric Conversion to obtain power. This method uses the temperature differential between the warm water at the ocean's surface and the cool water in its depths. Energy can be derived from any such temperature difference.

There are some huge advantages to OTEC technology:

- It works 24/7, which reduces the need for expensive energy storage devices.
- It produces fresh (desalinated) water as a side effect of its operation.

Figure 28.2:

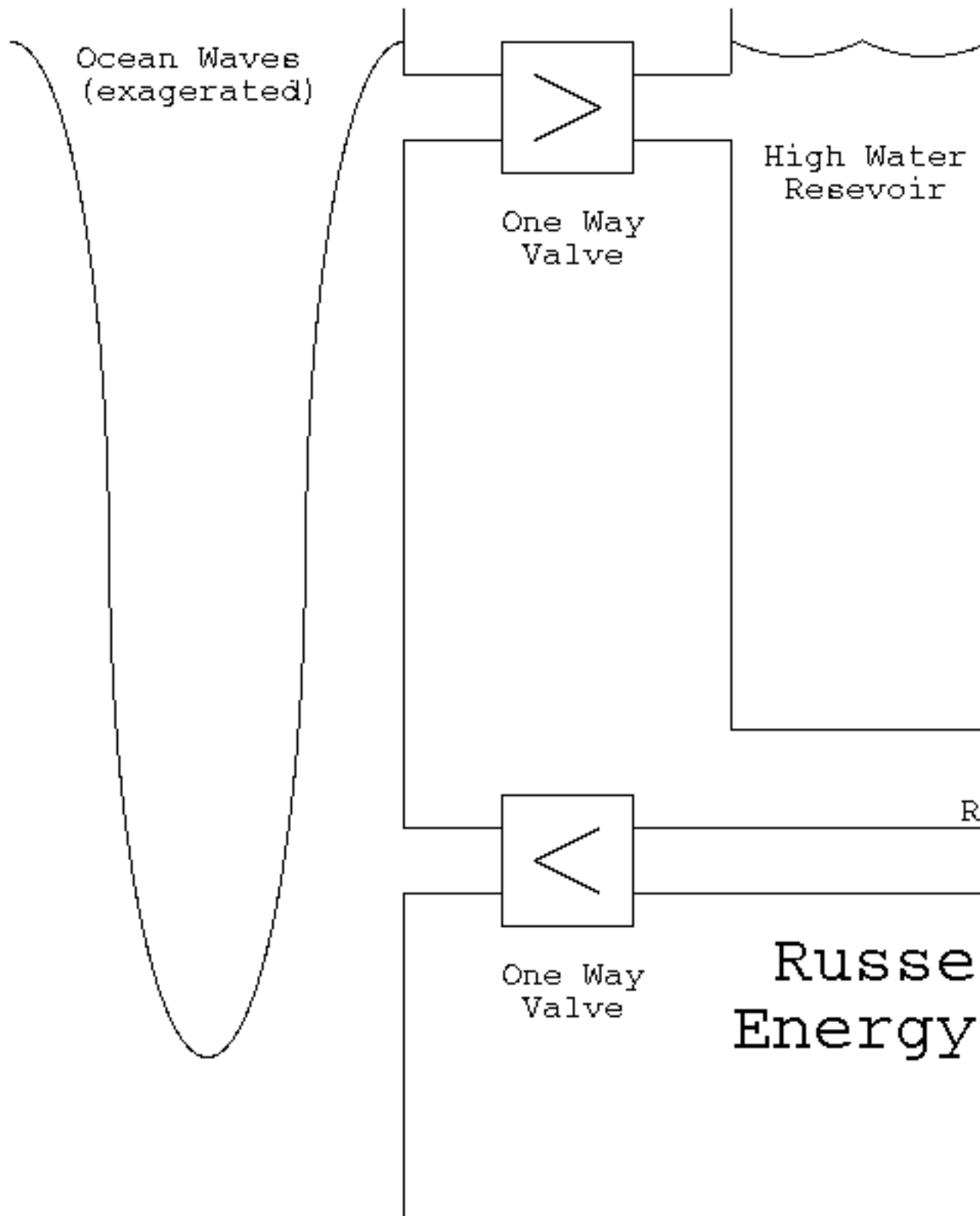

- The amount of energy available is enormous.
- Like the Isaac's Pump, it brings nutrient rich water from the deep ocean to the surface, which can serve as the input to a mariculture system.

Sadly, it will be quite awhile before seasteams can take advantage of this technology. Because it takes a large temperature difference to obtain much energy, pipes must reach deep below the ocean's surface. Continuously pumping fluid through these pipes uses up so much energy that only a large OTEC plant can generate a net positive amount of power. (There are huge fixed costs to be amortized over the variable gains). An OTEC plant with reasonable cost characteristics would probably cost over a hundred million dollars. A cost comparison with nuclear power can be found in [\[\[EnergyIslandCost\]\[EnergyIslandCost\]\]](#).

Additionally, OTEC is a new and unproven technology. Only a few plants have been made, generally funded by governments for research purposes [\[NREL-OTEC\]](#). Even though private companies are working on more efficient designs, they are still very expensive [\[SeaSolar\]](#).

OTEC is very promising for the distant future when floating cities are large enough to need half-billion-dollar power plants, but since the technology does not scale down, it's just not suited for the small communities which we'll have at the beginning.

A reader comments:

Chris Moore: However, I am confused about your attitude about the technologies of OTEC and DOWA. You stated that virtually no OTEC power plants have been run at net power. However, Dr. Liu, a professor of civil and environmental engineering at the University of Hawaii, states otherwise. In fact, in 1979 a Mini-OTEC (on a barge) off the coast of Hawaii was operating at gross 50kw of power and net 18kw of power. Again, in 1981 a Japanese consortium built a land based closed cycle ammonia based OTEC in Naurau. An OTEC powerplant ran for 6 years in Hawaii netting 103kw of power.

There are significant problems with the technology, though. The main problem obviously the energy, infrastructure, and operating expenses required for these plants to pump water from the deep. Jesus it is staggering the equipment and energy needed to do this pumping! The dollar/kw is tremendous.

You may already be aware of this lecture series... but I don't see why Dr. Liu's very relevant research has not perked much interest in your book. In fact, you discredit the whole idea, while it could be just the emerging technology that funds the whole big bastard. I urge you to reevalutate his findings.

Sincerely, Chris Moore

Dr.Liu, however, has designed and experimented for years with a 4 meter diameter 300m deep wave pump off the coast of Oahu. His system pulls 1 cubic meter/second from 300m below. It then simply bubbles up and spills out into the ocean. He was studying flow rates and structural designs, but became more interested in the effects he saw on the water around his bouy and the effects of the nutrient-rich plume being generated.

The obvious potential here lies with the fact that ocean waves an unexhaustible energy source is doing all the work. The effeciency of combining this wave pump with an OTE converter! Dr. Liu goes into specifics. "It was estimated that approximately 4 cu.m/s of warm seawater(25 C) and 2 cu.m/s of cold seawater at (5 C) are needed by a OTEC to produce 1MW net electricity."

Chris Moore: Actually, Dr. Liu believes that, although energy production is profitable, the real asset lies in the nutrient rich water. He estimates that

a combined OTEC mariculture system that receives 3.76 cu.m/s can generate 1 MW of power valued at 6 cents a kw/h = \$473,000; but more importantly you can generate 1693 tons of shellfish valued at \$1,564,200. Seafood is a very lucrative commodity. The potential here is to mari-cultivate the open ocean where aquatic life is scarce because of nutrient depletion.

(Add info about resurgence of OTEC . \$600K DOE grant in US. Claims of someone getting funding for a big OTEC plant).

28.4 Power Conclusion

What happens if you have a bunch of cloudy low wind days (i. e. reduced solar, wind and wave power?) Well, you either put up with the power failure (i.e. break out the candles) or you fire up your fossil fuel backup generator; these are the exact same options that most people on land face when their power grid power fails. An integrated system of photovoltaic, wind, and wave power with battery storage and a fossil fuel generator should provide a very high level of power availability to the seastead. Such an integrated system should still cost substantially less than an OTEC system and have the advantage of maturity.

??? If not, we will probably have uneven power availability. During the day and during windy periods of time will be when we run the appliances that need the heavy juice. During energy shortages, we'll just back off and use what we've got for critical stuff.

Chapter 29

Water

{Patri - check whether PV/RO or distillation makes more water from a given amount of solar area.}

Despite being in the middle of an ocean, obtaining and retaining an adequate supply of fresh water is going to require some careful thought and implementation. There will be a continual loss of fresh water due to evaporation and other factors, so fresh water needs to be replenished. There are several possibilities for water replenishment - rain water collection, distilling sea water into fresh water, reverse osmosis of sea water into fresh water, and importing fresh water. Of these, importing fresh water seems the least practical and rain water collection seems the most practical.

29.1 How Much Water Do We Need?

Water use on a seastead can be roughly divided into two major components: personal use and food production.

Water Requirements for Personal Use

The book *Blueprint For Paradise* by Russ Norgrove is (despite the title) an exceedingly realistic book about living on small islands. Norgrove suggests a water ration of 100-200 L/p/day (35K-70K L/p/yr) [Norgrove1983, p. 103-104], which we think is much too high. According to Neumeyer Neumeyer1982, avg. household water use in the United States is 190 L/p/day (69K L/p/yr). A more recent source suggests use of 280 L/p/day (102K L/p/yr) in a typical single family home with no water-conserving fixtures [Water1999].

Fortunately, people on a seastead can easily use far less water than the average american. Folks living aboard their sailboats sure aren't using 150 liters of freshwater per person per day! Hill says:

People seem to use vastly differing amounts of water, some struggling on a gallon per day and others thriving on two pints. Pete and I manage quite successfully on between five and seven gallons (19-26 L) per week between us, which amounts to a maximum of 4 pints (1.9L) per person per day. To achieve this, we don't seem to try very hard, but we do have water-saving methods,



which make it easy and painless to be economical with our water use. [Hill1993, p. 53]

This figure of 1.9 L/p/day is quite low, and we doubt seasteaders will be that frugal (unless they must). Rose suggests 7-20 L/p/day (2500-7300 L/p/yr) [Rose1979, p. 120] as a more typical level of water consumption. Unsurprisingly, these are all much less than on land. Requirements for drinking are 2L/p/day, more in hot environments or with strenuous exercise. Another source suggests 2.3 to 4.2 L/p/day as the minimum for drinking and 9 L/p/day as the minimum for hygiene, totalling 11 - 13 L/p/day [Eckart1996]. Jewell's closed-loop space station allocates 30 L/p/day for all uses [Jewell2001]. The ITDG suggests that in developing countries, the minimum requirement for personal use is 20 L/p/day, but that some functions can be performed with saltwater and a typical requirement for distilled water is 5 L/p/day.

As with most aspects of seasteading, there will be a trade-off between cost and convenience. As we'll see, obtaining the basic drinking requirements of 4 L/p/day will be trivial using any of our methods of water production. The quantities of water used on land (200-300 L/p/day) are feasible only in very rainy areas or at great expense. The individual preferences of seasteaders will determine what point in this range is selected. We'll use 5, 15, and 100 L/p/day as our points of analysis.

Water Requirements for Food Production

{ Better numbers would be nice. We have not found them. Empirical testing on baystead may be necessary. }

An analysis of a hydroponic gardening system as part of a proposed space station design suggests 720 L/p/day (although it also gives 30 L/p/day for personal use, which we feel is high) [Jewell2001]. However, this design has less need to be efficient because it is a closed loop (all water and biomass is recycled, so if they use too much water they still recover it).

Water usage for traditional crops is around 6-15 megaliters / hectare / year (rainwater and irrigation). This is 1.6 - 4.1 L/m²/day. Our crops will be much denser, increasing water requirements per unit area. However, they will also be grown hydroponically in greenhouses, decreasing water requirements per unit crop produced.

Non-greenhouse hydroponics: 2-4 L/m²/day[Bradley2001]. This should be an upper-bound on our water requirements, since greenhouses are more efficient. NIMSS reports an unpublished study in which 13.9 liters water were used per 1 kg of tomatoes in the field. In a greenhouse, only 2.4liters/kg were used. So the greenhouse is much more efficient, but since it's denser, this doesn't tell us about water / unit area.

Theoretically, the only water losses from a food production system are evaporation, run-off and water contained in material which is removed (for consumption or composting). Run-off is eliminated in hydroponics, and water in material eaten goes to good use. Evapotranspiration is thus the dominating factor for efficiency. There are ways to reduce it [MBR, Ch. 29]. For example, using a greenhouse traps the water vapor in an enclosed space. Still, we must remember that "sweating" is an important method of cooling for plants. If the air becomes saturated with water, the plants will not be able to cool themselves, as well as being more vulnerable to fungal diseases. We could dehumidify the air without losing water by passing the air from the greenhouse through a condenser (perhaps using seawater for cooling), and capturing the resulting water. Essentially, this is treating a greenhouse like a solar still. We see a pretty good chance that this technique will be desirable.

Aquaculture will likely use saltwater species, and so won't contribute to fresh water requirements. Small animals, such as chickens, should have modest water requirements (drinking only), although whatever we feed them will have had water needs as well.

These numbers are very approximate, so we'll use a large range of 20, 85, and 500 L/p/day as water requirements for food production. This leads to total water usage checkpoints of 25, 100, and 600 L/p/day.

Economizing on Water Use

Water that does not get used does not need to be supplied. It should not be difficult for seasteaders to economize on water use:

- 28% of domestic water consumption is used for toilets [Water1999], which can be eliminated by using toilets which flush with salt water, or better yet, composting toilets which use no water and save the valuable nutrients.
- Seasteads will probably take their cue from the environmentalist movement and utilize multiple water systems, such as drinking water, grey water, black water, and so forth. An excellent discussion of designing net-positive-benefit greywater systems can be found at graywater.net
- Using greenhouses should greatly reduce our evaporative losses, by keeping moist air trapped inside the growing space.
- Hydroponics claims to require 1/25th as much water as conventional cultivation (this may include greenhouse gains).



- Residents can use misting showers.
- Water minimization technology for many common uses (dishwashers, washing machines) is widely available.
- As rain varies seasonally, water usage can vary as well, being used at high levels during the rainy season and low levels during the dry season. This effect can be created with quotas or with market-based systems such as adjusting the price of water.

29.2 How Much Water Can We Get?

"I mix my water myself. Two parts H, one part O. I don't trust anybody!" - Steven Wright

(Insert Watermaker Weekly Research Project results)

Rain

Norgrove says that roof-based water collection is eminently practical - a reasonably large house roof, on most islands, will supply enough water for the residents [Norgrove1983, p. 103-104]. Assuming 30% loss of water, 1 m² of roof will yield 7 L/cm of rain. Average precipitation over the ocean is about 3mm/day, or 1.1m/year, with much less seasonal variation than on land (which is an advantage) [ERA40]. It is unclear from our source how much regional variation there is. So for every square meter of rain collection area, we get about 750 L/yr or 2.1 L/day:

Checkpoint (L/p/day) 25 100 600

Rain collection area (m²/p) 12 48 286

Our current designs have about 30 - 50 m²/person. The highest checkpoint would represent a drastic decrease in our planned population density to achieve from rainfall alone. But if most of the top deck can collect rainwater, we can just about achieve the middle checkpoint without alternate methods. It is not hard to make the exterior of a greenhouse collect water, and much of the top deck will be covered with greenhouses. If the top deck is covered with a skin, this does the job easily as well. Or tarps could be raised during rain to collect water, and would serve the additional function of sheltering the top deck. Any rainwater collection device should let the first few minutes of catchment drain, to rinse off salt spray and small debris.

Areas that do not catch rainwater can be compensated for with water production or collection area elsewhere. We could build floating rainwater collection modules, since water collection apparatus (a big tarp) is light, cheap, and simple. This lets us cheaply use more area. One problem with this is that lightweight water collection (tarps) don't deal well with high winds, and rain often comes with winds. Also if they are low, they will catch some salt spray. We may be able to spread a tarp below the platform and above the waves to capture rain (as long as it falls at an angle), although it will catch spray as well. Tarps could also be projected out sideways from the decks, since they are very light.

If the seastead is parked in area that does not get regular rain storms, or it is the dry season, an alternative method of fresh water replenishment is needed. Either sea water distillation or reverse osmosis will work. Both methods require significant amounts of power, in the form of sunlight for distillation and electricity for reverse osmosis.

Solar Distillation

We can get water without rain using a solar still to purify seawater by evaporation. Solar stills have been used since at least the 16th century, and mass-produced since WWII, when 200,000 inflatable stills were made for the US Navy [ITDGStill]. Thus it is fair to say that they are a mature technology. Impure (salty) water is heated by the sun, and the water evaporates while the impurities do not. The vapor then condenses onto a surface which captures the water. it's a miniature version of the same cycle which produces rain. Solar stills are commercially available from [SolAqua] and [ADS]. They can also be built fairly easily with widely available plans [EPSEASStill]. Because the water has been distilled, it is purer than water filtered by reverse osmosis.

This method requires solar area, but since it's very lightweight it can be projected out from the platform, or floated on separate units. As solar stills are closed, contamination by



salt spray is not a worry. Lack of rain is usually associated with calm seas and clear skies, thus evaporation is an excellent complement to capturing rain.

Costs range from \$60/m² [ITDGStill] to \$120 / m² [EPSEASTill] unassembled, to \$275 / m² for Agua del Sol's pre-assembled ADS-8. This is pretty expensive, but there is almost no maintenance cost and a still should last for 20 years. We also may be able to design larger stills and buy components in bulk to reduce the price. Ferrocement is a good material for stills, thus we could incorporate them directly into the top deck. These stills produce 2.65 - 7.6 L / m² / day, depending on the amount of sunlight according to EPSEA [EPSEASTill] which is located near the US/Mexican border , or an average of 2.27 L m²/day in a typical country according to ITDG [ITDGStill].

Solar Still footprint and cost per capita:

L/day 25 100 600

m² 3.3-11 13-45 80-265

Unassembled cost \$200-\$1,300 \$800-\$5,400 \$4,800-\$32,000

Assembled cost \$900-\$3,000 \$3,500-\$12,000 \$22,000-\$73,000

These figures indicate the cost of meeting all water needs with solar stills. Any rainfall collected will reduce them. Also, we suspect we can achieve lower costs than our references (\$7.5 - \$35 / L / day). Stills will be most useful in areas with high sun and low rain. The current range of costs is wide, and represents very different levels of cost-effectiveness, thus further research and experimentation with actually building stills is needed. Note that stills are fairly thin, so they can be stored in stacks, and deployed on the top deck during droughts or dry season. Because of their design, stills can also double as rainwater collection area.

Recent research suggests that a clever design improvement can greatly increase the efficiency of a solar still [Goswami2003]. The idea is to use gravity to create a partial



vacuum through hydrostatic pressure, which increases the rate of evaporation. Tests on a small prototype resulted in almost twice the efficiency of flat basin stills. While the method is more complicated, it is not tremendously so, and is definitely worth investigating further for cost-effectiveness [Hoover2003].

Several companies also make floating solar stills, which are inflatable, plastic, and cone-shaped [LandfallStill], [AquaCone]. This could allow a seastead to use extra solar area, which would be a major advantage. While individual units are quite expensive (\$300-\$1000 / m²), we should be able to reduce cost by buying in bulk, constructing larger units, and/or producing them ourselves. Space on the ocean's surface is cheap, but space on our top deck is expensive. Solar stills don't really need to be held safely above the waves by our concrete pillar (except during storms), so deploying them is great if we can manage it.

Multi-Stage Solar Flash Distillation

In flash distillation, the brackish water is not only heated, but exposed to a vacuum to reduce its boiling point. This causes flash evaporation, leaving a residue of salt. Multiple stages can achieve reasonable freshness. This method is much more efficient than simple solar distillation - the energy required to create the vacuum has more of an effect than if it were used to simply heat the source-water further. As a result, it is used in more than 2,000 desalinization plants worldwide.

Like solar distillation, this method requires a large amount of space to heat the brackish input water, which is a definite disadvantage for a seastead. However if some form of distillation is going to be used, it's probably best to use a vacuum (perhaps just through hydrostatic pressure).

Reverse Osmosis

Reverse osmosis uses a semi-permeable membrane as a filter, which can pass water molecules but not contaminants such as salt molecules. It requires continuous pressure, usually from a pump, to operate. One reason R/O is considered undesirable in some environments is that

it uses 4-5 times as much water as it produces (the remainder is waste), but since seawater is, shall we say, rather plentiful where we'll be, this is not an issue. One nice feature of R/O is that it uses little space, and the cost is basically constant for a medium-sized system or bigger, so it is cost-effective on our scale.

Seawater R/O systems are more expensive than freshwater, for example the APEC 600 gallon / day (2300 L) system costs \$7500 (\$3.30/L/day of installed capacity). There are some maintenance costs for filters. The Army Corps of Engineers estimates that in Florida, R/O on seawater has a capital cost of \$1.34 - \$2.38 / L / day and operation/maintenance costs of \$0.01 - \$0.015 / L [UNEP1997, Sec. 2.1 Table 5]. Anecdotal reports suggest that R/O machines are not completely reliable, and will require occasional work [Norgrove1983, pp. 117-118]. .

The main cost of R/O is the electricity used to power the system. According to the specs for the APEC and for Filtration Systems Dolphin series (800 - 1600 GPD), R/O produces approximately 50-100 L / KWhr of energy.

Reverse Osmosis per capita figures:

Water (L/day) 25 100 600

R/O System \$81 \$325 \$1,950

Power Need (kWhs/day) 0.33 1.33 8

Power System cost \$1,000 \$4,000 \$24,000

Maintenance/year \$119 \$475 \$2,850

(Power system costs were estimated using PV panels. Wind turbines will probably be cheaper, but we don't have good numbers). Clearly electricity costs are the dominating factor. R/O costs including electricity are actually pretty similar to a pre-constructed solar still, but much higher than building stills ourselves. However R/O has a significant advantage: installed electricity generating capacity can be used for other things when not needed for R/O. Thus R/O is more flexible than distillation. If the seastead's energy needs or production are erratic, excess capacity can be used to power an R/O system to fill the cistern.

If greywater is available, feeding that to R/O increases efficiency, as reader Doug Jones points out. This is because the unit can operate at lower pressure due to the lower salinity (ie water is closer to pure already). This uses less electricity.

Since we plan for a generating capacity of about 1.4 - 4.1 KWhrs / p / day Power, production of water by R/O is clearly feasible, energy-wise. Because installed R/O desalination capacity is cheap, a good approach might be to install a fair amount of it, then run the R/O plant when there is surplus energy or low water supplies.

Water reuse

We can reduce our need to generate fresh water by using what we have multiple times. While drinking requires a fairly pure source, many other applications can use lower grades of water. For example, "grey water" (water used in the home for non-sewage purposes, including dishes, showers, and laundry) can be used for gardening or toilet flushing. With some processing, grey water can be re-used for other non-potable applications. There is a lot of literature from the environmental movement on this subject.

Importing Water

As with other resources, the feasibility of water importation depends on how far the seastead is from civilization. A coastal seastead could outfit or construct a water-tank barge. The

cheapness and ease of rainwater collection, however, makes this an unlikely option. Still, certain configurations of circumstances (little local rainfall, high water use, close to shore) could make it worthwhile.

29.3 Other Considerations

Norgrove's major concern was cistern size for riding out droughts - 3 month droughts in the tropics are to be expected, and he says you should have at least 20 m³/person of cistern capacity to deal with this [Norgrove1983, p. 104-109]. In our case, 3 months supply would be 2,250/9,000/54,000 L/person. However, rainfall is less variable in the ocean [Era40], and we can always shift more of our electricity towards R/O, so this much storage is rather excessive for our purposes.

One intriguing possibility is to float a bag of freshwater in the ocean as a cheap, large cistern. This would save space and weight on the main structure. However, water actually doesn't take up that much volume. Also, since water can be produced steadily, large reserves imply that too many resources have been spent on water production. Still, for regions with monsoon/drought patterns, or seasteads which experience such patterns due to their migration path, it might be a useful technique.

A concern that must be dealt with is salt water contamination. As waves crash in the ocean around the seastead, small droplets of ocean water are formed that are blown around by the wind. These small droplets can land on exposed soil and slowly increase the soil salinity. Once the soil becomes too salty, crops will no longer grow. One solution is to do all crop growing in covered greenhouses on the seastead, which has other advantages (reduces evaporation, provides a surface for capturing rainwater). If we use a hydroponic system, there is no soil, and it is normal to change the nutrient water and flush the substrate periodically.

Some chemical treatment (such as chlorine) may be desirable in order to prevent contamination during storage and distribution of potable water. Fortunately, because we are starting with clean water, much lower doses are necessary than with chemical purification. In fact, one nice thing about most of these methods is that they result in clean, drinkable water without the use of heavy-duty chemical treatment.

29.4 Water Conclusion

As you can see, there are several ways we can produce water, and combining them will result in the most robust system. Capturing/producing enough water for drinking and hygiene will be quite easy, except in particularly dry locations. Depending on crop requirements, we may have to go to some extra effort to generate or reclaim water for farming using one of the many methods listed. Large-scale traditional gardening will not be feasible.

Chapter 30

Food

[
](images/veggie_plate_big.jpg)

When it comes to food it is necessary to decide how self-sufficient the seasteed should be. There is a spectrum of choices available from importing everything to producing everything locally. Realistically, seasteeds are unlikely to be 100% self-sufficient due to lack of available space, capital, and the fact that people can only stand to eat so much spirulina algae. A reasonable goal for an early seasteed is to grow its own fruits and vegetables and get some of its protein from aquaculture.

30.1 Importing Food

In ancient times, with transport crude, slow, and pricey, most trade involved goods with a high ratio of value to mass...But over the centuries, as transportation grew more cheap and routine, trade in bulky essentials grew practical. Even in the Roman Empire, hauling wheat long distances over water had made economic sense.[Wright2000]





Shipping food is clearly feasible, given how commonplace it is in the modern world. Staples like rice, wheat, and olive oil require a lot of growing area. Yet they are dense, inexpensive to purchase, and easily stored, which makes them ideal to import. So trade is always an option - and will be a necessity if a varied diet is desired on early seasteads. A small community simply cannot produce a large variety of items, so it will be a long time (if ever) before local seastead produce can rival the set of choices available in modern supermarkets. While residents will naturally cut back on imported foods, they'll still want something different on occasion. (This has been true throughout human history). This will be less of an issue on tourism-based seasteads with a mainly transient population.

Another way to look at importing food is to consider the economic idea of comparative advantage, explained by David Ricardo in 1817. He demonstrated that nations prosper most by doing what they are relatively best at. Solar area on a seastead is expensive (we have to build our own land), and agriculture is an industry with a very low income per unit area. So, much like terrestrial cities, seasteads should focus on industries which are not space-intensive. While breakwaters may eventually render new land cheap enough for agriculture, early spar platform seasteads are not going to find it cost-effective. There is nothing unique about importing food, so we won't go into detail.

30.2 Growing Plants

There is a long history of people supplementing their diet with home grown vegetables. During World War II, these gardens were called 'Victory Gardens' and the name has stuck ever since. An excellent guide to home gardening is *Square Foot Gardening* by Mel Bartholomew [Bartholomew1981] (also made into a popular PBS series). This book is notable in that it tries to minimize the amount of time spent in the garden. Most other books seem to focus on gardening as a hobby and tend to soak up as much time as they can get. The goal of square foot gardening is to spend just a few minutes a day on garden maintenance. Its methods claim to produce enough fruits & vegetables for a person in only 4 m².

One real advantage that the seastead has when it comes to growing crops is that it is possible to reduce or eliminate weeds and insect pests. This is extremely difficult to do on land, since the weeds and pests are just blown across the property boundary. With a



seasteed, which is naturally isolated from terrestrial ecologies, care can be taken to minimize the number of insects and weeds that take hold on the seasteed.

While some items (fruit or nut trees) may be grown in dirt outside, we expect the majority of farming be done hydroponically in greenhouses. We present some data on how much area per person is required, but unfortunately our numbers are a bit rough. Also, they will depend strongly on the level of self-sufficiency and type of diet desired.

{ Talk about which plants? It matters a little, but enough? }

Greenhouses

We expect seasteeds to use greenhouses heavily, since they offer:

- Insulation that keeps the frost out and the warmth in. This allows year-round gardening, and thus more harvests per year.
- Protection from harmful UV radiation (if the correct materials are used).
- An enclosed airspace, which allows the operator to control humidity by venting humid air. This helps prevent fungal infections.
- A barrier against pests.
- Less water use (even with occasional air venting).
- Protection from salty spray.
- Outer skin which can easily be used to collect rainwater.

Hydroponics

Hydroponics is a farming method in which plants are rooted in a liquid nutrient solution, rather than soil. This high-capital, high-yield industry has grown 4-5 fold in the past decade. Hydroponics has a number of advantages over conventional field farming:

- Gasses dissolve more easily in water than soil, so the plants are better aerated.
- Nutrients dissolve better in water also, so the roots can be in a more nutrient rich environment.
- As a result, the plant has smaller, more efficient root systems and can devote more of its energy towards growing the parts we want.
- With smaller roots and a more resource-dense environment, plants can be spaced much more closely, which greatly increases yield per unit area.
- Unused water is reclaimed, rather than draining off into the soil as in conventional gardening. The result is much higher water efficiency.
- Labor associated with soil management (ploughing, turning, etc.) is eliminated.
- Clever methods can further increase yield. For example, using multiple beds, stacked vertically, which continually rotate on a frame so that all the plants get sunlight. One manufacturer claims a 3-17 fold increases over traditional hydroponics yields [AB_Hydro].

The main concern of a seasteed is yield per unit area, and many of the advantages of greenhouses and hydroponics are multiplicative on this quantity. For example, twice as many crops per year and twice as dense crop spacing would together mean a four-fold increase in yield. In practice, a factor of 5-10 times is common [Roselle1996], [Willis1992, Ch. 2]. Yields as much as 100 times higher have been achieved [Willis1992, Ch. 2].

It is reasonable to wonder whether these numbers are too good to be true. Keep in mind that we are just talking about crops per unit of area. Hydroponics does use other resources, like nutrients and water, more efficiently than conventional gardening, but this factor is much less than the yield/area factor we're focusing on. For example, more crops per year means a better yield, but also more picking time, fertilizer used, etc. Another downside is that the capital costs of hydroponics can be quite high. Since farmland is relatively cheap, hydroponics are usually not worthwhile, even with the advantages listed above. On a seasteed, however, solar area will be at a premium, and so a technique which minimizes area use is just what we need.

The figures we found for hydroponics equipment cost varied hugely, from \$5/m² for simplified home systems in the third world [Bradley2000] to \$150/m² for commercial first-world operations [AmericanHydroponics, sample costs]. There's a good chance seasteeds will be towards the expensive end of this range in order to maximize yield, but experimentation and DIY could bring costs back down. Empirical data gives yields for many hydroponically grown vegetables are of 50-250 g/m²/day.

It is important to be careful of water-borne diseases, since many plants share the same nutrient solution. For this reason, in most indoor operations, the growing medium is sterilized between crops [Willis1992, Ch. 2].

Genemod Saltwater Plants

Gardening, even with hydroponics, will use considerable fresh water. Recently, scientists have produced genetically modified tomatoes which can be grown in saltwater. The plants extract salt from the water and store it in their leaves (which offers intriguing possibilities



for reclaiming salinated land). The most exciting part is that the plants are made saltwater tolerant by the introduction of a single gene which codes for a protein for dealing with salt. This means mean that many plants could theoretically be modified in the same way. However, the plants are not able to deal with pure seawater. Also, we won't be able to compost the salty leaves. So we save freshwater, but lose some organic material [Zandonella2001].

Note that GMO plants are unlikely to take over the ocean, since they can't deal with pure saltwater and they need to be immersed in a nutrient-rich medium. In general, they are not adapted for the ocean, which makes them far less likely to spread than GMO's on land.

Seaweed

No seastead diet would be complete without the one "plant" evolved for the ocean environment. Seaweeds are actually a form of algae, and people have been eating them for thousands of years, particularly in the Orient. None are known to be poisonous, although some can cause discomfort. Extracts such as agar and carrageenan are derived from sea plants and used in a large variety of packaged foods. Seaweeds are rich in vitamins, minerals, and protein, and can be used to fertilize other plants. Ironically, the vitamin C in seaweed might have saved early seafarers from scurvy, if only they'd known to scoop it up! [Neumeyer1982, Chapter 6].

Seaweed can be cultivated by placing fragments on ropes or other substrata and growing them in the ocean.

Spirulina Algae

Spirulina has the most remarkable concentration of functional nutrients ever known in any food, plant, grain, or herb. On top of this, spirulina delivers more nutrition per acre than any other fod on the planet. This has extraordinary implications for more efficient and less damaging food production for the future.

Every day new research brings to light the wonders (hidden) in microscopic algae.
[Spirulina1994, p. 5-6]

While books like *Earth Food Spirulina* can sound a bit over-the-top at times, author Robert Henrikson knows the subject well - he's the president of Earthrise Farms, the largest spirulina farm in the world . Blue-green Spirulina algae, used as food by the Aztecs , is 65% protein by weight, and is a complete protein source. Because it is such a simple life-form, it is much easier to grow and harvest than crops or livestock. Algae waste no growth on inedible parts, and every cell is a seed. Their life-cycle is simple, and they grow at an exponential rate until nutrients are exhausted (doubling biomass every 2-5 days). Spirulina can grow in sea water, and be eaten without any processing. It contains vitamins as well, including A, E, and B12 [Spirulina1994].

It has been suggested that spirulina provides more nutrition per acre than any other food - and without requiring fertile soil or fresh water. Current production costs in large facilities range from \$10-\$20 / kilo. Compared to the extravagant conventional methods of obtaining protein from mammals, spirulina provides an incredibly efficient one-step food chain, as can be seen in the table below.

Resource Usage To Produce One Kilogram of Protein: (Parenthetical italics indicate values relative to Spirulina)

Land (m ²)	Water (Liters)	Energy (Gigajoules)
Spirulina 0.5-1.0 (non-fertile)	2,500 (brackish)	5.5
Soybeans 16 (<i>16-32</i>)	8,860 (<i>3.5</i>)	11.7 (<i>2.1</i>)
Corn 22 (<i>22-44</i>)	12,300 (<i>4.9</i>)	5.5 (<i>1</i>)
Grain-fed Beef 193 (<i>193-386</i>)	104,000 (<i>42</i>)	456 (<i>83</i>)

Another advantage of spirulina is that it produces oxygen as a positive externality. Unlike some algae, it is not nitrogen-fixing, and so requires a supply of nitrogen (perhaps from an artificial upwelling, such as a wave pump). One intriguing use for spirulina is to concentrate nutrients from seawater so that they can be used to feed more complex life forms. While spirulina thrives in salty and alkaline water, most strains don't grow well in seawater, which has low carbonate and high magnesium and calcium. But special seawater strains are being developed.

Mycoprotein

Fungi are another lower life-form which can be used as a food supply. Protein derived from them is called mycoprotein, and produced by continuous fermentation. It has the advantage of being "chewy", as well as absorbing added flavors and colors. Unfortunately, as reported by the CSPI, there have been many negative health reports about the commercially available mycoprotein [CSPIQuorn]. Medical investigation suggests that individuals with mold allergies may be allergic to mycoprotein as well [Hoff2003]. This problem seems to occur only in a minority of the population, but we advise caution, since serious allergic reactions can be fatal. Still, this is another potential way to grow protein.

Resource Inputs

Resources necessary for food production include water, light, fertilizer, labor, and space. Light is provided by the sun, water by the methods outlined earlier, labor by the residents,

and space by the seastead. Fertilizer is a more complicated issue, as this excerpt from an article on space station biosystems demonstrates:

Previous work on hydroponic systems have shown that nitrogen balance cannot be achieved, especially with systems that involve organic matter (Jewell et al. 1993). Some nitrogen "leaks" from hydroponic systems, most likely as a result of micro anoxic environments where conditions for microbial denitrification are favorable. These conditions include zero dissolved oxygen and the presence of biodegradable organic matter. When these conditions occur many bacteria have the capability to use electrons from oxidized forms of nitrogen [NO_3^- (nitrates) and NO_2^- (nitrites)] and reduce these valuable plant fertilizers into unavailable nitrogen gas. In sewage treatment hydroponics, between 25 and 50% of nitrogen has been observed to be unaccountably, presumably because of denitrification.

Hydroponic systems that maintain water free of biodegradable organics, high oxygen levels, and low oxidized nitrogen concentrations will discourage loss of nitrogen via denitrification. A conservative design would assume that as much as a quarter of the cycling nitrogen will be converted to nitrogen gas (N_2), or a total mass of 15 g of nitrogen must be transformed from N_2 to organic nitrogen each day in a closed biosystem.

A sustainable system must replace this nitrogen fertilizer loss via nitrogen fixation. Two biological options are available to convert N_2 to organic nitrogen which can be subsequently biologically regenerated as ammonia-nitrogen or nitrate-nitrogen: symbiotic N_2 fixation in legumes and N_2 fixation in blue-green algae. An option that could be used to generate useful biomass with minimal side effects would include symbiotic N_2 fixation using legumes, possibly food producing legumes such as soybeans.

Unfortunately, nitrogen fixation is a highly energy intensive process, and rates are relatively slow. Depending on the length of growing season, documented fixation rates vary from 0.008 to 0.18 g N/m² -d. Growing areas to make up a 25% loss would be 83 m² to 1,900 m². This nitrogen management plant area could be equal in size to hydroponic food production. It will be assumed that no human food results from the nitrogen fixing hydroponics.

A summary overview of the closed biosystem for one adult is shown in Figure 5. Total plant growth area is 290 m². [Jessell2001, pp 9-10]

Fortunately, we don't need to manage our nitrogen balance quite as carefully as a space station. For instance, we can purchase nitrates produced on land using the Haber-Bosch process. Those seasteams which seek completely sustainable farming, however, must keep this problem in mind. Composting and similar closed-cycle techniques can reduce the amount of new fertilizer needed. Composting is covered in both *Building for Self-Sufficiency* and *Square Foot Gardening*. There may eventually be clever methods of extracting fertilizer from the ocean (artificial upwelling, concentrating nutrients with algae, etc.). But until then, even with these techniques, some fertilizer will need to be imported.

Artificially lighting a greenhouse to produce a longer growing day takes about 50 - 175 W / m² of power [MBR, Ch. 5], [Andrew1994]. At 20m²/person, this would be 1 - 3.5 kW / hr. So 12 hrs/day, 365 days/year of lighting would use 4-15 mWhrs/person/year, which is significantly more energy than is required for personal use. Since power onboard a seastead is expected to be expensive, this will probably not be worthwhile. For example, using photovoltaic panels for this purpose would be absurd, since they'd take up around

10x as much space as the plants they were providing electricity to light! Still, it is possible that special factors (excess power, cheaper power generation, trade embargo) could change this.

There are some other ways we might increase grow area. Mirrors or other sunlight collection devices could be used to gather sun from a larger area than the platform, lighting a second deck. Another possible solution would be to make small rafts or barges as auxiliary grow areas. They would be constructed cheaply, only able to withstand typical non-storm seas, and deployed around the stead. They would be sized so that in foul weather they could be hoisted up under the stead for protection. Fresh water could be piped to the units, or they could contain integrated [solar stills][].

30.3 Raising Animals

There are several ways we may be able to supplement the production of our gardens, such as fishing, aquaculture, and raising farm animals.

Fishing

Fishing is heavily regulated inside EEZs, so it may be problematic. Also, a seastead can't just zoom around looking for fish like boats do. However, seasteads may find fishing economical if they are in locations where the stock has not been depleted by commercial farmers. This could even make for a profitable seastead business.

Aquaculture

Aquaculture, the process of raising ocean foodstuffs, is the maritime equivalent of ranching. This practice has a long history: Chinese manuscripts indicate that fish culture has been practiced there since at least the 5th century BC, and the Romans raised oysters. The list of animals that have been raised commercially starts with Abalone, Amberjack, Anchovy, and continues on for another 100 species [WorldAquaculture].

Unlike the commercial fishing industry, which is slowly succumbing to the exhaustion of its commons, aquaculture systems offer long-term promise. This is true whether you look at it from the environmentalist's perspective of increased sustainability, or the economist's viewpoint of more clearly defined property rights. Given the incredible impact of the agricultural revolution, we can't help but speculate that the movement from hunting wild fish to farming domesticated ones will also produce major gains in efficiency and worldwide food production.

Saltwater plants dovetail nicely with aquaculture because the waste products of fish can be used to fertilize plants. This system is called Aquaponics. For example, on Carl Hodges' experimental farm, shrimp grow in saltwater, then tilapia, and then the water is used to nourish a saltwater plant called Salicornia (used for vegetable oil) [Hinman1996].

Aquaculture is roughly divided into intensive and extensive. Intensive is more complex, as it involves creating an artificial environment in which to raise the product. Extensive can be as simple as "fencing" off a section of ocean with nets, and raising some fish inside it. By choosing species which feed on the natural detritus of the ocean such as algae, no food supply is needed. While this tends to be a low-density, slow-growth method, it's also low-

effort and uses renewable resources. N55's SMALL FISHFARM is an example of a simple design [N55BOOK, pp. 167-176].

Farm Animals

Raising a small number of dairy animals will probably be worthwhile, such as chickens (for eggs) and cows (for milk). Chickens run about 8 to the square meter [SpaceSettlements, Ch. 5], although growing their feed will use area as well. Chickens, cattle, rabbits, and similar animals can be grown for meat, producing edible portions of about 1/5th to 1/10th of the mass they consume [SpaceSettlements, App. C]. Unless a cheap food source like algae can be fed to animals, importation is probably a better way to get meat.

30.4 Area Requirements

{ more numbers would be great here, if anyone has them }

Numbers in the literature on the area required for self-sufficient food production vary widely. This is not surprising, since the environments discussed are very different. Meat takes much more space than vegetables and starches, and a complete diet takes much more space than supplementary fruit, vegetables, and dairy. Conventional, open-field agriculture uses a lot more room than hydroponics on a space station.

We think the latter is more relevant to us than the former. Common sense tells us that when a resource is scarce, people find ways to use less of it. Farmland is much cheaper than seastead deck space, so we will use the latter more efficiently. We'll have to use more of other resources to do this of course - if there was a way to use less space with no cost, it would already be part of standard practice. But while we aren't getting something for nothing, we can be pretty sure that our yield per unit area will be higher than on land. One advantage we have compared to space stations is that we can draw from the resources of the ocean, including fish, seaweed, and nutrients, as well as importing from the outside world.

A representative land-based figure is the Biosphere II project, which attempted to be a completely closed ecosystem. They grew 80% of their food on 253 m²/person, which would mean 316 m²/person for self-sufficiency.

Food requirements are about 3.1kg [Shipman1989], and 2000-3000 cal per person per day. A NASA project on space station design says that about 15-50 m² of solar area are necessary to provide a standard North American diet with high-yield techniques [SpaceSettlements, Ch. 3 and App. C]. This includes cattle and chicken raised for meat, which are area-intensive. On the other hand some of their numbers strike us as a bit optimistic. A different space station study suggests that all area required for complete self-sufficiency, including waste / water recycling, food self-sufficiency, and nitrogen balance, is 290 m²/p [Jewell2001].

Sailing the Farm, a book about self-sufficient boating, implied that using a cabin for food production (5-10 m²) could make a substantial contribution to the sailor's diet. As mentioned earlier, Square Foot Gardening states that only 4 m² / p are necessary for fresh vegetables.

Based on these figures, complete self-sufficiency would require about 50-300 m² / p, which is not practical at current cost estimates. However, a substantial amount of food (vegetables, fruit, dairy) can be grown in only 5-20 m² / p. Fishing, aquaculture and dense imported foods (grain, cheese, meat) will round out the seastead diet. Vegetarian tendencies and a willingness to eat unusual things like algae will shift seasteeds farther towards self-sufficiency.

Chapter 31

Defense

Without the protection of a large government, defense is obviously a necessary concern. Let's consider the possible opponents a seasteed might face in battle. They basically fall into two categories - pirates and navies.

31.1 Against Pirates

As described in the piracy section , most pirate attacks are either very small-scale, preying on unarmed ships, or very large-scale, with organized groups stealing entire cargo ships. A seasteed will be too tough for small pirates and not financially worthwhile for big ones. Conventional, readily-available weapons such as large-caliber rifles and machine guns should be sufficient for defense. Because of its platform structure, a seasteed is an easily defended against hand weapons, and being a huge mass of concrete it will be quite tough. A few gun emplacements on the underside of the platform would make it a hellish place to attack with a boarding party carrying small arms. (Although these emplacements might be a bad idea by making the seasteed seem more warlike to nearby nations - we must always keep these political factors in mind).

31.2 Against Navies

Unfortunately, a seasteed will still be quite vulnerable to larger weapons. Concrete is tough but far from indestructible, and a fight against the other kind of opponent, a serious military force, would be hopeless. The central column could be blown up, and the top deck's solar panels and greenhouses make a juicy air target. A seasteed cannot easily be made strong enough to withstand naval guns, torpedoes, or missile fire, and it cannot afford guns large enough to have a range advantage on enemies. Slow movement makes it a sitting duck. A real warship could sit at a distance and barrage it with impunity. Since these new nations will start small, their potential military budget is many orders of magnitude lower than current nations.

Even if a seasteed cannot win, it is still worth considering the value of defense as a deterrent. The more damage a seasteed can do to its attackers, even while fighting a losing battle, the less likely it is to be attacked. Additionally, because of the private, competitive, and small nature of seasteed government, it is likely that defense money will be spent efficiently. As Bob Murphy points out, we won't be paying \$600 for a toilet seat, so it may well be possible to find cost-effective defensive deterrents [Murphy]. For example,



sea-skimming anti-ship cruise missiles like the Chinese Silkworm are fairly cheap and quite effective. And a rocket engineer in New Zealand has set out to prove that you can build a small cruise missile for \$5,000, thanks to the decreasing cost of many of the important components [Simpson].

31.3 Prevention, Not Cure

As independent and sometimes macho individuals, it can be difficult to admit military inferiority. But since there is little a seastead can do to stop a real navy, they shouldn't spend too much money to try. Seasteads should focus on the ounce of prevention rather than the pound of cure. Other than the ability to damage the attacking force through defensive deterrents, most prevention is political rather than military. Avoid angering terrestrial nations enough to provoke an attack. Be redundant - build many floating cities in many places. Be willing to compromise some freedoms in order to maintain others. Be useful. If you supply advanced medical technology to government officials, it's less likely someone will blow you up. Work with existing nations - have a good relationship with your flag issuers.

The economic and military inferiority of seasteads may only be temporary. As a sea-city gets larger, it is more likely to anger existing nations, and it will be more economically feasible to spend money on defense. Perhaps, over time, seasteads will become large and rich enough to join the ranks of dangerous nations. But it's going to be awhile.

Chapter 32

Transportation

{ I'm not sure of the best title for this, Transportation is pithy but its about staying still as well as moving. Its really more about "location control", but thats kinda awkward. }

Is the seasteed a boat or an island?

If it's an island, then it should be attached to the ocean floor to prevent it from moving around. Since the ocean floor is typically miles from the ocean surface, this is actually quite challenging. Seamounts and shallower areas present less difficulty, but using them greatly reduces the number of potential locations.

Our preference is to treat the seasteed as a boat. For one thing, this means that all of the international law that applies to boats can be applied to a seasteed. In addition, the seasteed may be able to avoid bad weather (by season at least, even if it's not nimble enough to dodge individual storms). Also when supplies are low, the seasteed can find a port and resupply itself.

Once the first few mobile seasteeds have been deployed, they can aggregate by simply rendezvousing at a agreed upon location and lashing together into one bigger sea village. Over time the sea communities will evolve to sea cities. Whenever someone becomes annoyed



with the current state of a seastead community, it is possible to just disconnect and take their seastead someplace else.

32.1 Staying Still

Mooring equipment is very expensive, especially the lines. Unfortunately the lines limit what depth water one can anchor in. For example, a set of High Molecular Density Poly Ethylene (HMDPE) lines for anchoring in 2500m of water costs approximately six million dollars - without the attachment hardware or anchors. These and other synthetic lines are the only real acceptable solution for deep water anchorages, as braided steel lines are too heavy and can corrode. In shallower water, however, the lines become proportionally cheaper.

The anchors themselves are fairly simple suction devices, basically a hollow tube with a cap on one end and a pump in /pump out valve. You drop the anchor to the bottom, pump out all the water, and it sucks itself into the sea floor. To retrieve the anchor you pump it full of water and it pops out of the sea floor. The sea floor for the most part is covered with about 50' of sludge and muck which actually makes for a pretty good hold.

Because of the high cost of lines, potential anchoring locations are limited to areas of relatively shallow water, such as seas and coastal areas. In the deep ocean, seasteads will just have to drift, unless they anchor on a convenient seamount. Still, an anchoring system will be quite useful and is likely to be one method for location control.

An other alternative for station-keeping is to have steerable propellers connected to a GPS (Global Positioning System). The system would push the the seastead to its desired location whenever it starts to drift off location. However, this would continually use fuel, so is most likely to be feasible when drifting forces are quite low.

Newton's first law of motion tells us that a seastead will happily sit still unless external forces act on it. The main external force moving a seastead is the action of ocean currents. This suggests an additional strategy for keeping still, which is to go someplace where there is not much current. The equatorial doldrums are one such place. Another is the center of the circular current gyres, where millions of tons of trash has accumulated [NaturalHistory2003]. This "do-nothing" strategy has the wonderful advantage of being cheap. However it had best be accompanied by a plan to deal with the possibility of being pushed around by an unexpected storm or current.

32.2 Moving

Powered Movement

The submerged flotation gives seasteads a lot of drag. However, friction from drag is proportional to velocity **squared**, so as long as we move slowly it's still manageable. Renewable energy could be used to directly power a propeller. For example, simple vertical-axis wind turbines could be connected directly to propellers, or the up-and-down motion of waves could be converted to rotation. Or we can use our standard methods of electricity generation to power electric trolling motors. These methods will appeal to the environmentally conscious, since they do not require burning fossil fuels, and may even prove to be cost-efficient. However, they are unlikely to generate much speed.

The simplest method is probably for a separate, diesel-fueled tugboat to pull the platform. Used tugs can be had for anywhere from \$50K to millions [Tassins Marine Transportation],



depending on their age and the power of their motors. One advantage of a tug is that it could be used to lug barges of supplies back and forth when the seasteed doesn't need pulling. Diesel engines could also be built into the structure. A powered seasteed could potentially be connected to an unpowered one and used as a tug itself.

Active propulsion will clearly work for small course adjustments, or occasional location changes. It is unclear whether it will be feasible to use continuously. Even though our speed is slow, we are moving a large object, and currents will constantly be pushing us. So relying on active propulsion will add to the operating expenses of a seasteed, as well as reducing its self-sufficiency due to the huge energy drain. Under the tourist business model, however, it may be practical. Cruise ships move around constantly, at fairly high speeds, and are profitable while doing so. A more permanent population, however, has less reason to move and more reason to cut daily expenses.

Unpowered Movement

The easiest method of unpowered movement is drifting. This is not so disastrous as you might think, because ocean currents are roughly circular, as can be seen in the currents section. With some fine-tuning, a seasteed could be pulled by them forever, circling towards a pole and then back to the equator. Moving radially will change the cycle's period, which may be desirable to avoid seasonal storms. Active propulsion can be used to transition between current formations. A Deep-Seasteed could potentially enjoy endless summer by switching hemispheres twice a year when the current brought it close to the equator. Another option is to go someplace like the equatorial doldrums where there is little current, and drifting basically means staying still.

Sails are an interesting propulsion option. They could be deployed in the space below the platform and above the waves, with the spar itself acting as a mast. A keel would of course be necessary, perhaps by making the submerged flotation oblong in shape. Because water is much denser than air, it takes a high ratio of sail area to wetted area to propel a boat. Seasteeds have a lot of wetted area, so they'd need a lot of sail. Large sails are quite expensive, movement would be slow, and a square-rigged seasteed would be unable to head much into the wind. The fact that the wind is a powerful sustainable energy source

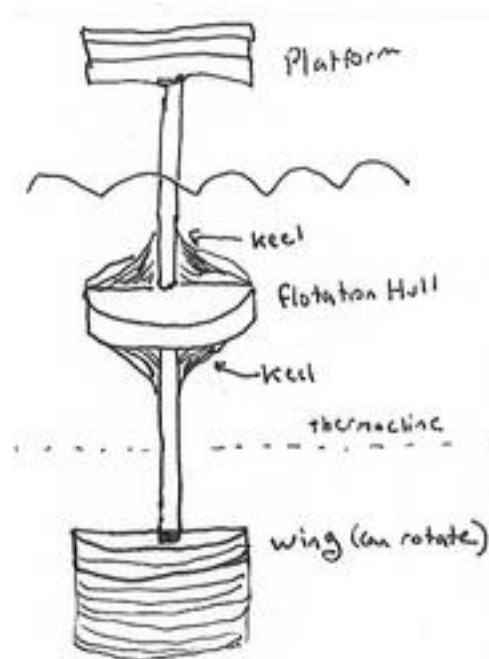
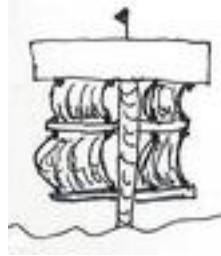

may turn out to compensate for these disadvantages, or it may prove to be an impractical option.

An even more interesting and difficult idea, suggested by Corwyn, is to use a submerged wing to "sail" the ocean currents. Wings work by converting the flow of a fluid into sideways motion via Bernoulli's principle. Sails are one example of this, using air as the fluid. Water is also a fluid, and hydrofoils use this to lift their hulls out of the water with force from submerged wings.

Because fluid must flow past the wing, one uniform current would not be enough. The seastead would drift with it, and the water would appear still. In order to sail, we need a varying current, so that we can use the differences to generate motion in other directions. Fortunately, it is not uncommon for the currents at the very surface of the ocean to be different than deeper currents. The thermocline, a region of rapid temperature change, is usually 10-200m down, and it separates the surface "mixed layer" from deeper waters. Currents are often different above and below the thermocline.

There are substantial problems with this method, of course. Current differences are likely

to be small and variable, thus imparting little speed and requiring re-adjustment of the angle of the wing. Transmitting the forces along masts long enough to reach into regions of varying current is difficult as well. It may not be feasible. However, there is a certain elegance to this method of propulsion, and it would be truly magnificent for a seastead to sail, not drift, in the ocean's currents.

Reader Edward T. Felton suggests a variation on this, with an underwater kite instead of an underwater sail. That is, suspend a structure with large cross-section from the seastead, reaching down to the desired current region. It will then pull the structure in the direction of that current. While this allows for less flexibility in direction of movement, it also poses less engineering challenges.

32.3 There and back again

Besides moving around the entire seastead, we'll need various methods of bringing people and goods there and back again. Obviously the size of this cargo stream depends on how much the seastead is importing (its self-sufficiency), how much it is exporting to the world, and the size of its tourist industry. If the seastead is functioning as a resort, it is crucial to have good ways of getting passengers there and back again. The closer to land, of course, the cheaper this transportation will be. There are two basic methods of moving over water:

Floating

The slowest and cheapest method is floating, whether on a sailboat, rowboat, motorboat, or experimental rocket-powered hydrofoil. Boats typically have speeds of around 10-30 knots. Thus a seastead just outside the 12 or 24 n.m. territorial water limit could be reached in 0.5 - 2 hours. Getting to a seastead outside the 200 n.m. EEZ would take around 10 hours. More distant seasteads would require days of travel.

For the renewable energy advocates, there is an appropriate boat propulsion technology which is extremely mature, namely sails. The backup diesel motor can be replaced with an electrical motor. Several manufacturers already make electric boats, though they tend to be small, and it is not difficult to convert existing boats [ElectricBoats]. Still, the juice has to come from somewhere, and it does take a fair amount of energy to travel long distances.

Boats have a number of advantages. They are relatively inexpensive to operate, and reasonably quick for short distances. They can take many people or a large amount of cargo. However, riding in them becomes rather unpleasant when the weather is bad, and sometimes even dangerous. For long distances, they are a bit slow. Boats are the clear choice for cargo, and for transporting passengers over short distances. In good weather, for passengers who don't mind a slow trip, they are suitable for longer distances as well.

As we mention when discussing the dock, transferring cargo between a ship and seastead may be a dicey proposition. Solving this problem will be a big factor in whether we can ship goods to a seastead, which is a big factor in how much it costs to import and export goods.

Flying

More distant seasteads may wish to fly people in and out using planes or helicopters. A several hundred mile trip would only take an hour or two of flight time, and even a seastead in the middle of the ocean should be reachable in half a day or less. While this method is much quicker, it's also more expensive and requires more infrastructure. Seaplanes can

land on the ocean, but only in very calm or protected waters. Regular planes require a long runway. Helicopters only need a small landing deck, however they are more expensive and dangerous than airplanes.

There are special STOL (Short Takeoff and Landing) airplanes which need less runway length (as short as a couple hundred feet). Our initial Seastead Lite design is large enough for one of these. However, STOL planes tend to have relatively low cruising speeds (120mph) and low passenger capacity (a few people). This makes it difficult to use these planes to transport resort visitors, unless the distance is short enough to allow many trips per day. Helicopters may be superior to STOL aircraft for this reason - the same amount of area as an STOL runway could be used to land many helicopters.

Groups of multiple seasteeds make longer runways possible, at which point planes are an excellent option. Groups large enough to have a breakwater can have seaplanes land in their harbor, or have long runways. Before then, either helicopters or STOL aircraft can serve to transport passengers willing to pay extra for a quick ride, as well as for medical emergencies. Seasteeds with protected waters can be serviced by seaplanes. Individual seasteeds, far from land, without protected waters, will have to use expensive helicopters if they want to move many people.

32.4 Transportation Summary

Early, smaller steads will probably be towed into place and anchored, as that is the cheapest and simplest technology. Deepseasteeds will likely use a combination of these methods, spending some time at anchor, some time drifting, and occasionally using active propulsion. They may also try being set adrift in the doldrums.

Chapter 33

Shelter

{Wayne & Andy}

There is not much that we would like to say about shelter. The shelter can be as simple as a tent or as complicated as a multilevel house. For small initial prototypes, an option is to simply get some sort of inexpensive RV (recreational vehical) trailer and simply park it on one end of the seastead. An RV trailer provides sleeping accomedations, a small kitchen, a small bathroom, a place hang out, etc Since most RV trailers already have separate grey and black water tanks, it sould be very easy to integrate the trailer into the fresh water management system.

Edward Felton expands this suggestion:

something I've seen done up north (minnesota) for "travel trailer" type shelter, to be able to survive winter (and would help survive storms) would be to simply build a concrete structure surrounding the trailer (box it in) with an offset entry ... that way you get cheap living space, inside "cheap as it can be build" hardening.. definatly not pretty, but should give "stormproofing"

Homes in the US average 55 m2 per resident, while in Europe the average is 30 m2 [Chandler, p. 121]. In Beijing, China, it is only 3.3 m2 per capita [Silvertown, p. 55]. The US has an additional 21 m2 per capita of support space (offices, schools, restaraunts, warehouses, etc.) [StatsUS1988, tables 1237-1239]. As with other resources, space is more expensive on a seastead and will be conserved, allowing less usage than on land. A NASA study on space settlements suggested 67 m2 of footprint and 1738 m2 of volume [SpaceSettlements, Ch. 3]. While their budget is higher, their self-sufficiency requirements are higher also, and ocean provides us extra space for some uses.

The seastead's shelter will, of course, need to be strong enough to handle the worst storms which may occur in the areas it is expected to travel.

Chapter 34

Communications

The presence of internet on a seasteed will make a substantial difference in what sort of people it appeals to and how long they are willing to stay there. A connected seasteed will be much more attractive as a permanent residence to the techie crowd. While there are people who don't mind being out of contact (and some who see it as a plus), there is a much larger and rapidly growing population who don't consider themselves isolated if they can get online.

This makes the economic situation easier because the seasteed can export technical expertise. Working professionals will be able to visit more frequently and stay longer if they can still keep in touch with the office. This also helps the seasteed make the transition from vacation home to permanent residence for its inhabitants. Note that with enough bandwidth, voice-over-IP can be used to make telephone calls, thus solving another communications problem (although it may be a little annoying with satellite lag).

Seasteeds which are close to land can use point-to-point links of various kinds, such as microwaves. While there are some minor issues, it will be much cheaper to get significant bandwidth, and have much less lag, than satellites. This is another advantage of being close



to civilization. Laying cable is incredibly expensive and unlikely to be feasible for quite awhile. However, there is already cable laid to connect many island nations. It might be possible for a seastead to anchor over a junction and connect there.

The most general and widely applicable way to have internet in the middle of nowhere is with satellites. The technology is currently evolving rapidly, so by the time seasteads are built it is likely to be more advanced than it is now. Some points:

- If the seastead is moving, its satellite dish needs to be mounted on a tracking system to compensate. Fortunately it will be moving pretty slowly and such systems already exist.
- KVH TracNet is a commercial system which costs \$6000 and allows mobile marine access to the DirecPC system. It tracks and is gyrostabilized, and supports speeds of 400Kbps down / 56 Kbps up. TracNet covers the caribbean, mediterranean, and near-shore areas around North America, South America, and Europe (coverage map).
- There are quite a few satellite internet providers. The old-style ones, who started out selling phone service, are prohibitively expensive for anything other than email, ie inmarsat, Iridium, and Globalstar are \$1-\$2 / min for a 5-10Kbps connection or a phone call (!).
 - The new internet-oriented services are much more reasonably priced, but they are mostly intended for land-based use, mainly in the continental US.
 - Starband (which covers the eastern half of the pacific, as well as the caribbean) is ~\$70/mo for 150-500Kbps (I think the uplink is much slower). Their customer service claims they "cannot be configured to work outside the 50 US states", but this is probably false.
 - DirecPC is \$50-\$100/mo for 400/56.
 - DirecWay is \$100/mo for 400/128, or \$500/mo for ~20 users each getting 128/400.
 - Tachyon service is \$600 - \$2000/mo for 800/128 (2GB/mo) (up/down) to 1544/256 (10GB/month). While they are only renting two satellite transponders right now, they plan to slowly and steadily increase their coverage.
- Techniques such as web proxies with a document cache on the seastead can reduce bandwidth usage.
- When the cost is split among the many residents of the seastead, a high-quality service such as Tachyon could still be affordable.
- While most of these providers don't explicitly support marine applications, it will be worthwhile for a seastead to put significant effort into customizing them if necessary, for example by mounting the dish on a base which automatically tracks the target satellite.
- This is a rapidly improving technology, so by the time seasteads are built it is likely to be cheaper, higher bandwidth, and more widely available. For example, 36Mhz transponder equivalent use for internet traffic increased by an order of magnitude from 1/98 to 4/01(!).
- Coaststeads and steads in the caribbean will have the easiest time of it, since they will be in range of the land-oriented satellite services, (ie DirecWay coverage map).

- A downside of satellites is high lag, or length of time it takes for a signal to travel. Realtime applications like gaming, or even using a shell on an off-site computer, suffer from this. It's important to recognize that satellite is not a magic bullet. Lag is high because satellites are in geosynchronous orbit. That means they are high enough that they orbit at the same speed as the earth, which keeps them over the same point on the earth's surface. This is convenient because one satellite can serve one region, but it takes a quarter second for a signal to get up and back. One possible solution is to use a network of satellites in Low Earth Orbit. These have less lag, but because they move, it takes many satellites to provide continuous coverage, which is incredibly expensive. So far the ventures which have tried this have all gone bankrupt (Iridium, Teledesic), but it is likely to happen eventually as space technology improves.

Chapter 35

Appliances

Because of the limited resources available to a seastead, special consideration is needed when choosing appliances. While the below is neither an exhaustive set of appliance types nor of possibilities for each appliance, we believe that it demonstrates the widespread availability of power and water efficient solutions. Similar choices can be made for other "modern necessities". Note that we've chosen to structure this as a discussion of appliances and their replacements (ie "hot water heater" rather than "hot water"), rather than a provision of services.

35.1 Heater

Because the seastead has a huge thermal mass and floats on the water, temperature extremes will be moderated. Some heating may still be required, depending on season and location. We have a variety of possible heat sources. We can burn fuel, such as diesel, hydrogen, alcohol, or propane, or we can directly convert electricity that we have stored or generated into heat. While getting heat from the sun is a technology as old as the earth, being able to turn wind into heat is a nice improvement.

We can also use the traditional techniques for energy efficient heating to reduce energy costs. Have a lot of insulation, use efficient windows, face them south, store heat during the day, and trap it at night. The environments that a seastead expects to be in, the cost of energy, and the cost of such techniques will dictate whether they are used.

An additional source of seastead heat is waste heat from diesel generators, inverters, batteries, anything else that generates heat as power-loss. Heat exchangers can be used to scavenge this, which increases the effective efficiency of the appliance.

35.2 Air Conditioner

Cooling is unlikely to be a big problem on a seastead for the same reasons as heating: temperatures will be moderated by the thermal mass of the ocean and the seastead. There are a lot of ways to cool seasteams without using power-hungry air conditioners.

Cooling is easier than heating because we can tap a large source of available coolness. We're not talking about our nation's teenagers, but about ocean water several hundred feet below the surface. An intake can be placed on the submerged buoyancy portion of the structure, and the only power cost is for pumping. The energy can be partly recovered by running it through a small turbine on the way back down. it's probably worthwhile

having this turbine because there are a number of other circumstances under which we'll be draining water from the platform, and we might as well get some energy out of it.

Evaporative cooling with a device called a swamp coolers is another interesting low-energy method. Air is sucked through wet pads, causing the water to evaporate and the temperature of the air to drop. The result is a breeze cooler than ambient air temperature which only requires electricity for the fan and a supply of water. The process is depicted in the flash animation below:

Animated GIF for those w/o Flash Image courtesy of Opalcat, from her Swamp Cooler page.

If saltwater is used, minerals will quickly build up on the pads (scaling). Frequent rinsing in fresh water may alleviate this, and it may or may not be worth using salt depending on how much fresh water is available. Another potential difficulty is that swamp coolers work poorly when humidity is high, which is usually the case over the ocean. Despite these disadvantages, the efficiency of evaporative cooling makes it a strong contender when conditions are appropriate.

{Swamp Coolers are really neat, but humidity over the ocean is always very high so I think they may be no good for us. This section may be removed - P}

35.3 Refrigerator

There are a number of possibilities for refrigeration. It is important to do a good job, since the refrigerator must keep food cold 24 hours a day. In a standard kitchen, it uses more energy than any other kitchen appliance - around 5 kWhrs/day.

Conventional refrigerators are extremely inefficient. Since electricity is cheap, most people buy a refrigerator based on its color and shelf arrangement rather than its efficiency. Some fridges actually have heaters in the frames to prevent moisture from collecting on the seals and generating mildew. The "frost-free" systems are basically heaters that briefly bring the air in the freezer compartment above freezing to remove the frost. The heat from the compressor and condensor flows past the refrigerator as it escapes. Convenient, yes. Efficient, no.

While some of the commercially available energy-efficient refrigerators are not much better, others like the Sun Frost line use less than 1 kWhr per day. Its hardware is on top, so the heat produced escapes away from the fridge. Good insulation is also very important to reducing the energy requirements.

Strange though it sounds, solar heat can actually be used directly for refrigeration. The secret is an absorption refrigeration cycle discovered in the mid 1800s. A mixture of ammonia and water is heated in one area, and the ammonia evaporates, moves to another area, where it is cooled and condenses. When the liquid ammonia evaporates, it cools the surrounding area. This is an external-combustion system which can use any heat source for power.

The method was used in an icebox cooler called the Crosley Icyball sold in the 1930's [IcyBall]. The same principle was behind a recently-built solar icemaker, described in Home Power magazine. It used a parabolic trough reflector to focus sunlight onto a tube filled with ammonia. During the day, it charges, and at night, it produces cold which can be used to make ice [SolarIce].

Like many renewable energy systems, this method has the advantage that it requires almost no maintenance and will work forever. 70-year old Crosley's found in antique stores are often still functional. It uses the sun directly, and fairly inexpensively, both of which



are useful. Other heat sources (like stored fuel) can be used on cloudy days. One drawback is that ammonia is a nasty gas, but a well-designed system should be safe.

35.4 Hot Water Heater

We can heat our water through a number of means, including passive solar heating, burning fuels, electric heating, and capturing waste heat when it is available. Passive solar heating is likely to be the most efficient method, supplemented by other energy sources when necessary. Being a direct solar method, this is a great way to use solar power. If space onboard is at a premium, floating passive solar water heaters can be deployed. The disadvantage is pumping costs, however it may be possible to transfer heat through convection.

An important part of the hot water system is insulation. The tank itself should be very well insulated, as should the pipes. A significant amount of the energy in a conventional hot water system goes into warming up the metal pipes, which is inefficient and can be avoided.

35.5 Stove

Cooking is a very energy intensive activity - 1000-3000 watts for a burner, 2500-5000 for an oven, and one which is often done by many people at the same time. Thus it represents the



toughest kind of load for an energy system. Indeed, many home power systems find that food preparation is their heaviest load of the day. As is often the case, we have a variety of energy sources to choose from, solar, electric, fuel (hydrogen, propane, alcohol). Because it's such a high load, we may wish to cook with stored fuel rather than electricity. This fuel can be imported or generated by our power system (hydrogen through electrolysis).

A disadvantage to traditional stoves is that they lose a lot of heat (think about how hot a kitchen gets). Not only does the air carry away energy, but you're heating up a big metal pan along with your food. Microwave ovens waste much less energy, since the radiation bounces around until it's absorbed by the food. For slow cooking, crock pots (which are well-insulated) lose less heat than a big pot on the stove. Unfortunately, these methods of cooking are not suited to nice meals, so we still expect seastead kitchens to be warm on occasion.

Second, cooking requires a very large amount of power and many people tend to do it at the same time. Thus it represents a difficult drain on any energy system. Our proposed solution is to generate hydrogen through electrolysis, which can be done efficiently with commercially available units when there is excess electricity. The hydrogen is then burned in a stove. As discussed in the fuels section, hydrogen is quite safe. This gives us an alternative method of energy storage, which is useful.

35.6 Oven

An oven is a box for holding heat. Modern ovens do a poor job of this (warm kitchens again), and thus need heat constantly poured into them. If we just insulate the oven, it will require a lot less energy. Any method can be used to provide the needed heat. Conventional ovens only have the heating element on 20% of the time

35.7 Washing Machine

As usual, there is the conventional way and the energy-efficient way. Conventional washing machines use 100-230 liters of water per load. When this is hot water, heating costs are a

large part of the total energy use. The Staber washing machine uses only 110 to 150 watt-hours and 45 L water per load [Staber]. This is a little high, but not too bad. The reduced water use has a big impact on energy because it means reduced hot-water use. 2 loads / person / week would be a negligible increase in energy expenditure (+0.04 kWhrs/day) but a significant increase in water use (+13 L/day). We can generate that water from Reverse Osmosis with 0.17 kWh/p/day of electricity. So a total of 0.21 kWhrs/person/day does 2 loads a week (not counting water heating energy). That's well in line w/ our power figures. Another interesting technology is ozone injection. Ozone serves as a better replacement for bleach, works well in cold water, and leaves no chlorine residue. Seasteaders probably won't do laundry as often as on land, this goes with being a pioneer.

35.8 Dryer

There are extremely energy-efficient dryers, such as the Spin-X, which works by spinning clothes very quickly to extract water with centrifugal force. The manufacturer claims that 2 minutes in it is equiv. to 30 minutes in a normal drier. Uses 25 watts for a 3 minute load - not sure if this means 25 watt-hours, or 25 continuous watts which is 1.25 watt-hours, but either way it's negligible. The Spin-X does not get clothes dry enough to replace a traditional dryer, but a much shorter dryer run is then needed [CET].

Alternatively, clothes can be dried the old-fashioned way, by being hung out on lines. One potential worry on a seastead is that they could potentially pick up a little salt spray. Also, they'll dry very slowly because of the high humidity. Given the low energy costs of the spin dryer plus a short heated drying cycle, line drying will probably not be necessarily.

35.9 Dishwasher

High-efficiency dishwashers such as the Fisher & Paykel Dual DishDrawer use about 20 L/load, while normal dishwashers use about 40L. As energy-efficient appliances go, this is a pretty small improvement, but it's still not that much water. Much of this water much be hot, which uses additional resources, but we can get hot water with reasonable efficiency through passive solar installations. Another problem is that one way that efficient dishwashers save energy is by using air drying instead of a heat drying cycle. Unfortunately in our humid environment, air drying may not work very well - seasteaders may need to get out the hand towels and dry dishes the old-fashioned way. A clever dehumidification technique would also help - perhaps a solar dehydrator which converts humid air into water and dry air. The humid air could simply be run through a condenser using ocean water for cooling.

35.10 Vacuum

A vacuum cleaner is a good example of an appliance with an extremely low duty cycle. It may not be very energy efficient, but that doesn't matter. Portable floor vacuums use about 500-1000 watts. If each person vacuums for an hour a week, that's a negligible 0.1 kWhs/week. Similar appliances include power tools (drills, sanders, lathes, saws), ???

35.11 Lighting

There is a large range of energy efficiency for lighting. Three technologies worth mentioning are incandescent lights, fluorescent lights, and Light Emitting Diodes (LED's). Fiber optic light distribution systems are interesting as well.

Incandescent Bulbs

Incandescence was the first electrical lighting technique invented. We think of incandescent bulbs as electric heaters which happen to make a little light. Their efficiency is only 10%, and they last only 1,000 hours. Halogen bulbs are a more efficient, longer-lasting type of bulb, but they still produce a lot of heat.

Fluorescent Bulbs

Fluorescent bulbs have been used for awhile, although only recently in the home market due to the arrival of the compact fluorescent form factor. They are 4-5 times more energy efficient and last 10,000 - 20,000 hours. While they are more expensive, but their cost is well worth the gains - especially on a seastead where energy is expensive. Unfortunately, these bulbs contain lead and mercury, and thus must be treated as hazardous waste or they will pollute the environment.

Light Emitting Diodes

LED's are a newer technology from the solid-state electronics field, which have only gotten cheap and bright enough to be used for large-scale lighting in the past decade. Large numbers of traffic lights, for example, have switched to LED's in the past few years. Because they last so long (100,000 hours), they are the clear choice for locations where replacing bulbs is very difficult. Colored LED's are about as efficient as fluorescent bulbs, but white ones are only half as efficient. Still, future LED's will be more efficient than fluorescents. Unlike fluorescents, LED's do not contain poisonous chemicals.

In the table below we can see the efficiency of each type in terms of how many lumens per watt it produces, as well as the lifetime of the bulb. Cost for the bulb is given per kilo-lumen-year, and electricity cost for the same period, assuming \$0.20/kWh. In general, electricity cost dwarfs bulb cost, so efficiency is quite important.

	Lumens/Watt	Lifetime (hrs)	Bulb cost/k-lumen-yr	Electricity/k-lumen-yr	Total cost/k-lumen-yr
Incandescent	15	750-1,000	\$7 571	kWh	\$121
Fluorescent	60	10,000-20,000	\$14 143	kWh	\$43
LED (white)	25	100,000	\$500 350	kWh	\$570

As you can see, the inefficiency of incandescents and the high cost of LEDs make fluorescents the clear choice. LEDs work well in places where only small points need to be lit, such as emergency lighting strips. They are also better when colored lighting is acceptable, as colored LEDs are cheaper and more efficient.

A neat technology being developed for lighting is the use of fiber optic cables to move light around. These cables are like wires, except they transmit light. One method for using them is a system like the Himawari, which gathers sunlight with lenses, then transmits it via fiber optic cable to wherever needs lighting [Himawari]. This lets us transmit natural sunlight (with UV conveniently attenuated by the system) to deep interior area of the seastead. Another method is to have a main central lamp, and fiber optic cables running to "power" other lamps. So fewer bulbs are needed, and they can be very efficient ones. The main advantage is the elimination of a lot of electrical wiring. This reduces the possibility of fire or electrical accidents as well as requiring less labor to install. It's especially convenient for ferro-cement structures which don't have hollow walls to put utilities in. However, this is a new technology and it may not be suitable for seastead use.

Chapter 36

Facilities

It is worth discussing what facilities are needed and or desirable on a seasteed, as well as what special problems these facilities may pose.

36.1 Infirmary

Being an isolated environment, a seasteed will need some facilities for medical care. The larger the seasteed, the larger these facilities can be. Elaborate trauma, burn, or IC units and surgical facilities will not be possible on smaller seasteeds. Serious injuries will have to be transported to land by airplane or helicopter, which may be dozens to thousands of miles away. Contrary to popular impressions, while quick medical care at the paramedic level is certainly important, the need for quick medical care at the surgical level is rare. People rarely die quickly in ways that could have been saved by surgical facilities, and even serious accidents usually allow enough time for transportation. Paramedic level facilities can easily be incorporated in Seasteed Lite, and perhaps a minimal ER.

One way of looking at medical emergencies on a seasteed is that it is similar to life in rural or remote areas. While urban dwellers may be accustomed to a high concentration of





hospitals, many people, even in the first world, are presented with the same set of options. Deal with it yourself, go to someplace nearby with poor facilities, or face a long drive or expensive chopper ride to a real hospital. Seasteads will have advantages over rural dwellers in that they can guarantee that trained personnel and lower-levels of care are much more accessible than places where the nearest doctor might be dozens of miles away. And seasteads can have airplanes and/or choppers ready, where rural dwellers must wait for them to be dispatched.

If drug laws are lax on seasteads, and especially if drug use is one of the selling points, the infirmary will wish to be prepared for drug-related emergencies, and the staff trained in handling them.

The infirmary will not need much additional infrastructure. It will need oxygen hookups or simply oxygen tanks, which may be able to be refilled during electrolysis. { ?? pressurizing issues ?? }. It will need sterilizing facilities such as an autoclave, and distilled water rather than R/O or rainwater.

36.2 Shop

Part of being self-sufficient is the ability to fix things which break and make new things yourself. Thus a good shop will be necessary. We'll need a small machine shop (lathe + mill + bandsaw + drill press), some welding capability (both arc welding, oxy-acetylene, and probably TIG (Tungsten Inert Gas), and probably some wood shop tools (table saw, radial saw, belt sander). Lastly, we'll need compressed air for a bunch of compressed air tools.

Shops tend to be noisy and sometimes smelly, and they should be located with that in mind. We'll also need to conserve space, so we may want put the tools on wheels, they can be stored in a compressed format when not being used. There will not be enough room to have all the tools out in a static layout. Instead, they will be moveable, and we can deploy whatever set is necessary for the current job.

It may be useful to have a small foundry as part of the shop. Whenever some tool is needed, it can be rough cast out of aluminum, and machined to final form. When the tool is no longer needed or breaks, it can be thrown back into the scrap heap, melted down and reused. All hand tools such as shovels, rakes, screw drivers, etc. would be candidates for this level of reuse. This allows a modest amount of metal to be reused over and over again.

36.3 Kitchen

Anything to say? Energy efficient appliances (if frequently used), small space, efficient storage.

36.4 Common Areas

{ Does this seem like a good place to have a discussion of "community"? - P }

A seastead will consist of like-minded individuals sharing a small space, thus it will be a community. Having many facilities be communal reduces their cost and the space used. The land-based pattern where everyone has their own kitchen, their own tool shop in the garage, their own TV/movie setup, their own boat and so forth is just not suited to seastead life. Fortunately, as with many of the problems we face, we can draw from solutions which other groups are finding in other contexts.

The Cohousing and Intentional Communities movements have been experiencing a resurgence in the past few decades. Cohousing started in Europe and has been spreading to the US. ?? The FIC listing has hundreds of communities in the US??. This movement has experience in architectural designs which provide reasonable and efficient combinations of private and public space. The CoHousing Company [ref], located in Berkeley, CA, USA, offers advice on all stages of community creation. We feel that it would be desirable to hire them as consultants on the interior layouts and designs of the seastead. They are used to working alongside traditional architects and engineers, although working with marine engineers may be a new experience.

Seasteams whose residents are paying first-world prices will certainly be able to have private space for individuals. (If poorer people wish to seastead, they may not get private space, which is a sacrifice that they will need to make, and may be used to making in their land-based life.) However, especially with early seasteams, most facilities will be shared. Kitchens, lounges, workshops, gardens, and so forth will all be common. This has some definite advantages. It should be easy for a seastead to amass quite a large library of movies and music, for example.

Chapter 37

Government

{This section is brand new, and thus rough}

A government is the social infrastructure for a nation. Since one of the main purposes of seasteading is to allow people to experiment with novel forms of social organization, we can't exactly list all the possibilities (although we'll mention a few). Residents can try whatever floats their boat. Instead, we'll try to focus on the unique aspects of seasteading which will affect the design and function of its government. These include:

- Small, isolated community.
- More homogeneous opinions - since the population is small and self-selected, they may be united behind some philosophy.
- Autonomy.
- Built from scratch.
- Dynamic geography.

The most consistent result of these factors is simply that we can expect a great variety of forms of governance. For example, homogeneity of viewpoints allows for more extreme or experimental systems that a diverse group would never agree to. Environmentalists could adopt strict regulations on the emission of greenhouse gases. Libertarians could have an extremely minimal government. Religions could enshrine their beliefs as law. Because the group is like-minded, they can agree to these unusual policies.

Having the autonomy to pick a new system has the same effect. No longer are residents bound by some previous constitution. Same with the "from scratch" nature of seasteads. Since each new platform is potentially a sovereign entity, each new set of residents, if they want, can design an entirely new system. The thesis of dynamic geography points the same way. Having a lower barrier to entry in the governance market will result in a much greater variety of products.

The rest of the world may see these systems as strange or idealistic. But as long as residents joined voluntarily and are free to leave, we say more power to them. Time will separate the foolish from the innovative.

As the number of platforms and multi-platform cities grows, we can expect competitive pressure to improve the quality of government at all levels. Good ideas will be imitated and bad ones discarded, since new residents will be more attracted to systems that have proven effective.

The government of multi-platform communities is likely to be much more limited than that of individual platforms. It will tend to focus on intra-platform issues such as infrastructure, easements, local pollution, legal arbitration between different legal systems, and interactions with the outside world. If it grows more intrusive than individual platforms desire, they'll break off and start a new group.

Because initial communities will be small, they will not be able to afford many full-time personnel. This means that many public-sector jobs such as militia, police, emergency response (first aid) will be done as secondary professions by members of the community. This encourages a community of peers, rather than one which supports a special class of public servants.

{ Talk about who owns the seastead? ie residents equally, residents unequally, some development company, etc. Proprietary community, democratic community, CIC... }

37.1 Universal Human Rights

There is a great deal of debate about human rights. Libertarians believe in the right to not be harmed or threatened by violence, while those on the left believe in the right not to starve or go without health care. The United Nations even made a Universal Declaration of Human Rights back in 1948, which included the right not to be enslaved (Article 4), or tortured (Article 5), the right to property (Article 17) and freedom of thought and expression of beliefs (Article 18).

Of course, when it comes to the details, there is much room for disagreement about what the UN's sweeping statements mean, and whether current states abide by them. For example, Article 17.2 states "No one shall be arbitrarily deprived of his property.", which seems to conflict with the eminent domain practices of the US which came to light in *Kelo vs. New London*. And Article 18 says that "Everyone has the right to freedom of thought, conscience and religion; this right includes freedom to change his religion or belief, and freedom, either alone or in community with others and in public or private, to manifest his religion or belief in teaching, practice, worship and observance." Yet Europe's numerous censorship laws about Holocaust denial and Nazism certainly serve to prohibit the teaching, practice, and observance of certain (very stupid) beliefs.

However, we don't want to be too hard on the UN declaration. It may be a bit broad, but based on the ideas we espouse in this book, we see Article 13.2 (or at least, the first half), as the true essence of freedom, the single right on which all others are based:

Article 13.

(1) Everyone has the right to freedom of movement and residence within the borders of each state.

(2) Everyone has the right to leave any country, including his own, and to return to his country.

A little modification and extension gets us the following, which we propose as the fundamental, universal human rights:

Universal Human Rights:

(1) Everyone has the right to leave any country, as long as they are not fleeing significant outstanding obligations.

(2) Everyone has the right to create a country, as long as joining it is voluntary.

The dynamic geography theory gives us the first line of reasoning about why these rights are so important. Viewing governments as service providers, being able to switch providers and avoid lock-in is key to making sure a provider doesn't exploit its customers. Everything else flows from there. As long as you can create new providers and switch to them, then current providers can't screw you too badly. The worse they treat their customers, the more incentive there is for a new provider to join the fray.

The idea of the social contract, ascribed to Hobbes and Rousseau, is also key to our concept of human rights:

The term social contract describes a broad class of philosophical theories whose subjects are the implied agreements by which people form nations and maintain a social order. In laymen's terms, this means that the people give up some rights to a government in order to receive social order. Social contract theory provides the rationale behind the historically important notion that legitimate state authority must be derived from the consent of the governed.

While many libertarians do not support the social contract, because it affects their natural rights, we have a different approach. Given how much disagreement there is about what rights are natural, a system based on natural rights seems problematic. We don't see people's different conceptions of rights as a problem to be solved by proselytizing and argumentation, but an empirical fact about the world to be dealt with. And we think the best way of dealing with it is a system where different groups of people with different concepts of rights and what makes a just society can get together in voluntary association and live as they think best. Which is, of course, what seasteads are for.

The problem with the social contract is not the general idea of people getting together to form a society, it is that the practice of that idea is quite different. As Hume said in "Of the Original Contract", the contract theory of government is not supported by available historical data [wikipedia]. What we mean is that people do not voluntarily sign on to an explicit social contract. Instead, they are born into a country which claims sovereignty over some large area of land and set of people, and forced to follow its rules. They have few alternatives, and it is difficult to create new ones. They grow up, become of voting age (if in a democracy), and end up becoming part of the social contract implicitly. As Hume says:

Should it be said, that, by living under the dominion of a prince which one might leave, every individual has given a tacit consent to his authority, and promised him obedience; it may be answered, that such an implied consent can only have place where a man imagines that the matter depends on his choice. But where he thinks (as all mankind do who are born under established governments) that, by his birth, he owes allegiance to a certain prince or certain form of government; it would be absurd to infer a consent or choice, which he expressly, in this case, renounces and disclaims.

Can we seriously say, that a poor peasant or artisan has a free choice to leave his country, when he knows no foreign language or manners, and lives, from day to day, by the small wages which he acquires? We may as well assert that a man, by remaining in a vessel, freely consents to the dominion of the master; though he was carried on board while asleep, and must leap into the ocean and perish, the moment he leaves her.-

Like Hume, we don't buy the argument that staying in a country is equivalent to signing the social contract and signifying acceptance of all the rules of the country. However, we find the general concept of the social contract quite appealing. People want to organize in groups which give up some rights and protect others, and they should be free to do so -

but let's make it explicit. Let's also make it explicit that they must be allowed to change their mind and leave later, so that no social contract becomes too burdensome, or reaches the point of enslavement. And let's also make it explicit that there must not be a cartel of nations, but that people must be free to start new ones.

This idea stands in stark contrast to Rawls' original position, which involves finding a social contract that one would agree to from behind the "veil of ignorance", where one has no idea what one's position in society will be. While the original position is an interesting theoretical device, it is impractical if not impossible to act in supposed ignorance when actual social contracts are entered into and enforced by actual people who know their actual position in life. In the real world, the veil is transparent. So our approach is to let real people who know their position in society, their abilities and preferences, and their experiences with existing societies, to find and enter into the social contracts which they think would best suit them.

We believe that giving primacy to the right to choose one's social contract, including creating a new one, cuts through the unresolvable tangles of determining exactly what universal human rights are and what type of society is just. As long as people can voluntarily join and leave groups, we have neither the right nor the need to judge the details of how those groups organize themselves and define their rights. We seek neither the right to dictate how other people should live, nor for the burden of figuring out how to make utopia, but only that each of us may live as we see fit. This seems much more achievable than converting everyone to the One True Philosophy, whether it be Rand, or Rawls, or whatever.

While we think that this idea simplifies much political philosophy, it is of course not a magic bullet. Difficult questions still remain about when an individual's right to choose a contract are being violated. People should not be able to just run away from trials or judgments, but a country may levy enormous fines on someone, and say they cannot leave until they are paid. Furthermore the whole area of conflict between countries is not addressed by this Universal Right at all - and it is a morass in its own right.

Still, we find it an enormous relief to realize that we can just throw up our hands and safely leave some of the questions philosophers have been discussing for millennia unresolved. We just want to create a laboratory for experimenting with social contracts, and a world in which people are free to create societies with groups of like-minded compatriots. The details of those societies are up to you.

This idea even extends to the nation of a Universal Right to free association. We, the authors of this book, don't get to dictate what events will cause seasteads to invade each other - or call for terrestrial countries to intervene. Just as each seastead can set its own internal rules, each seastead can set its own rules for when (if ever) to interfere with other seasteads. You must make your own decisions - it's turtles all the way down.

37.2 Government By Corporation

Many people assume that replacing a democracy with a corporation would be a terrible thing, yet there are strong arguments to the contrary (I get much better service at my Honda dealer than the DMV). Mencius Moldbug, a political blogger who writes about competitive government at Unqualified Reservation, makes the case for a joint-stock republic:

The joint-stock republic is a very different entity from your ordinary, democratic republic. Its shares are negotiable and freely traded. Owning a share is not a "right," except in the sense that if you own a share of Intel you have a right to receive Intel dividends. And, most importantly, the republic is operated for

the exclusive benefit of its shareholders. All corporate governance mechanisms are otherwise the same, although without a superior sovereign to enforce them they must enforce themselves. Briefly: combine this technology with this one. (Those Google engineers will be busy.)

If the republic is operated for the exclusive benefit of its shareholders, who of course are likely to resemble the corporate shareholders of the present day (pension funds, fat cats, Saudi sheikhs, etc), how on earth does it provide high-quality government? Shouldn't it be operated for the benefit of its customers?

This is the miracle of capitalism, so familiar and yet still so strange. The capitalist restaurant is operated for the benefit of its owners. The Communist restaurant is operated for the benefit of its customers. But which has better food?

We must agree that a restaurant operated effectively for the benefit of the customers will be a better restaurant than any operated for the benefit of the owners. But it is not possible to design a management structure that will reliably achieve this result. The problem is fundamental: we cannot state a precise and unambiguous definition of "good food" that we know all customers will agree on. We cannot characterize the results objectively or quantitatively.

We can, however, operate a restaurant effectively for the benefit of the owners, because we can describe what the owners want objectively and quantitatively: money. The more, the better. Thus the restaurant can be accountable to its owners, as it never can to its customers. And it is this accountability, this quality of tautness, which causes it to serve its customers well. A string can be loose in many ways, but tight in only one.

In a joint-stock republic, the mapping from profitable ownership to high-quality government is straightforward. The return on each share is a function of the value of the capital. The capital is the country, ie, its real estate. The value of real estate is its price. How does a government maximize the price of its real estate? By making the country as pleasant a place to live as possible, ie, by providing high-quality government.

CEOs of private corporations today may be effective or ineffective. There is no escaping the bell curve. On the right end, you have Steve Jobs; on the left, Gil Amelio. However, one quality shared by almost all corporate CEOs is sanity. One generally does not hear of them going crazy and murdering the entire board of directors with a fire-exit axe, or the like. I realize that this is a low standard - but consider the record of heads of state in the democratic era.

While this form of government may not satisfy everyone - such as those who place a high value on democratic participation in the political process - the more libertarian, capitalist oriented segment of the seasteading populations believes it has substantial advantages and is well worth a try. Everyone else can steer clear, and see how it works out.

37.3 Polycentric Law

Need a brief case for / introduction to (if that is possible) polycentric law / market anarchism / ancip. (Can we get a volunteer to write it, or quote some article?)

Chapter 38

Waste Disposal

Disposing of trash is yet another area which requires special consideration onboard a seastead. Since storage volume is limited, landfills and dumps are not viable options. As astronauts have discovered, trash takes up a lot of room. Mir generated a ton of trash per month [SpaceTodayFactoids], and Skylab had around 1/3 its volume set aside for waste collection and storage [SkylabFirst, Ch. 2].

Because improperly handling trash imposes costs on others, waste disposal is a political issue as well as an engineering one. This magnifies its importance. Strange though it may seem to ruminate about rubbish, we see this smelly segment as being worth at least as much consideration as food, power, or water.

38.1 Types of Waste

Lets take a look at some kinds of waste:

{ Check sources for correctness and better descriptions. Is a DL the right structure to use here? It looks kinda funny. - P }

[
](images/beet_leaves_big.jpg)Organic Waste

Inedible vegetable material like stems, leaves, and seeds, which still contain organic nutrients.

[
](images/toilet_big.jpg)Human Waste

Humanure contains nutrients, but since it can contain pathogens it requires treatment to be safe.

[
](images/biohazard_big.jpg)Hazardous Waste

Toxic chemicals and biohazards need to be dealt with carefully.





[
](images/recycle_logo_big.jpg)Recyclables
 Glass, plastic, metal, or anything else that can be recycled effectively. Limited recycling may be done onboard, with the remainder sold to land-based operations.

[
](images/trash_bags_big.jpg)Misc. Waste
 Trash which does not fit into the above categories. Combustible miscellaneous waste may be useful for generating heat.

As you can see, waste may contain positive, negative, or neutral value. For example, organic waste contains fertilizing nutrients we can use to grow food. The hazardous waste contains toxic substances which we should not let into the environment to harm others. The miscellaneous waste we just want to get rid of. Because of these differences, the best solution is to use several disposal methods in tandem.

The table below contains detailed data on the composition of municipal american waste in the 1960's. While this will likely be different than the composition of waste on a seasteed, it's a start. There is also some less detailed data on municipal solid waste in 1990.

(INSERT TABLE)





38.2 Disposal Methods

There are a number of different disposal methods, which we'll go into in some detail. However, we should not forget avoidance and recycling as methods for reducing waste. The hierarchy of solid waste disposal is "Avoidance -> Recycling -> Energy Recovery -> Landfilling", as described in this environmental engineering book:

- The best option is to avoid creation of the waste material. Obviously, we cannot eliminate the generation of solid waste. However, there is ample opportunity to significantly reduce the amount of waste created...The second best option is to recycle unwanted materials rather than disposing of them...The next option is to use the waste materials for energy recovery by use of a solid waste incinerator that produces usable energy. Landfilling is the least desirable option.... [Ray1995, p. 348]

Shipping to Land

If all else fails, a seastead can ship waste to a dump on land. After all, that's what most of the first world does with their trash. If care is taken to avoid waste generation (ie removing bulky packaging on land before transporting goods), this might be effective. One may question the wisdom of piling trash on land when it could just be piled on the ocean floor instead. But remember that the latter seems more like polluting a common, which we want to avoid for political reasons. Shipping is a pretty good way to deal with hazardous waste that existing facilities deal with, but we can't easily process ourselves. Hazardous waste which requires long-term storage might as well be shipped to land also - they have a lot more room. There are better solutions for most other types of waste, but we should keep this in mind as a safety net.

Dumping

The easiest method of waste disposal on the ocean is simply to dump the unwanted refuse over the side. This technique has been used by humans since they first became seafarers. In fact, it has been the standard on earth since primordial life evolved in the oceans, and is still used daily by millions of creatures. Fish excrete, and since their waste products are heavier



than water, they sink to the ocean floor. Natural upwellings eventually stir it back up, and it nourishes the microscopic creatures which form the base of the marine food pyramid.

For many types of waste, however, dumping is problematic. Some waste contains valuable materials (ie nutrients in organic waste). Rather than throwing them away, seastealers can recycle these back into their own food chain. Poisoning the ocean by dumping hazardous waste is immoral and irresponsible. It is possible that proper sealing could render hazardous waste safe, but this is getting into a grey area. Waste which is lighter than seawater would accumulate on the surface and eventually wash to shore, which is undesirable. Bays and coastal areas, especially close to populations, have (by necessity) strict rules about dumping. Finally, as discussed in more detail later, there are important political considerations which weigh against dumping. Certain kinds of dumping are regulated by UNLOS.

Given these caveats, dumping will probably be an appropriate disposal method for a few types of waste, ie biodegradable / inert and not worth recycling.

Incineration

Incineration is probably the second oldest form of waste disposal, dating from the time when man found that he could warm himself by burning the things he had hitherto dumped outside his cave...Nomadic groups...have ignored the consequences of open waste dumps. Fixed communities cannot.

Municipal incineration began in England in 1874, and by the 1920's it was the only large-scale method of disposal used in the country.

- [Corey1969, p. 1-3]

Incineration is used for approximately 10 to 15% of all municipal solid waste. Industry and government have accepted burning as a preferred disposal method for many solid and hazardous wastes - that is, compared to landfilling. Incineration destroys the toxic organics in waste in a matter of minutes or seconds, whereas those chemicals might lie for decades in a landfill, or, worse, migrate to groundwater...incineration presents other advantages. It uses an otherwise worthless material to produce energy and it can vastly reduce the volume required for landfilling...The biggest problem in solid waste incineration now is

public opposition. Because incinerators produce small amounts of air pollutants, a segment of the public invariably opposes them...Most municipal solid waste incinerators do not have air pollution control equipment. -

[Ray1995, pp. 380-381]

Incineration, which reduces waste into its base components, has a number of advantages:

- Destroys toxic chemicals. For example, it is the only method approved by Congress and the EPA for disposing chlorinated organics [Ray1995, p. 413]. Incinerators are the preferred disposal method for hazardous wastes whenever possible [Ray1995, p. 403].
- If the waste was organic, the resulting ash can be used to enrich a hydroponic nutrient solution.
- Combustion generally results in net energy output, which can be used directly to heat or desalinate water, or turned into electricity.
- Its speed keeps smelly garbage from piling up.
- Greatly reduces the size of waste (ash is typically a few percent of the volume and mass of the original waste).
- Renders even human waste safe, if performed properly.
- Scales very well.
- About one-half of the solid waste in urban areas, and two-thirds (by weight) of the waste from homes can be disposed of by this method [Corey1969, p. 6].

There are some drawbacks to incineration. It is important to know what substances are being incinerated to ensure that toxic fumes are not being released. Combustion does add to the carbon in the earth's atmosphere. However, initial seasteads will be miniscule producers of greenhouse gasses compared to current cities because of their general energy-efficiency. Devices can also be used to reduce the pollution emitted, such as filtration, settling chambers, wet scrubbers, and electrostatic precipitators [Corey1969, pp. 48-66]. The pollution released by an incinerator depends greatly on its design, and so environmentally-conscious seasteaders can choose one which fits their desires. Incineration will sometimes require significant energy input, depending on the waste. Dehydration will probably be a necessary preparation step, as vaporizing water takes a lot of power. In fact, dehydration has been used as part of the incineration process since at least 1901.

It may well be desirable to use a separate incinerator for organic waste, to ensure that the nutritive ash is not contaminated by toxic substances like heavy metals which are not destroyed by incineration. There are several small-scale incineration systems with specifications and prices available on the web. While this list is by no means comprehensive, it should give you a quick idea of what is available. (Click on an image to go directly to the manufacturers website.)

[SmartAsh]

This is a non-hazardous waste incinerator which can handle organic waste, paper, plastic, packaging, oil and so forth. Requires no fuel, but draws 0.8 kw/hr to power its fans. Burns 50 lbs/hr of waste. Costs about \$3000.

[MediBurn]

This small incinerator is designed to dispose of hospital waste, including infectious and pathological waste. It is thus suitable for handling human waste. It uses 0.35 Kw and 5 gallons of fuel per hour. Handles 8 ft³/load (not sure how long a load takes). It is fuel intensive, but still reasonable for dealing with feces.

[Incinolet] An electric incinerating toilet, so it's an incinerator specifically designed to deal with human waste. Requires the use of a liner each time, and uses 1.5 kWhs / cycle. This is a lot, but probably feasible for feces only. Costs approx. \$1700, and is easy to install as it requires no plumbing, only a vent.

[EcoWaste] This larger line of incinerators from Eco Waste Solutions can handle 300lbs - 25 tons / day of municipal waste, hospital waste, and oil using a two-stage pyrolysis system.

Incineration is an excellent method of destroying many types of hazardous waste, but has significant drawbacks for organic material. Organic ash is high in trace elements such as metals, which are concentrated by incineration. Plants like these in small amounts, but they are poisonous in large amounts, so the ash must be used cautiously. The organic matter and nitrogen - important nutrients - are destroyed. So while incineration is better than nothing for organic debris, it is still inferior to our next option.

Composting

In nature, leaves fall to the forest floor and are gradually decomposed by a variety of microorganisms including fungi, bacteria, and protozoa. This degradation process returns the nutrients contained in the leaves to the soil where they become available again to the trees and other vegetation. In contrast, leaves falling in cities become a solid waste...Composting, which is the controlled aerobic partial degradation of organic wastes, produces a material that can be used for landscaping, landfill cover, or soil conditioning.[Ray1995, p. 359]

Composting is a tried and true method of converting organic wastes into plant food. The waste is simply left in a pile for microbes to digest, just like in the natural world. It is desirable to either mix or create trapped airspaces so that the compost is exposed to oxygen. This is because anaerobic conditions produce offensive odors and potentially dangerous gasses (although methane rises, so it will escape). Composting preserves more of the nutrients than incineration, and can be used to turn even "humanure" into safe compost. The process even breaks down many types of toxic contaminants, such as organics (though not heavy metals) [Jenkins1999].

While effective, composting is a slow process, usually taking months (1-2 years for humanure), and so it requires a lot of space to store the waste during that period. Space is at a premium on board, so this is a significant disadvantage. (This can be partially addressed by placing the compost area in one of the lower spar chambers, out of the way). Not all materials are suitable for composting, depending on factors like the carbon/nitrogen ratio.

Many seasteads are likely to favor composting over incineration for the disposal of organic waste, and set aside the necessary space. However, others will simply stick to incineration.

Compacting

Compressing any waste which is going to be stored or shipped saves a lot of space. It also reduces odor, since most smells stay trapped inside the solid block. Low-pressure compaction results in densities of 700-1000 lb/ft³, and high-pressure can create densities of 1600-1800 lb/ft³ [Ray1995, p. 367]. it's an easy win.

Recycling

It may be possible to recycle some materials onboard (glass, aluminum, plastic). While it takes a high temperature to melt metal or glass, remember that with better insulation, less energy is required to produce a given temperature. Also, we can more efficiently recycle bottles by washing, sterilizing, and re-using than by using them as raw materials for new bottles [Ray1995, p. 51-352]. In large communities on land, this is problematic because bottles may have had toxic substances stored in them. However in a smaller and more conscientious seastead community this method should work well. Even if the seastead itself does not process a potential recyclable, the material can be compacted, shipped to land, and sold to a recycling plant.

Unfortunately recycling is often inefficient, in part because it is kluged onto existing systems. *Cradle To Cradle*[McDonough2002] suggests that recycling is better accomplished by re-designing our materials so as to be easily reusable. In the miniature economy of a platform, this may be practical, and could even be the motivating philosophy for an entire group of seasteaders. It would certainly be an interesting experiment.

It is more likely that the production and purchase of goods will simply be tailored with the expense of waste disposal in mind. Bulky packaging is a response to how cheap it is for the producer to buy the packaging and the consumer to throw it out (or, according to some, because many of the costs are born by others). This difference between terra aquatica and terra firma may cause some difficulties (as when goods imported in large quantities have a lot of packaging). Still, we are quite confident that the seastead economy will adapt to the incentives it faces. Vegetables from the greenhouses won't come in plastic bags. Soda will be imported as a concentrated syrup, not in cans. The same glass bottles will be sterilized and re-used for each batch of homebrew.

Thermal Depolymerization

Fossil fuels were created over a long period of time by geothermal processes acting on organic waste. An industrial process which mimics this has recently been developed, involving several stages of heat and pressure changes. It is both rapid and fairly efficient (85%). Changing World Technologies has employed it in a pilot plant in Pennsylvania and a commercial facility in Missouri. In the latter facility it converts waste from a Butterball turkey plant into fuel. While the procedure is not really suited to small-scale waste processing, it shows great promise for dealing with large quantities of waste [ThermalDepol].

Hazardous Waste Treatment

For hazardous wastes which are not destroyed by incineration, other methods may be necessary. Precipitation, coagulation, filtration, neutralization, oxidation, reduction, chemical fixation, and adsorption are some of the techniques used [Ray1995, pp. 407-410]. It is unlikely to be worthwhile to use these methods to process occasional hazardous materials encountered in the waste stream. However, there will eventually be manufacturing and industrial processes onboard which will generate predictable and specialized hazardous waste. At that point, specialized treatment facilities are appropriate.



38.3 Political Considerations

A nation's methods of dealing with its waste are seen by others as symbolic of its nature, at least to some degree. This is quite reasonable. Most of the effects of most policies are internal to a nation (ie crime laws), or positive for the rest of the world (ie production and trade). Pollution is external and negative. An example of the importance of waste disposal policies is the international outrage over the US refusal to sign the Kyoto Protocol. However one feels about the merits of the proposal, it is noteworthy that it has prompted more indignation than some of America's bloodier and more objectively tyrannical actions.

Thus dirty disposal methods like dumping, while cheap and easy, are problematic. The argument that seasteadingers should be left alone to pursue their unique lifestyle in peace, while harming nobody, is a good one. But it does not hold up when costs are being imposed on the rest of the world (what economists call *externalities*). While seasteadingers and terrestrial nations are likely to quibble endlessly about exactly what constitutes an externality, pollution is a clear faux pas.

Seasteading will start with a tenuous position in world politics, so it behooves them to be good global citizens. In the twenty-first century, this means clean waste disposal practices. While many corporations and governments get away with pollution, they are the world's elite. The oceans are seen as the common property of humanity - occupation may be tolerated, but befoulment will not.

Considering the opinions of customers rather than nations, we get the same result. Greenness is part of the appeal of seasteading, and avoiding negative externalities (not polluting) is a core part of the green philosophy. Serving a niche market can be good business, but alienating the majority of your customers is a recipe for failure.

These considerations make waste disposal a surprisingly crucial part of a seastead's infrastructure.

38.4 Polluters

The problem, however, will not go away so easily. Later seasteading will be in a less tenuous political position and, facing competition with other platforms, may have a stronger desire



to cut costs. Once there are enough platforms for populations to segregate, there will be seasteads without strong sentiments against pollution. However, the difficulty of getting caught polluting the oceans will prove an irresistible temptation to some. It is inevitable that a stead will pollute, and eventually be caught doing so. This will reflect poorly on the entire movement.

Unless the rest of the world has changed dramatically by then (which seems unlikely), the simplest response will be to point out that land has its share of polluters as well. As one source points out:

It is really quite easy to get carried away with the environmental security issue. It has immense popular appeal, it has a sense of urgency that can be exploited, and touches the consciences of those who enjoy a high standard of living. However, it should be borne in mind that **80 percent** of marine pollution stems from land-based sources, including run-off, air pollution, and coastal development.

As always, utopia is not an option, and it is unfair to compare this (or any) way of life with an impossible ideal. The important question will be: how do seasteads compare with the rest of the world in the pollution department? We expect that clean power generation, the need for efficiency, and the influence of green philosophy will render a satisfactory answer for the majority, though not all. Any malfeasors must face the consequences of their actions.

38.5 Environmental Regulation

Some seasteads, to demonstrate their cooperative membership in the global community, may become parties to environmental treaties. Even if these seasteads do not have the status of nations, such accords are statements of intent, and so there is little reason to exclude private entities. The outside world may impose regulations on seasteads, acting in lieu of their nonexistent central governments. Groups of connected platforms will certainly have environmental agreements as part of their contracts, since they share air and water. Geographically disparate platforms may have agreements as well, to demonstrate a shared

philosophy to themselves and to the rest of the world. They might even contribute to investigations for rogue polluters, who besmirch the reputation of the movement.

This is a good example of how, just as with many other aspects of the seasteading lifestyle, there will be rules and compromises. Don't extrapolate from that and think this new way of life offers no improvements on the old. Rules and compromises are part of reality, and anyone who thinks you can get along without them is a crackpot. We still think there are plenty of incremental improvements available on this side of la-la land. { is this funny or a stretch? - P }

38.6 Example Waste Systems

Here are a few examples of waste disposal systems used on similar facilities: { Other good examples? }

ResidenSea

This cruising condominium apparently uses the following method: *"Contributing to the success of The World's recent ratings is its unique Scandinavian waste water cleaning system, whereby wastes are filtered by a flotation system. Solid wastes are dried and incinerated, and the ash is properly disposed of on land. The remaining liquid waste goes through an ultraviolet filtration process, and the resulting water is as pure as technical water. The World also burns marine diesel..."*ResidenSea

38.7 Waste Summary

A good waste disposal system will use a variety of techniques, cause little pollution, and recover materials and energy from waste when possible. Incineration is the preferred method of disposal for hazardous wastes, organic wastes, and combustible miscellaneous waste. The ash from organic waste will be used for nutrients. Somesteads will choose to use composting for organic waste instead, feeling that it is worth the extra space in order to preserve more nutrients. Recyclables should be re-used intact if possible (ie sterilizing bottles), processed onboard if that is cost-effective, or compacted and shipped to recycling plants on land otherwise. Hazardous waste which cannot be incinerated will likely be shipped to appropriate storage or treatment facilities on land. It may be processed onboard in some circumstances, particularly when it is consistently generated by some onboard process. Some very special kinds of waste (non-combustible, non-toxic, non-floating, non-recyclable, non-nutritive) may be simply dumped into the ocean, although it's hard to think of much which meets these requirements (big rocks?).

Part VII
Making Money

Chapter 39

The Market

*"If this country is worth saving,
it's worth saving at a profit" -
H.L. Hunt*

Many projects dream of some extremely rich person coming along, seeing their proposal, and saying "Neat - to whom do I write the check?" In reality, seasteads are much more likely to happen if somebody can figure out how to make a buck with them. If floating cities are worth building, they're worth building at a profit. And if they can't be built profitably, it is far from clear that they are worth building. This section outlines some business and customer possibilities for seasteads.

It's very important to be honest about the advantages and limitations of doing business on board a floating platform. We've seen numerous proposals for ideas to make money on floating cities that are obviously not going to work, because they don't leverage any of the comparative advantages. There are lots of people out there who want to make money, and there is no easy way or magic recipe to do so. By moving a business to the ocean, you are cutting it off from resources and customers, making everything more expensive and more difficult. To be able to compete with the possibility of doing the same thing on land, there has to be a damn good reason why the ocean is a better place.

After a fair bit of thought, we've only come up with two unique features of seasteading which provide its competitive edge. The first is the freedom offered by sovereignty and the second is the unique ability of seasteads to provide some of the comfort and stability of land in remote marine locations. Hence any business must center around one of these features.

The fundamental seastead business is that of manufacturing, and perhaps operating, the seasteads. We think the best way to characterize this industry is as real estate development. The main differences from conventional development are that the land must be built instead of made, and the developer must provide all utilities rather than just paying for a connection to the grid.

An example of a similar business is a company called International Marine Flotation System Inc. They design and build floating homes, marinas, restaurants, docks, and roads based on concrete floats. They've even built entire floating home developments. A seastead manufacturer would be in a similar business, but geared towards constructing more isolated and self-sufficient real estate.

One nice thing about this version of the real estate business is that it's in some ways less speculative than on land. A land developer must often risk a large chunk of money on a

piece of land or a building. Because seasteads are modular and expandable, the developer can start small - like building a skyscraper a few floors at a time. If successful, profits can be rolled into further expansion. Since there is plenty of room on the ocean, this means no ceiling to the potential profits from the initial stake. This goes a long way to making up for the uncertainty due to the novelty of the seastead business [Hunting2001].

While we're going to present a number of business ideas to demonstrate why this real estate is potentially valuable, the seastead developer should not be specifying its exact set of tenants in advance. Just like the builder of a skyscraper, it's important to know something about potential customers (that they exist, their utilities needs), but there's no need to micro-manage. The seastead builder should be in the real estate business, not the fishing, banking, or medical research business. As Eric Hunting says: "The business plan is straightforward because everything revolves around creating habitable space, the revenue it produces in rent, lease, or sale, and the costs accrued in maintaining it, making it useful, and making it attractive. "

Chapter 40

Business Models

{ There are enough of these that it's probably worth grouping them into sections }

{Merge in customers from below}

{Add a section for our recommended combinations}

Seastead Construction Corp.

At some point, there will be enough groups of people that want a seastead, for whatever reason, that it makes sense to form a corporation that specializes in building seasteads to order. The corporation would not worry about the day-to-day operation of the seasteads it produced. These groups may be interested in residential seasteads for political freedom, or they may be developing one of the many business ideas we propose.

The residential groups can be roughly partitioned into political groups (e.g. libertarians [Atlantis1994], socialists, communists, etc.), religious groups (e.g. fundamentalist Christians, Muslims, etc.) , and single issue groups (e.g. drugs [Island], nudists, gun enthusiasts [FrontSight], environmentalists Celestopia, etc.) While sometimes these groups can legally form their own land based communities, they may prefer to do so in a more isolated environment like a seastead to avoid hassles with local authorities. Some of these groups will have no legal land based option available to them, so something like a seastead will be their only





option. Essentially seasteads would function as intentional communities, with far greater independence and autonomy.

Luxury Resort

{Restructure this as Resort w/ subsections, cruise ships, timeshare, drugs, etc.}

The luxury resort business is thriving [stick a few refs here, maybe a pretty graph]. While many resorts try to leverage some local community or artifact, there are others that merely exist to provide a complete experience unto themselves. For example, many people go to Club Med(tm) and cruise ships with no real intention of ever leaving the facilities. A luxury seastead resort could be tailored to meet the needs of these people. Note that a luxury resort seastead would have to compete with the existing luxury resorts. Thus, issues of how to get to and from the seastead, providing amenities, etc., all have to be worked through. A seastead can offer some experiences that may not be possible at other Luxury Resorts, and these may be the key to its success.

An example of a resort tailored to a specific, freedom-oriented issue is the Front Sight Firearms Training Institute in Nevada. Besides offering training in the use of firearms, as well as similar topics (chemical agents, climbing and rappelling, and soon executive protection), Front Sight's plan is to become a luxury resort for gun lovers. Around a third of the 170 1-acre home sites have already been sold as part of a package which includes a lifetime membership in the training facility. Condominiums and a hotel are planned as well. Front Sight is expanding rapidly with the income stream from its members, and seems to have found/created a successful (and previously untapped) niche market.

The United Arab Emirates are pursuing an extremely large, ambitious, expensive project to build an ultra-luxury resort called The Palms. What is interesting about this particular project is that it is being built entirely on the world largest man-made islands. In fact, the islands will be visible from the moon with the naked eye, and will create 120 km of shoreline. Construction began in 2001 and is expected to end in 2007. { I've been to their webpage but I couldn't find it, need a reference and info on cost - P }

Can a floating luxury resort be profitable? The answer has been yes for decades, as we can see by looking at the cruise ship industry. This ships produce nothing, import all their food, water, and fuel, and still turn a profit. About 10 million people a year take a cruise, providing about \$17B in revenue. Clearly a floating resort can be a profitable business model. This is not to say that it will be easy - cruise ships actually take people places,

which is an advantage. But seasteads can provide some other things to offset that.

Sin IndustriesA seastead is the ideal setting for the so-called sin industries like drugs, prostitution, and gambling. Drugs are low-capital and high-profit, but also carry a great political risks. Still, European countries are relatively tolerant, and as long as drugs are only used locally, the idea may fly. [insert drug stuff from elsewhere].

Prostitution, as long as it does not involve children, is widely accepted. It is at least claimed that some tourism to Thailand and Costa Rica is motivated by cheap prostitutes. Gambling is also widely accepted. While gambling is common enough that it is unlikely to motivate visitors, having it adds substantially to a resort's bottom line.

Timeshare Resort

Timeshares are in between an intentional community and a hotel resort. The residents are owners, but they do not stay there all year. We believe this has some major advantages in terms of financing and market appeal. With financing, time share residents pay up front. Thus you don't have to get a loan with the hope of having enough business to pay it back. You let people buy shares, and when you've sold enough, you start construction.

In terms of the market, we believe that the number of people willing to spend a few weeks each year on a seastead is **far** greater than the number willing to drop everything and devote their lives to it. This is even more dramatically true when you consider financial resources along with desire. In our many conversations about seasteading, we almost never encounter people who are seriously interested in living on a stead full time and have the money to buy a full share upfront. Yet we constantly meet people who find the concept intriguing and would love to try it part-time.

Earning money becomes less of a problem for the residents, because they can work normal jobs the rest of the year. Much less self-sufficiency is needed because resources flow in from the outside. As time goes on, seasteads become sea-cities, the internal economy grows, people find profitable seastead-based businesses, and more and more people can choose to live there full-time. This exemplifies our incremental approach.

Underwater Resort

While being completely underwater makes the engineering quite difficult, having some habitable underwater area has much to be said for it. It has an undeniable romantic appeal (underwater weddings? Parties? Honeymoon suites?). Jules' Undersea Lodge in Key Largo, Florida, charges \$300-\$600 per night [Jules]. It has received a lot of media attention, for example it was featured on "Lifestyles of the Rich and Famous". Hydropolis, the worlds first luxury underwater hotel, is to be built in Dubai (close to The Palms) and completed in late 2006 [ReutersDubai]. The project is funded to the tune of five hundred million dollars. Poseiden Resorts is another planned project [Poseidon]. The Global Coral Reef Alliance [GCRA] has demonstrated that electro-accretion can be used to build and sustain artificial coral reefs for diving.

Even from an above-water seasted, underwater tourism and exploration can be done via submersibles. There are some interesting personal subs on the market [Hawkes], US Submarines, as well as semi-submersibles [SubSeaSystems] suited for tourism. Remotely-operated vehicles could be used initially, as that is a lot easier than carrying around actual passengers.

Personal Resort

The Aquatic Pod Suite from the Hammacher Schlemmer catalog is described as:

The world's only aquatic pod suite that offers panoramic views simultaneously above and below the surface of the water. Circular, with a 'flying saucer'



aspect, the suite rests directly on the water, the lower portion submerged approximately five feet. Perfect as a getaway at a favorite lagoon, beach, lake or river, the suite offers spectacular 300 (deg) views of the environment. Beam lights illuminate the depths for viewing the aquatic surroundings after dark. With a 150 square-foot interior, the self-contained, circular suite has all the furnishings for two people to enjoy on-the-water living. The interior has a central air conditioning system, desalination unit, mini-bar, audio-video system with Bose stereo, king-size bed, toilet and shower. Outside, a floating terrace circumscribes the unit, providing a 6.6-foot-wide surface for sun bathing or enjoying breezes off the water. The inflatable terrace also lends stability and extra buoyancy to the suite, and protects it from scratches and bumps when visiting boats or windsurfers dock alongside. The above-water entrance is a watertight aviation design that prevents stray moisture and splashes from dampening the interior. Unlike houseboats, this unit remains permanently anchored at a specific location by an environmentally-friendly anchor that attaches with a durable, corrosion-resistant chain. It can also be towed by a boat. A 2.5kva diesel generator with exhaust silencer produces 220-volt power to supply all necessary electricity. [HammacherSchlemmer]

The listed price is \$91,100. While we don't know how well the product has sold, at least this provides some evidence of a market for floating platforms.

Retirement Home

A November 2004 article in the *Journal of the American Geriatric Society* suggested that living on a cruise ship might be an alternative to assisted living facilities. The abstract reads:

Options for elderly patients who can no longer remain independent are limited. Most choices involve assisted living facilities, 24-hour caregivers, or nursing homes. State and federal assistance for payment for individual care is limited, and seniors usually pay for most costs out of pocket. For those patients who have the means to afford assisted living centers or nursing homes, "cruise ship care" is proposed. Traveling alongside traditional tourists, groups of seniors would live



on cruise ships for extended periods of time. Cruise ships are similar to assisted living centers in the amenities provided, costs per month, and many other areas.

This article begins with an examination of the needs of seniors in assisted living facilities and then explores the feasibility of cruise ship care in answering those needs. Similarities between cruise ship travel and assisted living care, as well as the monetary costs of both options, are defined. A decision tree with selections for nonindependent care for seniors was created including cruise ship care as an alternative. Using a Markov model over 20 years, a representative cost-effectiveness analysis was performed that showed that cruises were priced similarly to assisted living centers and were more efficacious. Proposed ways that cruise ship companies could further accommodate the needs of seniors interested in this option are also suggested. Implementation for cruise ship care on the individual basis is also presented. Ultimately, it is wished to introduce a feasible and possibly more desirable option to seniors who can no longer remain independent. [JAGS_10_2004]

Seasteads have some potential advantages for a retirement home. They are affected less by the waves, which should be more comfortable, and they have more space for permanent residents. A disadvantage is that they don't go to as many exotic locations. { Other Thoughts? }

Offshore Manufacturing

There are some manufacturing processes that are sufficiently dangerous that they need fair amounts of area around them. The land acquisition costs and corresponding regulatory hoops required may be quite substantial and expensive. it's also hard to acquire a large enough buffer zone around your plant to convince people that it's safe.

For example, the oil companies have not been able to break ground on a new refinery in the US in decades { Source? - P}. They might like to have a refinery that floats. That way they can refine the crude closer to the source and just ship the finished product around. We suspect that Union Carbide feels similarly about manufacturing pesticides. Processes that do not require large energy or freshwater inputs are ideal, and for them, it may be cheaper to build a seastead than go through the permitting process on land. it's also a lot faster. This is true even for a clean, non-polluting plant.

What is nice about this example is that it provides a truly gargantuan market, worth literally billions of dollars, if seasteads provide a useful solution. Investors like to see a large

potential upside. It may be possible to get some capital from relevant industries, as the cost of seasteading research is small compared to how much it might save them.

One interesting twist is an industry which requires little in the way of physical raw materials: outsourced coding. A business trying to do this was founded in 2004:

Take a used cruise ship, plant it in international waters three miles off the coast of El Segundo, near Los Angeles, people it with 600 of the brightest software engineers they can find around the world (both men and women), and run a 24-hour-a-day programming shop, thereby avoiding H-1B visa hassles while still exploiting offshore labor cost arbitrage and completing development projects in half the time they'd take onshore or offshore...

The scheme first came to Mr. Cook one day while he was cutting his grass in San Diego. With his unusual background as a super-tanker captain and an IT professional, the idea made a lot of sense to him. He took it to Mr. Green, with whom he'd worked before and who has served as both a buyer and provider of outsourcing services, and they saw the possibility of creating a new form of IT sourcing.

A year ago, they formed SeaCode, Inc. with Mr. Cook serving as CEO and Mr. Green as COO. They've signed on a marketing director and CTO and, even more importantly, found an investor. Start-up costs won't be cheap. A broker right now is searching for just the right ship to buy - somewhere in the neighborhood of \$10 million. [SourcingMag2005]

Ocean Science Platform

In order to study the ocean, ocean scientists normally need to get on a boat and go out to sea. It would be useful to have a platform that stays on station from which they could do their research. Under this scenario, the seastead would be towed to an interesting location and the research would take place as a dedicated community. The benefit of having the scientists always on station may outweigh the additional costs of operating a seastead. An example of such a platform is the Scripps Institution of Oceanography's Flip, or Floating Instrument Platform, which can float horizontally or vertically.

Environmental Demonstrator

The kinds of seasteads described in this paper will be quite self-sufficient once they are built. As such they will appeal to members of the environmental movement as an example of how to build communities that live within their environmental means as opposed to the resource wasteful communities of today. In addition, the environmentalists have successfully managed to raise large amounts of money to support their cause. Perhaps several of these organizations could get together to fund an environmental demonstrator seastead.

World Library

Most of the countries in the world have signed onto the Berne Copyright Convention. A seastead in the middle of the ocean is not bound by any copyright laws. Thus, it would be legal to obtain and digitize a vast library of material that national and university libraries can not amass simply because of copyright restrictions. While it would not be possible to export this material back out to the Internet, one could imagine researchers choosing to come to the world library seastead simply because they could do their research in a fraction of the time required to do it using conventional libraries.

Patent Free Zone

Patent laws vary from country to country. There is a push to unify these various patent laws across all of the industrialized nations. A seastead in the middle of the ocean would be exempt from all patents. Thus, to save money, somebody could choose to implement some portion of a patented process on a seastead. While nations could choose to impose tariff on products imported from a seastead, not all countries would do so.

A risk with such a venture is that a corporation who is being infringed upon might encourage their friendly national navy to board the seastead and shut it down. As will frequently be the case, the seastead must balance the profit and attractiveness of unique approaches with the potential problems.

Marina

Marinas offer services such as shelter, water, food, electricity, and medical facilities to the boating population. While seasteads may not be able to supply the same level or price as land-based facilities, they can service remote areas where other options are not available, as well as offering some unique attractions. The seastead can be moved whenever the current crop of boaters in a given area grow bored, thereby picking up another crop.

Tour Base

A seastead could serve as the base for touring some unique and remote area. It would offer more roomy and luxurious accommodations than a boat, and provide a runway, allowing for access by air instead of sea. The tour destination could be an island or archipelago, something underwater (reefs, sunken ships), glaciers, or anything else remote and interesting. If the seastead is mobile, it may periodically move so that it can offer an endless variety of tour destinations.

Fishing Base

A seastead could serve as a supply cache, storage facility, and processing facility for commercial fishing, allowing fleets to go farther and stay longer.

Mariculture Products

There are a number of products which seasteads could manufacture and sell to the rest of the world. In *The Millennial Project*, Marshall Savage discusses several options, including protein powder from spirulina algae, pearls, seaweed, fish, and shellfish [Savage1992 pp. 44-57]. Seaweed can be made into paper and textiles.

Seasteads may have a major advantage for mariculture, if they create upwellings. Once OTEC is a viable energy source, or perhaps earlier if wave-powered pumps such as the Isaac's Pump are used, seasteads will be bringing nutrient-dense water to the surface as a side effect of generating power. This can be used as the base for a food chain of aquatic life. { expand this discussion? Need references }

Advanced Medical Research and Treatment

Government bureaucracy is a major barrier to medical and biotechnological advancement. The FDA has historically been slow to approve new medical treatments, and promising areas such as stem cell research have been curtailed by governments. Seasteads would be an excellent place for cutting-edge medical research and treatment.

Communication Station

Ships far from land generally communicate via satellites, which are very expensive and have a high lag time. Seasteads could extend this range, providing phone/internet service. The platform would be connected either to an undersea cable, or by bouncing through some relaying platforms. The seastead design's height and stability make it well-suited to being a communication tower.

Virtual Services

This category includes banking and financial services, corporation registration, and internet hosting. Some readers may be surprised to see this category listed so far down, as these have been often proposed as natural businesses for a new nation. Unfortunately, we see them as problematic. While there is a large market for virtual services, there is also a lot of competition. Any country with a fiber optic connection can enter these industries, and many have. The simplest way to look at it is that the required infrastructure (commu-

nications bandwidth) is much, much cheaper on land than at sea. Thus it is unlikely to be a comparative advantage for a floating city.

For example, we believe that one of the reasons HavenCo had difficulty finding customers was that they had to compete with the Bahamas, Panama, Costa Rica, etc., with little extra to offer. Their regulatory advantages were offset by bandwidth and cost disadvantages. Virtual businesses can always switch jurisdictions if there is a crackdown, or locate redundantly in multiple countries. There are better ways (like cryptography) to achieve the desired goals of a data haven than putting it in a remote location.

Financial service industries are quite conservative, and it will be a long time before seasteads are seen as stable enough. Additionally, since these services can be located anywhere, seasteads must compete against the top jurisdictions in the world. And that is a difficult task.

Energy Production

This business model is not exactly far-fetched, given that it's what the vast majority of fixed ocean structures have been built for. Besides oil, there is methane hydrate, as well as a wealth of renewable power from the sun, wind, and waves. While such sources are currently not competitive, it is certainly possible they will be in the future. The ocean is a great place to get wind energy, since speed is higher, and energy goes up with the cube of speed. With a large enough budget, OTEC may be feasible. With the right system, wave power could be economical. Nuclear power could be kept offshore to reduce the negative effects of a meltdown (although such problems are very unlikely nowadays). Any of these sources could be used to make hydrogen, which would be shipped away.

As with any seastead business, there will have to be good economic reasons to generate energy on the ocean, since maintenance is more expensive. Since there are substantial transmission losses, it's best to generate electricity close to where it is used. However, as we can see from oil platforms, OTEC, etc., some aspects of this industry actually are suited to being done at sea.

Space Launch

{_Todo: add this picture: <http://upload.wikimedia.org/wikipedia/commons/b/bf/SeaLaunch-Odyssey.jpg>}

There are a number of advantages to launching from the ocean, particularly over the equator. There is one existing company called Sea Launch which uses a semisubmersible called the Ocean Odyssey. They have launched 29 rockets as of September 2008, with 2 failures and 1 partial failure, according to wikipedia, with all payloads being communication satellites. The cost of the project was about \$600M. Here are some of the advantages listed by Wikipedia:

- The rotational speed of the Earth is greatest at the equator, providing a minor extra launch "boost".
- The need for a "plane change" to the zero degree inclination of geostationary orbit is eliminated, providing a major extra launch "boost". The same rocket launched from Cape Canaveral at 28.5 degrees north latitude would lift 15%-20% less mass to geostationary orbit.
- An ocean launch reduces risks related to launching over populated areas, providing better safety to third parties.
- Absence of range conflicts with other launch systems and a near total absence of ship or overhead air traffic that would constrain launch.

- Any orbital inclination could be reached, thus (for example) combining in one launch site the attainable inclinations of both Cape Canaveral and Vandenberg.

To this we add:

- It makes recovery of booster stages easier, since the ocean is softer than land, and it's easier to get anywhere on it, and transport something heavy back.
 - Heavy regulation in countries like the US slows innovation in the space industry, partly because of these safety risks, and the ocean would be a lower regulation environment.

Cargo Transshipment Port

Many people know about the incredible wealth of Hong Kong, an area with few natural resources. Some of them know about the free market policies which helped lead to the wealth. But Hong Kong's placement is also crucial - it is in a convenient location to act as the cargo gateway from Asia to the world.

There are some locations that are naturally suited to transshipment, ie moving cargo between ships. Since a seastead can go anywhere, we can just look at the entire ocean, find the point in the water that would be a bustling port if only there were an island there, and build one.

Aquaculture

If you're not familiar with the term, aquaculture means raising sea creatures like finfish and shellfish. The parallel goes something like:

Hunting Ranching

Gathering Farming

Fishing Aquaculture

Agricultural Revolution ? Aquaculture Revolution ?

If you look at the transition from hunter/gatherer to modern agriculture, you see a huge gain in efficiency which allowed human population to skyrocket. Current ocean fishing techniques are much like hunting. There is a classic tragedy of the commons problem. Each individual gains from depleting the oceans, and no one replenishes them because others would get most of the benefit. Since no one owns them, technology goes into better harvesting and processing, not better production.

The standard way to solve such a problem is to privatize the commons. While some novel schemes for creating property rights in fish have been used in coast areas, it's much harder with migratory ocean fish. But aquaculture solves tis problem, since it generally involves raising fish in huge nets. It seems likely that this will produce a drastically higher output per unit effort, just as happened with food production on land millenia ago.

Not only can we get a cheaper supply of marine products, but there is a huge demand for aquaculture. Not only is the world's population increasing, but people are eating more fish as the health benefits become more widely recognized. There is no other way to meet this demand, besides offshore aquaculture. Production by fishing is expected to remain flat at best, due to the overfishing problems mentioned. Freshwater aquaculture has to compete with all the other demands for freshwater by our growing population. Most seawater aquaculture occurs in coastal regions, which are also in high demand. So offshore is the only way to go, and thus this is a very promising business opportunity for seasteads.

As you can see, there are quite a variety of business possibilities for a seastead. We believe there are many potential customers as well.

40.1 Market

{Wayne - There is a market. ResidenSea, Club Med, general interest}
 { Not clear that this should be a separate section. ie Market depends on Business Model.
 Should merge. }

Libertarians

Historically, many new-country projects have been envisioned by freedom-oriented individuals. Such individuals have contributed time and money to projects much less realistic than seasteading. Thus we think it is reasonable to expect a great deal of interest in our project from the libertarian community once it is clear that our plan is actually feasible. While US National Libertarian Party membership has been steadily declining, we believe that this is a result of libertarians becoming weary of the lack of results, not a philosophical change in the population. The so-called "War On Terror" is currently adding more bite to the Libs perennial dissatisfaction.

Environmentalists

The past few decades have seen a huge trend towards increased environmental awareness. The Sierra Club had over 600,000 members in 1996 [Sierra1997]. The Nature Conservancy is the nations tenth largest nonprofit, with assets in 2001 of almost three billion dollars, and annual contributions of over five hundred million [NatureCon2001]. Contrast this with 28,000 members of the US National Libertarian Party (as of 11/2001), and you see that environmentalists may be the largest market. Self-sufficient seasteads with their low environmental footprint will have tremendous appeal to these individuals.

Recreational Drug Users

Recreational drugs are illegal almost everywhere in the world. While they are still widely available, prices are high, quality is erratic, selection is poor, and users risk imprisonment and the confiscation of their possessions. The fact that such a market exists despite these factors is indication of the vast demand for these products. We believe that there is a substantial market for a facility which offers a wide variety of high-quality drugs in a legal setting with available medical care in case of emergency. Even after the extra costs for "doing things right", such as medical facilities and rigorous purity testing, the profit margin for recreational drugs is immense.

One particularly interesting part of this market is for those individuals interested in receiving psychological therapy which uses psychedelic drugs as part of the counseling. For example, MDMA (ecstasy) was widely used for this purpose while it was legal. The Multidisciplinary Association for Psychedelic Studies (MAPS) has received FDA approval for a \$5M, 5-year clinical study to evaluate MDMA for the treatment of post-traumatic stress disorder [Doblin2002]. Anecdotal reports of the success of MDMA-based psychotherapy for individuals unable to progress through conventional methods are extremely positive [Shulgin1991 pp. 69-75, Shulgin1997, Stafford1992 pp 78-80]. Several other psychedelic drugs have shown great promise in studies as well, such as LSD [Stafford1992, pp. 78-82].

One positive aspect of this kind of drug use is the resulting publicity. While using drugs recreationally has a negative association, medical use is seen in a positive light. Medical marijuana treatment is a good example, and as some conditions require chronic use, it is more likely that sufferers will find it worthwhile to move because of their condition. At least two individuals (Steve Kubby and Renee Boje) have sought political refuge in Canada because the US would not allow them access to medical marijuana.

Note that the extreme paranoia of the US about drugs may restrict the possible locations for seasteads catering to this market. For example, the Caribbean might be close enough to make Uncle Sam uncomfortable.

Deep-sea Sport Fishermen

These people are just as fanatic about their hobby as anybody. They will spend serious amounts of money to bag a tuna or the like. They might like the option of being able to camp out on a seastead at night rather than always having to return to shore or camp out in the crowded ship. This requires that the seastead be parked where deep sea fishing occurs.

Scuba Divers

Scuba divers are another hobbyist group that loves to spend money. If the seastead is parked near some interesting reefs, it becomes a reasonable place for them to visit.

Boaters

People who own and operate boats (sail or motor-powered) often have extra money on their hands. They might like the challenge of locating and visiting a seastead. If there are interesting facilities on board, so much the better.

Aviators

People with personal helicopters and STOL aircraft might like the challenge of landing at a seastead.

Commercial Fishermen

Seasteads could provide supplies, storage, and general support for commercial fishing, as well as emergency medical facilities.

Some combination of these approaches will likely be used. For example, a residential seastead (condo, time-share, or hotel) might devote part of its area to research experiments. Since it would have a dock and infrastructure, it might as well sell its amenities to boaters. Residents would have access to a digital library, as well as deep-sea fishing and scuba diving equipment. Fishing, diving, and interesting tours would help fill hotel rooms. As time goes on, the market will determine which seastead services have the greatest demand.

One may well ask how a seastead can compete against a world full of other recreation options. There are many resorts, each competing to lure travelers - isn't the competition tough? Won't the primitive amenities be a major downside? It is clear, however, that there is a demand for resorts with primitive amenities, since many exist. We can't initially offer tennis courts and the comforts of home, but even if that rules out 99% of vacationers, that's OK. All we need to do is appeal sufficiently to a minority that they prefer us over other options. We think that the novelty of a seastead as a work of engineering, an environmentally sustainable community, and an experiment in self-governance will get us that minority.

40.2 Cruise Ship Condos

There has been a long and active debate about the relative merits of different structures for seasteading, such as spar platforms, breakwaters, SFS (ranging from SWATH to spars to Water Walkers), sailing ships, or retrofitted cruise ships. Seasteading is by its nature a diverse movement - of business models, governmental forms, and structure designs, as in Wayne's Venice Concept

Our initial research focused on the spar platform as the most promising structure. Now that development of our patented ClubStead design is wrapping up, we are going to evaluate some of the other contenders. Breakwaters were extensively discussed in this Weekly Research topic, and we are considering how best to explore single-family seasteads. We are also going to investigate retrofitted cruise ships - starting with this blog post.

My previous opinion on ships is best summarized by the FAQ for "Why not just buy a boat?", which concluded: *"Weighing these factors, we think a platform is a better approach if your goal is to create permanent ocean settlements. However, boatsteading is a pretty*

reasonable strategy as well. It may even be better in the short-term, but we think it is much less likely to transform the world."

It is part of our strategy to research and attempt to nourish both the residential and commercial sectors. Discussions with investors and entrepreneurs have indicated that seasteading-related businesses such as medical tourism need to be proven at a smaller scale than ClubStead (which costs ~\$100M) in order for a spar platform business to have a chance to be funded. So ships seem a natural stepping stone along the path to larger commercial seasteads. And in the same way, ships seem a natural stepping stone along the path to larger residential seasteads. And in terms of business models, just as near-shore medical tourism is a small extension of medical tourism to distant countries, given that short-term travel on the ocean is a proven industry (cruise ships), it seems natural to extend it to long-term residency.

Additionally, some new information has come in since Wayne & I wrote our recommendations for spar platforms in the book alpha version 5+ years ago:

- Cost - Ships now appear relatively more cost-effective than we'd thought, for several reasons:
 - Used ship prices have plunged with the global recession and shipping slowdown - the Baltic Dry Index reached a 22-year low in December of 2008.
 - The industry is in a slowdown, and consolidating its fleets to larger vessels, so many smaller used cruise ships (~700 pax) are for sale right now.
 - The cost of ClubStead seems to be a bit higher than we had expected ($\$400+/\text{ft}^2$), based on preliminary estimates.
- Legal Status: Our legal research recently determined that while a ship is under the flag jurisdiction beyond 12nm, artificial platforms are regulated by the coastal state throughout the EEZ (200nm or more). Initial ventures will probably want to be near-shore, testing and proving seasteading at 12nm before we are ready to go to 200nm.

Cost and legal status are two of the most important criteria for a structure, so this argues in favor of ships as the first incremental step for the residential sector. I've been mulling over how retrofitted cruise ships could be made to work as a near-term business for the last month or so, and am ready to present an analysis for feedback.

Business Model

The obvious business model is a cruise ship condo, like ResidenSea but priced for the middle-class. Size would depend on the level of interest, but I'm thinking something like a 700-pax ship, leaving small rooms for 200 (guests/staff/frugal) and converting 500 pax of rooms to condos for 100. The combination of permanent residents and timesharers/vacationers would travel the world on a retrofitted cruise ship, with an itinerary timed to catch major world events like the Cannes Film Festival, Carnival in Rio, Burning Man, and Olympics. The vacationers would be funded by dirtside jobs, while the residents would be a combination of retirees and telecommuters.

Initially, signups would be taken as a contingent contract, where people would sign: *"If a residential seastead can be built for $< \$200/\text{ft}^2$, and 200 people (permanent residents and prorated timesharers) sign up, I will purchase at least $AAA \text{ ft}^2$ for $BB \text{ weeks/year}$ "* filling in their values for AAA and BB (52 for full-time).

Pros and Cons by Area
Structural (Ship-shape)

- (+) Proven over centuries. Minimum engineering novelty.
- (-) Doesn't seem/feel new/different. This means it less PR, less feeling of pioneering, perhaps less attractiveness to customers.
- (-) Poor stability when stopped in deep ocean (turns beam and then rolls). Must spend time either traveling or in port.
- (-) Optimized for movement. Space and solar footprint are limited.

Location (Mobile) * (+) Mobility is nice to grow a social movement - ship can give talks / host socials all over the world as it travels. * (+) Shopping / resupply is easy due to frequent port visits. * (+) Less likely to have political problems if only in/near each country for a little while. Can skip countries that are problematic. * (+) Thanks to cruise industry, there are great dock facilities in many ports for cruise ships, often with good access to shopping and dining areas. * (+/-) Mixed in attracting people. People like cruises to visit many places for vacation. But they also tend to like to stay in one place and build a network of friends for permanent living. * (-) World travel limits onboard businesses / occupations - medical tourism is tough w/ no fixed location, for example. Phone/internet-based businesses may be all that works. * (-) Being in domestic waters so frequently may pose significant legal challenges (varying laws for things like drugs & guns). Perhaps the ship can lock them up when in port? Might even have to leave a "pod" (ocean cache) outside territorial waters. Messy logistics there.

Legal (Ship flying a flag) * (+) Ships have one of the best legal statuses. Outside 12nm, the flagging state has jurisdiction, and flags of convenience for ships are standard. Whereas platforms are regulated by coastal state within 200nm EEZ. Also, we get to use the "legal shadow" of the cruise line industry (precedents set by their political power). Ship is less likely to have a path to sovereignty, but we should be building breakwater cities long before sovereignty is an issue.

(Note that this venture would be a separate legal entity from TSI)

Financial (Residents: condos / timeshares)

- (+) Ships are particularly cheap now due to recession and shipping volume decline (Baltic Dry Index).
- (+) As a proven, mass-produced technology, ships are relatively inexpensive. Purchase and retrofit may even be able to be financed by loans.
- (+) Condos / timeshares gives a clear funding model for both residents and guests.
- (-) Somewhat competing with the existing cruise industry, which has much more experience and economies of scale. Vacationers onboard are directly competing w/ cruise lines. And more may enter the market if we prove the model.
- (-) ResidenSea was a failure financially.

Timescale * (+) Can be done now with no new engineering. Once the venture has customers and funds, it should be able to buy and retrofit a ship in 1-2 years.

Modularity/Scaling * (-) Not very modular - can't expand incrementally. There is the possibility to expand by trading up to a larger vessel, or by adding ships, but this is not seastead-style expansion building a city one block at a time.

Unknowns

Some of the information that seems important to me in evaluating this strategy:

- Does this approach (business model and structure) appeal to our community? It will only work if there are customers, so this is important.
- How much does it cost? (price ships & retrofitting). What about relative to Club-Stead? What are the prospects for additional cost savings from improving the Club-Stead design?
- How many people are needed for a breakwater city to be cost-effective? The smaller the number, the less we should worry about non-seastead aspects of short-term strategies like ships. The larger the number, the more we want modularity in our pre-breakwater structures.

Conclusion

The cruise ship condo approach is a promising near-term strategy which bears further investigation. The tradeoffs are complicated, but at the core it comes down to a question of novelty and how big our first steps should be toward the long-term goal of seastead cities. The ship route is cheaper, easier, has a clearer place in the existing business and legal landscapes, and can be done sooner. But its lack of novelty means it is less interesting and exciting to potential seasteaders and the media, and more poorly suited to our long-term goals.

We must weigh the advantages of an easier start against the dangers of losing our unique vision. You are part of "We", so your feedback here is welcomed.

As of May, 2009, TSI is actively developing a business plan for a residential cruise ship.

Chapter 41

Open Source World Library

A scene at Ephemerisle "Aha", John said, as he sees the pirate flag with an image made from 1's and 0's. "This is what I was telling you about!". "A place where you can copy some guy's music? What's the big deal", replied Richard. "Oh, it's a lot more than that. Just watch." John approached the desk, where cat-10 cabling lay everywhere, connecting ethernet hubs blinking crazily to a home-built rack of servers. "It's a linux-based redundant filesystem, based on Google's GFS. Like RAID, but managed in software. Each bit is replicated several times so any one hard drive can fail. The rack has 100 terabytes of storage - and I bet they'll need more soon." He sat down, took out his laptop, and plugged it in. "First I run the client program, and point it at my media folders - music, movies, and that sheet music I've been collecting from school. It hashes every file, finds out what it doesn't have, and copies it. Meanwhile, we browse what it has..." "Woah", said Richard, as the menu popped up. "Music, movies, books, academic papers, sheet music, code, DNA, fizzobs... that's a lot of categories! And what are fizzobs?" "Physical Objects - 3d models of useful things like, well, the parts to make a 3d object printer!" "Are they pirated, though? Isn't a lot of that stuff available online?" "Definitely", replied John. "But the idea isn't just to have things protected by copyright - it's to collect all the useful knowledge of the human race, whether or not people want

The idea here is to develop a world library of digital media, managed by open-source software. Typical forms of interaction would be:

- *Contributing.* You bring your laptop or a portable hard drive, and hook it up to the network, where there is a large distributed filesystem. You run an app and point it at your media directories. It copies anything you have that it doesn't.
- *Copying.* It gives you a browseable / searchable interface to find and copy from the library. This needs to be done with nice tools. One way would be to piggyback on an existing system - for example, if you know the ISBN for a book, you can annotate Amazon.com pages with links to the library. Similarly with movies and IMDB pages. So the IMDB is your database and searching system.
- *Cleanup.* The tricky parts are in metadata and data quality. Metadata, so you can find the information you are looking for. And to avoid duplicates - so you don't get 25 versions of the same song / movie. Hashing the contents prevents you from exact duplicates, but since music and movies can be encoded in many different ways, you may still get "soft duplicates". There are algorithmic techniques for identifying these, but they are imperfect. In the import stage, the library might reject MP3s that aren't well ID3-tagged, just because there is going to be so much data it can afford to reject contributions with poor metadata. It might also require users to do some data cleanup in return for copying from the library - say, identify an untagged movie.

We're envisioning this as an open-source project, which has a lot of advantages. There isn't any single world library - not at the beginning. Anyone can use this software to set up their own collection - whether at a LAN party, or at a conference or festival. People all over the world would contribute to the code, so that functionality increases over time. Given many different Libraries, one usual function would be to diff two Libraries, and put anything the first has that the second wants onto a hard drive, to be moved by sneakernet (ie physical carrying). This lets Libraries sync up without information going over the network. If the Libraries have fast enough network connections, they could also sync over an encrypted connection.

As in our story, this has the potential to extend well beyond the obvious areas like music and movies. We are moving more and more into a world of information - where 3d printers can make any object, if they know it's shape. Where biotech hardware can create gene sequences. Where both of these things - gene sequences and object models - are currently being patented, and reserved for the use of their discoverers. The incredible potential of this technology to bring on a world of plenty, a world where you print a new part when one breaks, instead of sending to the factory, is threatened by these government-granted monopolies on information.

Exploring this fascinating topic in detail is outside the scope of this book, but suffice it to say that the only way to stop the World Library is the establishment of a draconian world government that would be far worse than letting information be free. We're going to build seasteads to help make sure that global fascism scenario doesn't happen, and so the World Library is an inevitable consequence. It's time to think about how to use it, and how to encourage content creation in this new regime, rather than continuing to fight the inevitable erosion of copyright.

Part VIII

Making it Happen

This next section contains our opinions about the current state of affairs with regards to making seasteading happen.

You can view these as a selection of business models (from Making Money), funding strategies, and choices along the Incrementalism axes discussed initially.

Chapter 42

Low Road vs. High Road

A frequent distinction which comes up when discussing seasteading strategies is between the so-called low-road and high-road approaches. While this is not a perfect distinction and many proposals fall in-between, it seems to be a pretty fundamental axis along which people's worldviews fall, and so it may be a valuable classification. However, it is worth noting that some people really don't like the distinction and don't find it useful - when a draft of this section was [posted to the TSI blog](seasteading.org/stay-in-touch/blog/3/2009/05/21/some-take-low-road-some-take-high-road#comments) it generated a fair bit of controversy.

While there are no standardized definitions, I'll present my view of the two paths. Note that I am presenting two extremes of an axis. Most ideas have some elements of each, and I am not saying that every low road project must have all the low road characteristics. Yet there is enough correlation between these elements that I think these categories are meaningful.

Low Road: DIY Seasteading

The low road is small-scale, low-capital, high-labor DIY seasteading. It tends towards self-sufficiency and disconnect from the global economy. It will likely be funded, built, and run by the occupants.

Some low-road approaches are:

- Go to the doldrums (where there are minimal waves), build some cheap platforms, and use self-sufficiency technology to minimize the need for trade with the outside world. This approach has been proposed on the nation-builders mailing list on Yahoo groups.
- Build a DIY single-family seastead which is largely self-sufficient and sail it around the world, always having nice weather. Vince Cate has written an excellent manifesto on the advantages of this approach (?include in appendix?). Vince has some specific design ideas: Water Walker and Tension Circle House. Note that Vince's vision is not necessarily DIY, and is not meant to be self-sufficient, which differentiates it from the pure low-road approach. (In a good direction, in my opinion, since self-sufficiency is what I like the least about the low-road).

Pastor Jason's Belize Basestead Proposal is a more detailed explanation of a low-road approach:

Seastead Outpost: Belize is still in the early stages of planning. Much of what I am going to share with you is subject to change, however it should give you a view similar to my own of how this effort is taking shape. Critique and advice is welcome, explain how to do something better/different and we'll incorporate it if it works.

The property will be purchased by an individual(me) or small group of people. The property needs plenty of space (as this operation will need to expand and grow over time), and access to the sea (for our seasteading efforts of course). Those who wish to be a part of this, without the ability to invest any capital themselves, will be invited to live and work in exchange for living quarters, food, and the materials needed to experiment with seasteading technology. Though an initial compact will be signed and agreed upon for a certain amount of time (1-2 years?), anyone is free to leave at any time... but you leave with what you came with, can't take anything with you.

The first group will be roughing it for a while as no buildings or infrastructure is in place at this location. We'll focus on building these structures and infrastructure. Self-sufficiency is the name of the game... MDI concrete dome buildings, PV solar power, rainwater collectors, etc. It takes a certain type of person for this first phase and I am that type of person. Seems I'm not the only one, at least half (if not more) of those seriously interested in this project want in during this period. Our group will work as an intentional community, working together, eating together, sharing sparse quarters together.

With a basic settlement with infrastructure set up, we'll begin to shift our focus over to developing seastead technologies. Those of us with families will have them come down to join us (in a much more comfortable lifestyle than the first couple of months). Micro-farming, aquaculture, seastead models, algaeculture, waste recycling/disposal, water desalination, etc. TSI has already agreed to aim monies for R&D efforts in our direction as a form of support. We'll continue to build, as we'll need workshops, storage, fabrication facilities, as well as additional housing areas that will allow folks from TSI to visit and participate for a limited period of time. It is this area that some see an opportunity for eco-tourism as a source of income. Our group will continue to act as a communal society at this point, though we'll have our own quarters with shared common areas and each individual will work for the benefit of the community as a whole. At this phase, we'll experiment with unique economic models to see how things could work on a small scale.

After a year or two (whatever the initial agreement is between the property owner and those who come) the agreement will be done. Seastead Outpost: Belize will be a developed property that suits the needs of wanna-be seasteaders and eco-fanatics everywhere. We'll have a completely self-sufficient micro-society with the ability to generate our own power, clean water, and abundant food. It is our sincere hope that a fully functional seastead would be floating near-by awaiting her first crew to take her out into the deep blue. Those who wish to stay behind will still be a part of seasteading as our outpost will act as a crucial connection for the seastead to the rest of society. Those who stay will likely be running one of the industries they worked so hard to create and work at over the past few years. A simple economic system (that does not rely on outside currency) will empower each individual to make their work as efficient and profitable as they like. This economic system will extend to the seastead as

they will likely need some help from the outpost until they can get self-sufficient themselves... and even then, we'll each be better at different things so trade will make sense.

Anyone who wants to get rich in the currencies of current countries would probably do better for themselves to stay put. Those who want to be a part of something new and give their progeny a fresh start in a truly free atmosphere may judge this plan to offer great amounts of wealth. I'm somewhere in the middle myself. I can say this for certain: Anyone who does come along, at any point, to Seastead Outpost: Belize will be fundamentally changed by the experience.

Note the focus on self-sufficiency, new economic models, building things with your hands, etc.

The advantages of the low road include:

- You don't have to be rich, or know anyone who is.
- The primal satisfaction of working with your hands.
- Self-sufficiency is freedom.
- Start now.
- Specific advantages of single-family dwellings:
 - Each family can travel where they want to, and controlling where you travel is freedom.
 - No need for new social structures as family is well understood unit
 - Mass production of many small seasteads gives economies of scale

A major disadvantage is that self-sufficiency technology is essentially an abandonment of the modern global economy with its gains from trade, specialization, and scale. Proponents see this as an advantage either because they think it is necessary for freedom, or because they see the modern economy as broken and want to fix it. I, however, am quite fond of the modern economy and its wealth and see self-sufficiency as an enormous step backwards. You can make up your own mind.

One can perhaps characterize Sealand as a somewhat successful low-road project, but in general, low-road projects seem to be just as stuck in dreamland as high-road ones. Despite proponent's claims that this approach is vastly easier and more practical, it's still all talk no action (just like the high road).

High Road: Seasteading For Profit

This strategy, by contrast is large-scale, high-capital, and integrated into the global economy. It relies on specialization and trade. Most residents will not directly create what they consume, but rather, will work at a specialized job for money, and then use the money to buy what they need. It may be funded by occupants or investors, will likely be built by specialists and operated by professional property managers.

Some high road approaches are:

- Operate a medical tourism or condo cruise ship.
- Build a hotel / resort on a spar platform, like ClubStead.

The advantages of the high road include:

- You can do specialized, high-paying work.
- Things you use are provided by specialists with a comparative advantage: your seasteeds are built by shipyards, your food is grown on land.
- More luxury, higher level of comfort (easier to convince the wife!).
- Tends to get more publicity, hence easier to grow a movement. (Although this can be a double-edged sword, as the publicity can distract an organization from more important work).

The peril of the high road is that it can easily lead to nothing but castles in the air - a website with 3d models and no physical implementation, business plan, legal entity, etc. Actually doing a high road project requires business acumen, investors, customers, and the ability to successfully manage a large project. So far, nothing has resulted from this strategy.

Compare & Contrast

The development of the modern world can be viewed as a movement over time from the low-road to the high-road model. Modern wealth comes from the fact that we have specialization and economies of scale, rather than having each group of people grow its own food, make its own tools, and so forth. However, with wealth has grown government and regulation. Economic interdependence has led to political interdependence. In other words, self-sufficiency means both poverty and freedom. The high-road accepts entanglements to get wealth, while the low-road accepts poverty to get freedom. Neither is ideal, and each is the natural result of different preferences and priorities. Rather than arguing for one vs. the other, I will instead talk about some of the characteristics and attitudes that tend to lead a person to favor one over the other:

Low Road: The Pioneer Job skills Hands-on, self-sufficiency Knowledge worker Capital Low High Income Low High Lifestyle Focus Minimize costs- Maximize income Do It Now - yourself! Right - hire a specialist! Individualism Prefers freedom of small group / own building Prefers diversity, economies of scale of larger group

The difference between current low road and high road lifestyles can be seen by contrasting live-aboard boaters and the cruise industry.

Live Aboard Boaters Go where you want, when you want Go where the customers want, when they want Costs money Makes money Funded by owner Funded by investors Need sailing and self-sufficiency skills Need skills for the jobs on a cruise ship It's cramped and uncivilized! Who wants to live there? It's a vacation or job, not a life Passion- Profession Small and lonely Community - but temporary Hard to control: small, anonymous- Large, capital-intensive means easier to control

These differences result in conversations like:

Pioneer: Single-Family Seasteeds are the way to go! Anyone can build one and live on it and be self-sufficient. Entrepreneur: Uh...if they know how to build things. And know how to grow their own food. And don't mind living in a confined space with a few people and no satellite internet.

Entrepreneur: Cruise Ship Condos are the way to go! Anyone can go live on one. Pioneer: Uh...if they have a couple hundred thousand dollars to buy a condo. And a job that can pay for food and fuel and is portable all over the world. And don't mind having to compromise on an itinerary with 200 other people.

Some actual quotes:

DanB: "Vince really wants to live on a single family 'stead, but to me the prospect is completely unappealing, partially because I don't have a family. Jason really wants to do the DIY thing and grow his own food; to me that sounds unappealing, because I don't know how to farm."

Chapter 43

Ways That Don't Work

There is a common element which shows up over and over in the new-country projects which have failed (almost all of them). It is unrealism, such as denial of current international policies, dependence on a nonexistent technology, and so forth. Some typical examples are:

Antarctic Homesteading: A 60-page single-spaced typescript prospectus for this project was forwarded by the editor of *Free Country Newsletter*...The basic concept is for people to go to Antarctica and settle. A scenario is laid out to start unfolding in 1981, beginning at a Southern California conference, with growth from 1,000 people to 4,000,000 by 1985, but there is no indication that anything was ever done. The financial base was to be concerts by John Lennon (no indicating that he was ever contacted), films in the Jacques Cousteau genre of Antarctic sunrise and sunset, and international conferences on religion and war and liberty...This is a typical example of new-country projects that are mainly used as vehicles for the organizers' daydreams (a practice by no means limited to the political left, as others of these case histories shows), with little regard for the harsher realities of the world - such as the fact that the great powers are unlikely to permit claims to Antarctic territory to become established facts (just recently, the British forcibly removed an Argentine weather station in the Antarctic). [Strauss1984, p. 54-55]

Oceana: The idea germinated in 1969, among an American college group oriented to the Objectivist writings of Ayn Rand...This can be viewed as an illustration of the problem of attracting too many chiefs, and not enough Indians. Because Oceana was essentially a zero-dollar operation, and thus couldn't offer immediate material incentives, it fell naturally (though inadvertently) into the trap of gaining recruits by (implicitly) offering them a full voice in the running of the venture. Thus a high proportion of people were attracted whose main interest was in endless fantasizing and dickered over details. When the time came for a commitment to be made...the idle bull-session types took their leave. [Strauss1984, p. 111-112]

These stories are common, and while we hope that the organizers enjoyed their daydreams, we seek a more tangible payoff.

The most common form of unrealism is probably scale, visions which are huge and expensive. Given enough money and will it is possible to build just about any kind of structure in the middle of the ocean that you can think about. Unfortunately, the tough part is coming

up with enough capital to make it happen. Let us examine the state of a few relevant projects which attracted a fair amount of interest.

There has been very little visible progress with the Atlantis project for quite a while. Their webpage states that the project is defunct.

The Aquarius portion of the New Millennium project seems to have gone through a number of phases:

Phase 1 (Enthusiasm): Initial enthusiasm and excitement Phase 2 (Replan): Several replans to reduce project costs Phase 3 (Bummer): The growing realization that even the rescaled plans are still too expensive Phase 4 (Slow Death): Growing disenchantment with the whole project and a slow exodus of people working on the project. (This last part is still a bit speculative.)

Similarly, New Utopia seems to have gone through some phases of initial enthusiasm, planning, and then the realization that it wasn't going to happen. The realists then left, leaving the project in the hands of those unable or unwilling to acknowledge the facts. Ian Sawyer's comments are a good indication of this:

I was involved with the project as one of the Board of Governors from early 1998 through to late 1999, resigning after very major problems started appearing in the whole basis of the legality of New Utopia and Prince Lazarus' dogmatic and dictatorial approach to them. Unfortunately I am restricted somewhat on what I can say as the result of a court ruling following a spectacularly unsuccessful attempt by Lazarus to sue me and a colleague for \$10 billion, however there are copies of all the correspondence, which include the legal basis for the reasons I resigned from the project and all the subsequent comments by Lazarus and others, on the New Utopia Discussions Group with Yahoo at <http://groups.yahoo.com/group/new-utopia>, starting in October 1999. There have been further exchanges on the present position of New Utopia as late as the end of 2000 when it seems to have regrettably become little more than a scam.

Other nation founding groups seem to have similar lifecycles, where an initial burst of enthusiasm gives way to a growing realization that it will be impossible, or at least a huge amount of work, to turn vision into reality. Basically, the amount of capital (billions) required to build these places is simply too high to be obtainable. It is awfully hard to make a business case for something new, huge, and expensive. This is why we've chosen an approach which reduces the required capital by several orders of magnitude.

Chapter 44

Areas Of Incrementalism

Here are some specific examples of areas which call for incremental paths. We will keep each path general, not putting them together into a complete plan until the Making It Happen chapter.

44.1 Size and Population

The most general area in which we must be incremental is the size of each project, in terms of cost and number of people. For these reasons, our plan includes a series of distinct stages, each involving a greater number of people.

First we complete a design, and build an aquarium-sized model. Then a pool-sized version. Next we build a habitable Baystead prototype for 5-10 people, anchored in sheltered waters within US boundaries, to demonstrate our seriousness and our design. This is the first point at which we need other people's participation. We just need to find 5-10 people who are willing to live together, and don't mind the level of creature comforts that can be achieved on a fairly small platform. While it will require a rare level of dedication to the concept to join this group of aquatic pioneers, we don't have to find very many such people.

Next we need to find 25-100 people (or the equivalent in timeshares) who weren't quite sure if seasteading was legit before, but seeing the demonstration by the first group, find it worthwhile to participate. They build the first deep-water, self-sufficient seastead. Next we find the 100 people who weren't quite convinced by the small group ... and so on. Smaller steps can be added if necessary.

There is plenty of historical precedent for this strategy of zealots seeding settlements. North America, for instance, was colonized mainly by members of minority religions such as the Puritans seeking to escape persecution. These dedicated folk were willing to put up with the discomfort of pioneering in exchange for religious freedom. The result of this passionate commitment to a cause was, eventually, an increased level of civilization, and a beachhead for the less dedicated to follow.

At every step in incremental development, the standard of living increases due to economies of scale, refinement of techniques, and the network effects of the larger community. Rather than convincing 10,000 people from the beginning, you just keep bringing in those at the margin, who needed things to be just a little bit better to get involved. As interest in seasteading steadily grows, more units are steadily built. Each may cater to a slightly different audience, or experiment with different engineering designs and social systems. They will be modular and eventually cluster together into the grand visions many have proposed.

With advanced technology, the pioneering cycle is much shorter nowadays. It doesn't take centuries to go from Conestoga wagons to skyscrapers, and we'll get to start out with electricity, hot running water, and satellite telephones. But at the beginning, we still must be pioneers. We aren't focusing on these humble first steps because we lack imagination, or don't think a huge luxurious floating city would be amazingly cool. That sea city is our ultimate goal, but it is our firm belief that a sea village must come first - and a single sea house before that.

Although few people are devoted enough to drop everything and go found a new society (or even propose doing so), we think that everyone is, to some degree, a revolutionary. After all, who was the last person you met who was completely happy with everything about their society? While utopia is not an option, we do believe there are some fundamental reasons why seastead societies are likely to work better than terrestrial ones. As experimenting with new social systems becomes cheaper and easier, it will be a viable alternative for an increasingly large segment of humanity.

While our passions and preferences will dictate exactly where along the adoption curve you fall, in the next section we hope to at least convince you that a world with seasteads is a world worth working towards.

44.2 Financial Realism

Many proposed ventures are impossibly large in scale. While grand visions are inspiring, they are difficult to make into reality, especially when the idea is novel and unproven. The Freedom Ship is a classic example. Their proposed mile-long design will cost ten billion dollars (\$10,000,000,000.00). That sort of funding is not easy to get, to say the least, especially for a piece of property that might be destroyed by a storm (imagine the insurance premiums!). Things are made even worse because the only previous floating condominium ship, ResidenSea, lost a substantial portion of its quarter-billion dollar cost, even though it had sold many of its units in advance. It seems pretty unlikely that an investor will put up 40 times as much to try again.

Our designs are much smaller, and thus the path to funding them is much clearer. Our current estimates suggest that a complete, viable seastead for around a hundred people could be built for one one-thousandth of the Freedom Ship's proposed cost, or about \$100,000 / resident. Our platforms may not be a mile long, but which do you think has a better chance of getting built? We'll take modest and real over huge and imaginary any day.

Past attempts to raise money from the community of nation founders have demonstrated the folly of depending on this small group. Those with substantial assets, usually older, are generally unwilling to drop their lives (homes, businesses, families) and move. Those with time and mobility, usually younger, rarely have the necessary cash. A viable project must find ways for both of these groups to participate. More importantly, it needs to draw interest from a much broader market. To put substantial effort into a nation-founding project, one must be a zealot of some type, and it is easy to ignore the less-zealous masses. The new territory must be interesting to more than the few eager separatists.

We believe that seasteads will appeal to a large group of customers, for reasons explained in detail in the Market section. One key device is a timesharing system, which lets people participate without having to lay their lives, fortunes, and sacred honor on the line right from the start. We think a graduational transition from traditional ways of life to our pioneering one is required for it to appeal to a significant number of people.



44.3 Sovereignty

Sovereignty

A major issue facing prospective attempts at autonomy is obtaining sovereignty, which terrestrial governments are notoriously reluctant to sell, or recognition, which they are reluctant to give. Some examples discussed in the Review section include Minerva, Cortes Bank, and Laissez-Faire City. Thus we don't think a realistic project should depend on obtaining sovereign land.

In the past, pioneers and malcontents would head to the frontiers, but few remain. The oceans, which make up 71% of the earth's surface, have always been a place for those seeking new ways of life. They are the last great unclaimed region. Ships are not well suited for permanent living (although there is a subculture of live-aboard boaters [Hill1993]), but by creating new land on the oceans we can attain a reasonable combination of freedom and comfort.

Freedom of movement and self-sufficiency are both intimately connected with political freedom. Fixed locations such as seamounts, islands, and atolls are much more vulnerable to the whims of nearby governments, but a mobile seastead can always move if the political climate becomes unsuitable. While a seastead is likely to import many goods, being able to supply its own basic necessities will also add greatly to its independence. This is why seasteads are to some degree self-sufficient, and either roving or at least movable if necessary. This approach to nation founding reduces - but does not eliminate - the difficulty in finding sovereignty by operating in international waters. Further discussion of maritime law can be found in the Ocean Environment - Politics section.

A crucial part of our political realism is modesty in our goals. We won't start out demanding recognition from other nations, acceptance of our passports, or a seat in the UN.

We'll ask only to be left alone to experiment with our pioneering lifestyle in peace. Frankly, we think it's absurd for projects in the planning stage to focus significant effort on these matters. It's like an American pioneering family who are planning their move west to an unsettled region thinking about how to get formal recognition as a state, when they should be worrying about cabins, crops, and packing their Conestoga wagon. The trappings of statehood can come later (if ever) when it is obvious that a group of seasteads qualifies as a country by any reasonable definition.

44.4 Distance

As you'll read about under Ocean Environment, the farther one is from shore, the harsher the conditions. The waves are bigger, you are more remote, and further from help. Thus we recommend the following steps:

1. Early experimentation with seasteads should be done in sheltered waters, such as bays.
2. Next comes part-time presence in the ocean, such as prototypes that live in bays but venture out to the ocean for testing. Ships also go in this category, as they are designed to shelter in harbors.
3. Permanent coastal presence is another possible step, although it is not likely to be used much.
4. Permanent presence outside territorial waters (12nm) will be a big step towards independence. This is still within the EEZ, which means that only ships are autonomous, and artificial platforms are regulated.
5. Permanent presence greater than 200nm from land, outside the EEZ, will be the final step.

All of these can even be followed by the same structure! See the CoHousing Seastead path discussed below for an example.

44.5 Implementation Incrementalism

Incremental Prototypes

TODO: Update this with current thinking. Advantages of coaststead (large potential scaling). Importance of breakwater stage. Baystead / Single-Family Seastead

Large things tend to grow organically, rather than being monolithically designed and built. We believe that focusing on grand results has two detrimental effects on a project: it distracts people with fantasy and it intimidates them from doing real work. By dividing our vision into workable chunks, each of which builds on the last, it has a much better chance of becoming reality. By keeping the initial costs low, it is possible to build the initial versions and show potential investors what they are getting into at each step of the way.

We see the succession of seasteads as something like:

Bathstead

This is little more than a small model that floats in a bathtub or an aquarium. It is used

Poolstead

This is a 1-2 m² platform that floats in a pool. It demonstrates basic stability and flotation.

Baystead

This is the first habitation-sized platform, which is designed to live in sheltered waters.

Coaststead

This is a tall, multi-level platform that can be towed out to the coastal regions of the world.

Seastead Lite / Medstead

Locations such as the Mediterranean and Caribbean Seas are partially sheltered, and an excellent starting point.

Deep-Seastead

This is the final version with a column hundreds of feet long and lots of living area, in deep water.

Each prototype will be larger, more expensive, able to deal with larger waves, and be more self-sufficient. While early ones may be built by volunteers, once we reach the Baystead or Coaststead stage, professional engineers and contractors will be hired. With enough interest and experienced engineers, it may be possible to jump directly to Baystead. While this may seem contrary to the succession idea, note that Baystead is still ten thousand times cheaper than the Freedom Ship - so we think it's a reasonable starting point.

If we had to select an initial site for a prototype seastead to be anchored, we would probably select either the San Francisco Bay Area or the Puget Sound. Why? The computer industry has generated a simply astonishing number of individual multi-millionaires in the San Francisco Bay and Seattle areas. The future phases of seastead development could definitely benefit from the positive attention of a few millionaires. By locating the initial seastead prototype in one of these two areas, it is far more likely that one of these multi-millionaires will become interested in the seasteading project. Also two of the papers authors, Wayne and Patri, live in the SF Bay Area.

For credibility reasons, it is crucially important to have a large, self-funded prototype like Baystead or Coaststead before trying to attract people interested in larger platforms. There have been so many failed nation-founding projects that we must make a concrete demonstration that seasteading is different if we expect anyone to take us seriously. Such a prototype is likely to result in a lot of media attention. For example, Andrea Zittel described her [Pocket Property][[refs.html#PocketProperty](#)] experience in an interview:

AZ: Another problem was that I had fantasized about being completely alone on it in order to recover from a really hectic year. Instead, when I got out to the island, it seemed like every single boat owner in Denmark came out to circle my island while drinking a six-pack of Danish beer. Every time I came out, they would all wave and ask what I was doing. After a while I just felt so overexposed that for the next project I've chosen a piece of land out in the desert, where no one will see me and I can finally be completely alone.

SB: You thought you were hiding, or going away to be alone, and all of a sudden you were on display and less alone than had you just stayed at home.

AZ: I was like a freak show out there!
 - [\[\[Bomb2001\]\]\[refs.html#Bomb2001\]](#)

Incremental Infrastructure

It is not only the seasteed structures which will proceed incrementally. Part of the essential nature of a seasteed is to provide infrastructure where it previously did not exist. But to build infrastructure takes infrastructure, so this process will also be incremental. By infrastructure we don't just mean utilities, but all of the services which help a city to function.

Initially, the level of infrastructure on a seasteed will be low, and services will be expensive. Thus it behooves the developers to start with the businesses which least rely on infrastructure, or benefit the most from the seasteed environment. With these businesses operating, the seasteed can expand. Now experience and economies of scale will lower the infrastructure costs, allowing a wider range of businesses to be cost-effective. And so on.

This is the same organic way in which real cities grow. New York did not start with skyscrapers, it started with pioneers. Seasteeds will be able to progress much more quickly, but they must still go through the same incremental process. If it sometimes seems like we focus overly much on the initial, rough levels of infrastructure, it's not because we don't want to build a floating Hong Kong. It's because this is what's required at the beginning, and the beginning of nation-founding appears to be very difficult. We believe it's vital to focus on starting the process, and not be too distracted by visions of the end results.

Eric Hunting suggests an interesting strategy for incremental growth of a floating city. Rather than building the city all at once and immediately towing it into location, build it piece by piece close to a major city. Residents slowly and steadily move on-board, while still having access to the infrastructure of civilization, which serves to supplement and back up the developing infrastructure of the new colony. This allows people to get to know each other, get used to self-sufficiency technology, and steadily transition their work to the new economy. As various milestones are reached, the growing structure can be moved farther away. Eventually, when it is complete enough, the colony can be towed to its final location. [\[\[Hunting2001\]\]\[refs.html#Hunting2001\]](#)

A possible variation is that instead of moving away the entire colony, the initial "seed" unit could remain behind, to start the growth of another city. People who were not yet ready to leave could stay with the seed.

Incremental People

The same ideas that apply to incrementally growing infrastructure apply to growing the seasteed population. The initial seasteed environment will be high in freedom but low in infrastructure. Thus we must start out with the few enthusiasts willing to trade comfort for

freedom. They will create an environment of higher comfort, and can bring in those who need that higher level. The process repeats, with each expansion lowering the costs and increasing the comfort, and thus making possible the next expansion.

Similarly we anticipate that many of the initial residents will live onboard only part-time. (Many more people vacation in rustic cabins than live in them year-round). But their presence and economic contributions will allow the colony to grow, and thus make it more suitable for full-time residence. While seasteads are not terribly expensive compared to first world housing, timesharing aids with two potential financial roadblocks.

One is that mortgages will not be available for quite awhile, so individuals will probably need to pay up front. Timesharing means that they can steadily pay for more and more shares until they are full-time. This is not as convenient as a mortgage, since the person can only live there as often as they've paid for instead of moving in at the beginning and paying interest. But it's still better than having to pay the whole thing before enjoying any of it.

The second is that the number of jobs onboard will be limited at first. This especially applies to high-paying jobs, which tend to be in specialized fields which require a large population to support. So the prospective full-time seasteader must either be independently wealthy or be able to run a business on board. While there will be some people like this, it's a small market. Timesharing lets people earn their main income elsewhere while the internal economy develops.

Chapter 45

Our Proposals

We now proceed to get more detailed, and describe the specific approach we feel is the best way to make seasteading happen. While this particular plan will take a lot of work and needs a lot more fleshing out, we do not believe that it involves any miracles. It does not require a billion-dollar investor or loan. It does not require ten thousand (or even a thousand, or a hundred) people to leave their lives and move permanently into the middle of nowhere. It does not require the technology of tomorrow, only of yesterday and today. Nor, we must humbly add, is this because of any particular brilliance on our part. We've simply done the research, evaluated the alternatives, and made our choices based on realism, not romance.

We propose the founding of the Seastead Development Corporation, whose goal will be to make money by building seasteads. A small group of devoted people, including SDC's founders, will be its first customers, buying the Coaststead prototype. SDC's capitalization beyond this will be quite small.

Coaststead will be permanently moored, most likely in the San Francisco Bay. It will be open to tours by those who are interested in learning more about this new way of life. The goal is publicity and creating a market for the next product, timeshares on Seastead I, a full-size self-sufficient deep-ocean platform. Think of Coaststead as a floating Goodyear Blimp. Having built an actual structure, we will have made more progress than 99% of all nation founding attempts, which gives us credibility.

We believe that there is a substantial market for timeshares in Seastead I. We will not be requiring a whole-life commitment, a large amount of money, or dedicated volunteer labor from our customers. We will not ask for a major leap of faith on their part, as a 1,000,000 pound token of the practicality of our vision will be floating under them while they ponder the idea.

When enough deposits have been made and contracts signed with residents, construction on Seastead I will begin. At this point, with the first seastead funded, the hardest part of the work has been done, and the movement can take off on its own steam. Once an operating Seastead I is demonstrating that seasteading is technologically, financially, and politically feasible, interest will continue to grow.

As seacities develop, the seaconomy will grow, and seasteading can become a full-time way of life for an increasing number of people. Different political and legal systems will be experimented with, and the most successful emulated. Seasteads will have become, not a utopia (which is impossible), but an incremental improvement, a freer and more adaptable form of life. That is our goal. But while we must keep it in the back of our mind, our focus

should be on the next couple steps. Thus we proceed to your contribution and then a more detailed business plan.

Let us compare this strategy with the strategies being employed by the Atlantis, Millennium, and [New Utopia projects][]. All three of these projects require significant up front investment from investors. Which strategy do you think has a greater chance of happening? A bootstrapping process from small prototype seasteads or going straight to the ultimate city on an artificial island that skips all the intermediate steps? Our opinion is that the bootstrapping process is far more likely to succeed.

45.1 TSI's Proposed Timeline

Seasteading: A Possible Timeline

Note: This section has not been updated since the founding of [The Seasteading Institute][]. We have added sections containing TSI's proposed timeline and 2-year strategy for 2009-2010 to supplement the original material.

The Seasteading Institute
Updated March, 2009

The Seasteading Institute's mission: To establish permanent, autonomous ocean communities to enable experimentation and innovation with diverse social, political, and legal systems.

About the Timeline

The purpose of this timeline is to put forth a vision that is more detailed than our mission statement. The intent is not to lock ourselves to a particular set of steps or expectations, but merely to align our organization and community in the same general direction as we begin to walk this path together.

This document describes what might be achieved, but not much detail about how we hope to get there. There are multiple paths to TSI's vision, and we intend to pursue them all in parallel. For more information about our overall strategy, and how we intend to grow the seasteading movement in the near term, please see our (soon-to-be-published) strategy document.

Obviously, this timeline is highly speculative! It is hard to say how seasteading will unfold even 5 or 10 years out, much less 50 or 100. The goals and approaches described here will almost certainly change substantially as the seasteading movement evolves.

For general background about seasteading and TSI, please see our introduction and FAQ.

Seasteading: A Possible Timeline

2 years from now:

- Seasteading population:
 - 1 rugged individualist living full-time on a seastead.
- Residential sector:
 - The first seasteader has provided a living proof-of-concept for the idea of residential seasteading.
 - TSI has created a prototype single-family seastead in the San Francisco Bay.
- Commercial sector:

- The first boat-based business which is directly adaptable to a seastead is operating.

- Legal landscape:

- Experts in maritime law are actively involved in the movement, and have produced a formal report with an initial assessment of seasteading's legal landscape.

- TSI's focus:

- Community: Growing a global community of seasteading supporters to generate awareness, support and funding.
- Growth: Working to help a few pioneering ocean-based businesses (which should be adaptable to seasteads) get off to a successful start. (See note below)
- Engineering: Prototyping small seasteads, both centrally through TSI and through distributed community efforts. Ongoing R&D on commercial and residential seastead designs.
- Legal: Investigating legal questions pertaining to seasteading.

5 years from now:

- Seasteading population:

- At least 10 full-time seasteaders worldwide.

- Residential sector:

- Pioneers only, primarily on small, custom-made seasteads.

- Commercial sector:

- Ocean-based business models have been successfully run on ships.
- A few seastead-based businesses have very recently formed, or are in the process of forming.

- Legal landscape:

- The legal questions and challenges facing seasteads are well understood with help from qualified legal experts that have experience in maritime law.

- TSI's focus:

- Community: Growing a global community of seasteading supporters to generate awareness, support and funding.
- Growth: Actively encouraging, advising, and otherwise supporting the formation of new ocean-based commercial ventures. (See note below)
- Engineering: Performing ongoing R&D on commercial and residential seastead designs.
- Legal: Investigating legal questions pertaining to seasteading. Early discussions about seasteading with the U.S. government.

10 years from now:

- Seasteading population:
 - At least 250 full-time seasteaders worldwide.
- Residential sector:
 - The residential sector is still growing extremely slowly, and mostly consists of individual pioneers and employees on seastead-based businesses.
- Commercial sector:
 - A number of seastead-based businesses are successfully operating.
- Legal landscape:
 - Meaningful, open dialogues have been happening with relevant departments of the U.S. government and the United Nations.
 - Substantial clarity and awareness is being created in international maritime law about the legal status of seasteads.
- TSI's focus:
 - Community: Growing a global community of seasteading supporters to generate awareness, support and funding.
 - Growth: Actively encouraging, advising, and otherwise supporting the formation of new seastead-based commercial ventures.¹
 - Engineering: Performing ongoing R&D on commercial and residential seastead designs.
 - Legal: Spearheading ongoing legal discussions about seasteading with the U.S. government.

15 years from now:

- Seasteading population:
 - At least 3,000 full-time seasteaders worldwide.
- Residential sector:
 - Issues of safety, legality, cost, and comfort are addressed enough to make residential seasteading communities practical.
 - Residential seastead villages have begun to form.
- Commercial sector:
 - Seastead-based business has started to gain its own momentum - many seastead-based businesses are forming, often without encouragement or involvement from TSI.
 - An industry coalition has formed of seastead-based businesses to provide mutual support and unified representation to government and the general public. TSI's support is less needed.

- Legal landscape:
 - A legal framework (possibly flags of convenience) giving seasteads a reasonable degree of operational autonomy has been upheld in US or international courts of law.
- TSI's focus:
 - Growth: Focusing on global public awareness; helping the business world understand the competitive advantages and practical approaches to seasteading, and helping global citizens understand why life on a seastead might be right for them.
 - Support: Supporting seastead communities in the areas of establishment, law, activism, and civil scale.
 - Engineering: Decreasing focus on engineering R&D as progress by for-profit seastead manufacturers accelerates.
 - Legal: Beginning to fully engage other governments around the world about legal implications of seasteading.

20 years from now:

- Seasteading population:
 - At least 20,000 full-time seasteaders worldwide.
- Residential sector:
 - Many small seastead villages and towns exist in different regions around the world.
- Commercial sector:
 - The commercial seasteading sector has strong momentum of its own. The business world is starting to take notice and help evangelize.
- Legal landscape:
 - The U.S. government has a friendly or neutral policy towards seasteads.
- TSI's focus:
 - Growth: Focusing on global public awareness; helping the business world understand the competitive advantages and practical approaches to seasteading, and helping global citizens understand why life on a seastead might be right for them.
 - Support: Supporting seastead communities in the areas of establishment, law, activism, and civil scale.
 - Legal: Global activism and government relations in support of the seasteading movement.

25 years from now:

- Seasteading population:

- At least 100,000 full-time seastealers worldwide.
- Residential sector:
 - There is at least one seastead city of 20,000 residents or more.
- Commercial sector:
 - The first large, established corporations are starting to open major offices on seasteads as jurisdictional arbitrage increases the competitive advantage of operating on the ocean.
- Legal landscape:
 - There is general consensus among seasteading policy experts about a plausible path to sovereignty for seastead city-states, even if it has not yet been achieved.
- TSI's focus:
 - Growth: Focusing on global public awareness; helping the business world understand the competitive advantages and practical approaches to seasteading, and helping global citizens understand why life on a seastead might be right for them.
 - Support: Supporting seastead communities in the areas of establishment, law, activism, and civil scale.
 - Legal: Global activism and government relations in support of the seasteading movement.

50 years from now:

- At least 5,000,000 full-time seastealers worldwide.
- Some seasteads are generally recognized as sovereign states by other world powers.

75 years from now:

- At least 75,000,000 full-time seastealers worldwide.
- At least one seastead city-state is considered a notable world power.

100 years from now:

- At least 500,000,000 full-time seastealers worldwide.
- The effects of competitive government and fluid geography are readily apparent, and are openly discussed by world leaders as a significant factor in shaping their own policy decisions.

Note: For legal reasons, it is important to clarify that as a non-profit corporation under U.S. law, TSI is limited in the ways in which it can assist specific for-profit companies, as opposed to the commercial seasteading sector in general.

45.2 TSI's Proposed Strategy

Note: This section has not been updated since the founding of [The Seasteading Institute][]. We have added sections containing TSI's proposed timeline and 2-year strategy for 2009-2010 to supplement the original material. The most recent version of the strategy can be [found here online](http://docs.google.com/a/seasteading.org/Doc?docid=dck5q6sr_12cqrdrxf2&hl=en). Below is the strategy as of May 2009: **The Seasteading Institute**

Organizational Strategy **Updated April, 2009**

Contents

1. TSI's Mission and Role

What are we ultimately trying to achieve, and what is our organization's part in the solution?

2. Overall Strategy

What's our overall approach to achieving our mission?

3. Current Strategic Focus

Where should we be focusing our efforts in 2009 and 2010 to best further our mission?

4. Annual Goals

What concrete goals will we set for 2009 and 2010 within our areas of focus?

5. Quarterly Goals

What steps will we take to achieve our annual goals in 2009?

6. Strategic Risks

What are the major risks to our mission, and how will we mitigate them?

7. Conclusion

1. TSI's Mission and Role

What are we ultimately trying to achieve, and what is our organization's part in the solution?

TSI's Mission

TSI's mission is to further the establishment and growth of permanent, autonomous ocean communities, enabling innovation with new political and social systems. By opening a new frontier, we intend to revolutionize humanity's capacity to improve quality-of-life worldwide by creating experimentation and competition among governments.

For a more detailed picture of what this might look like, see *Seasteading: A Possible Timeline*.

TSI's Role

Ultimately, TSI's role is to create the conditions that will make seasteading happen, as opposed to making it all happen ourselves. While we fully intend to "get in the trenches" when necessary, our vision is too large and too diverse to be realized by any single organization. It will take thousands of organizations - corporations, non-profits, and communities - to make this a reality. As a non-profit organization, we will welcome these organizations as partners in our goals.

In the early years, we will jump-start the seasteading movement wherever it needs a boost, whether it's spreading the idea, understanding the legal landscape, or building and

selling the first seasteads ourselves. Eventually, other organizations will begin to form and carry the torch, one example being for-profit seastead manufacturers. Long-term, we will continue to pursue initiatives that have a high centralized cost yet provide great benefits to the seasteading movement as a whole, such as advocacy, research, education, and evangelism.

It's also important to understand that TSI will not operate any actual seasteading communities on the ocean. Central to our vision is the idea of experimentation and competition among new governments and social systems; the power of this vision will be realized only when seasteaders are left to self-organize. Some of the first communities are likely to consist of employees living on a seastead being used to operate a business. Residential communities will create their own means of self-organization (in effect, fledgling governments). Our role is to support these communities however we can, as long as they operate with the consensual participation of their members and are not having an overtly negative impact on the seasteading movement as a whole.

2. Overall Strategy

What's our overall approach to achieving our mission?

Strategic Principles

Additional detail on some of these principles is discussed in our book.

Incrementalism: Much of our philosophy revolves around incrementalism - starting small and building up over time. Unlike previous projects in this space, we aren't expecting the first seastead community to form with thousands of citizens, or to build something by securing billions of dollars in funding. We expect the movement to start small, with individuals purchasing single-family seasteads at prices comparable to San Francisco homes, and businesses investing in seastead-based business models that have already been proven on ships. We also approach our political goals incrementally. **We won't start out demanding recognition from other nations, acceptance of our passports, or a seat in the UN; if this comes, it will take decades. We'll ask only to be left alone to experiment with our pioneering lifestyle in peace.**

Transparency: A solid, realistic plan can stand criticism and review. It is the scams, the half-baked, the grandiose but insubstantial, which must hide behind a facade of mystery. In our experience, the less you see up front, the less there is behind. Sure, it's possible that behind the curtain lies a complex and well-considered plan which is being hidden for some legitimate reason, but the odds are heavily against it. We intend to be transparent in our plans, our successes, and our failures, both to gain our community's trust, and to benefit from their insight.

Realistic compromise: While our goal is to change the world, we believe that compromise is an important part of the process. We accept that seasteads will not have full freedom to choose their own laws. There will be substantial limitations on what the rest of the world will tolerate. This willingness to compromise does not mean that our new way of life offers no improvements on the old, but we think it's far better to get what freedom is possible than to fail because of a refusal to compromise. In the long term, focusing our efforts on a few changes at a time is the most effective way to succeed.

Centralized and decentralized: We think that there are significant strengths to be leveraged from both centralized and decentralized approaches to seasteading problems. To cite just one example, we think it's important to use professional marine engineers to do

detailed structure design and analysis. The ocean is an unforgiving and deadly environment, and the tools to test structures that can withstand it are best left in the hands of professionals. That said, the community is driven by a passion and creativity for seasteading that professionals in established industries may not have, and this may help them find unique solutions to problems. We want to tap this creativity through programs and events like contests, Ephemeral (described below), and so on.

Strategic Paths

We currently see three promising paths to achieve our mission, which we are pursuing in parallel:

1. Seastead-based businesses: Seasteading for profit. Profit is a fantastic incentive for growth, and we expect it to be so for seasteading. The key is finding business models which can create a competitive advantage based on the ocean's unique physical and legal properties. At our 2009 conference, many such ideas were brainstormed and evaluated in a workshop, some with great promise. Growth of the commercial sector can be a major population driver, as people will immigrate to seasteads for live-aboard jobs.

2. Seastead-based homes: Seasteading for personal freedom. In the near-term, this will involve small single-family seasteads, providing a way for the first steps of the seasteading movement to be taken with personal capital. Eventually, we might see larger seasteads which communities purchase and move to as a group. We can seed the path of seastead-based homes from existing communities: live-aboard boaters, libertarians / Free State Project enthusiasts, and so on. As comfort, safety, and cost improve, this will be accessible to more and more people. Small residential seasteads have the additional benefit of risk dispersion - there is not one big seastead for a hostile government to shut down.

3. Seastead-based festivals: Seasteading for recreation. We call them "Ephemeralisles." Picture a temporary festival, its spirit similar in some ways to Burning Man - lots of people, lots of fun, creative art, and a good deal of engineering ingenuity. Ephemeralisles can start in calm waters, and gradually move to international waters over the course of a few years. This path has two key advantages: First, the power of experiences to change peoples' mind is substantial - Ephemeralisles will make seasteading "real" for a large number of people who wouldn't otherwise "get it." Second, it lets us harness the community's creativity to discover and solve practical challenges about the actual, on-the-water seasteading lifestyle. In the long-term, Ephemeralisles could grow in duration and size until they gradually become *de facto* cities.

3. Current Strategic Focus

Where should we be focusing our efforts in 2009 and 2010 to best further our mission?

Focus

What this is

Why this is a focus

1. Awareness and community

Increasing the number of people in the world who are aware of seasteading and their degree of engagement with the movement.

As a non-profit, our success depends heavily on donations of both time and money from others. To find them, we need to quickly grow our community.

This includes both fostering positive public awareness (media coverage, outreach to partner organizations, etc.), and especially fostering the core community of passionate people

who are actively involved in the seasteading movement. As a new non-profit, this must be one of our top priorities.

2. Seeding businesses

Working to help a few pioneering ocean-based businesses (which should be adaptable to seasteads) get off to a successful start.*

With seastead-based businesses as one of the most likely areas of growth in the movement's first decade, this is an important area. Without any seasteads operating yet, it's too early to start actually building a business to run on one - but we can start with boats, focusing on business models that would have an additional competitive advantage when transitioned to seasteads.

3. Engineering

R&D and prototyping of seastead designs, both centrally through TSI and through distributed community efforts.

We think it's extremely important to create real physical seasteads as soon as possible. This promotes public awareness, improves our understanding of what challenges we'll face, and ensures that we don't get caught in the trap of endlessly thinking rather than doing.

4. Legal exploration

Investigation of legal questions pertaining to seasteading.

Addressing the legal and political issues facing seasteading is going to be an extremely long process with many surprises. It's important that we start to understand the landscape now.

** For legal reasons, it is important to clarify that as a non-profit corporation under U.S. law, TSI is limited in the ways in which it can assist specific for-profit companies, as opposed to the commercial seasteading sector in general.*

4. Annual Goals *What concrete goals will we set for 2009 and 2010 within our areas of focus?*

The seasteading movement is evolving very quickly, and we're constantly exploring many areas which might yield important strategic developments. A major source of additional funding, a new ocean-based business idea, or discoveries in the legal landscape are just a few examples. However, windy seas are no reason not to chart a course, and so we've laid out some key goals based on the landscape as we see it today. Even if we should need to change these, it's likely that our near-term strategies will involve many of the same elements described here.

2009 Goals: Build a foundation for the seasteading movement and community

- **Building awareness and support**
- Successfully hold the first Ephemerisle festival and the second Annual Conference
- Have at least 100 paying members of TSI and 3 regional chapters
- Average at least 3500 website visits per day by end of year
- **Seeding businesses**
- The first boat-based business which is directly adaptable to a seastead has secured funding

- **Engineering**
- Publish a new (post-ClubStead) seasteed design
- Launch a community-driven R&D program
- Complete design work for a prototype seasteed to be placed in the San Francisco Bay
- **Legal exploration**
- Produce an informal whitepaper giving a brief overview of seasteading's legal landscape
- **Financial**
- Have at least one year of cash reserves on hand
- Receive \$100,000 in donations

2010 goals: Make seasteading a reality

- **Building awareness and support**
- At least 1 individual is living full-time on a seasteed
- Successfully hold Ephemerisle 2010, in conditions closer to the high seas than Ephemerisle 2009
- Get significant coverage in a major media outlet such as the New York Times or CNN
- Have at least 250 paying members of TSI and 15 regional chapters
- **Seeding businesses**
- The first boat-based business which is directly adaptable to a seasteed is successfully operating
- **Engineering**
- Build a prototype seasteed in the San Francisco Bay
- **Legal exploration**
- Produce a formal report with an initial assessment of seasteading's legal landscape, and well-researched options for navigating it
- **Financial**
- Increase annual rate of income from 2009 to 2010

5. Quarterly Goals

What steps will we take to achieve our annual goals in 2009?

Q2 2009: Continue focusing on community growth

- **Building awareness and support**
- 50 TSI members, 1000 mailing list subscribers
- Complete Patri's first speaking tour (U.S. East Coast and Europe)
- Website improvements: Front page redesign, blog launches & upgrades
- **Seeding businesses**
- Create a strategy for how to most effectively foster the commercial seasteading sector as a non-profit*
- **Engineering**
- Begin design work for next model of seastead
- Launch an Ephemerisle "Do-it-yourself (DIY) seasteading" contest to promote the DIY movement
- **Legal exploration**
- Complete broad overview whitepaper of legal issues, challenges, milestones
- **Financial**
- Prepare fundraising program (potential key donors, strategies to contact, money-bombs, etc.)
- **Administrative**
- Launch internship program
- **Publish 2009 annual report Q3 2009: Begin additional fundraising and continue growing the community**
- **Building awareness and support**
- 75 TSI members, 1500 mailing list subscribers
- July 4th publicity push
- Launch TSI chapter program before the start of the new school year
- Complete pitches to book publishers
- **Engineering**
- Create a high-level plan for prototype construction (budget, funding, personnel, etc.)
- **Financial**
- Launch targeted donor appeal program
- **Administrative**
- Build out our Board of Directors with new high-level seasteading supporters

- Receive our 501(c)3 status from the IRS

Q4 2009: 2009 Conference and Ephemericale and new seasteed design work

- **Building awareness and support**
- 100 TSI members, 2000 mailing list subscribers
- 3 regional chapters in place
- Hold 2009 conference and 2009 Ephemericale (a floating festival for seasteaders)
- Launch a Free State Project-style program for people interested in living on seasteeds
- **Seeding businesses**
- The first ship-based business which is directly adaptable to a seasteed has secured funding
- **Engineering**
- Complete and publish new seasteed design
- Test community DIY seasteed designs at Ephemericale
- **Legal exploration**
- Produce second whitepaper, giving a more detailed description of seasteading's legal landscape and strategies
- **Financial**
- Reach \$100,000 in donations

6. Strategic Risks

What are the major risks to our mission, and how will we mitigate them?

In this section, we explore what we consider to be the major risks to the successful development of the seasteading movement. For each risk, we describe it in detail, assess its likelihood, and most importantly, explain what steps can be taken to mitigate it.

Risk: Intervention from existing governments may make it difficult or impossible for seasteeds to innovate politically, or even to operate at all.

Explanation: At the beginning of the seasteading movement, many seasteeds are likely to operate close to existing countries for reasons of safety, economics, and convenience. These seasteeds will be subject to some laws from the neighboring country, whose jurisdiction extends, in some cases, up to 200 miles past their shore. That country's government might interfere with the seasteed's affairs if the seasteed breaks their laws - intentionally (which TSI wouldn't recommend, but might happen regardless) or unintentionally (since seasteeds will, to some extent, be operating in uncharted legal territory.)

Even if a law is not being broken, these neighboring governments might feel a seasteed is breaking the spirit of their laws in a way that adversely affects the nation's interests. An extreme example would be a seasteed which sits right outside the border of that country's legal

jurisdiction and starts manufacturing and exporting an illegal drug to that country. One can also imagine countless less black-or-white examples where the likelihood or nature of a government response is harder to predict. For instance, what if the drug in question is prescription painkillers? What if the seastead is a hundred miles out of the nation's jurisdiction, or a thousand? What if the drug in question is MDMA, and is being used for therapeutic purposes to treat PTSD?

Yet another possible cause of government intervention is special interests. One example of this is a seastead-based business that begins to take away market share from powerful, entrenched industries in a nearby nation. These industries can obviously influence political policy, even if laws are not being broken and public opinion is supportive.

Likelihood: In our opinion, this is probably the largest risk the seasteading movement faces.

The risk is greater when seasteads are closer to an existing country. Because being close to existing countries is so beneficial to the success of early seasteads, this risk requires careful attention during seasteading's early years.

Mitigation: * * ***Understand our legal status and don't break the law.** Flagrantly disregarding the law is a great way to invite intervention - whether for breaking the law itself, or just as a convenient excuse to act on some other motivation.

- **Realistic compromise.** This is one of our strategic principles, and it strongly applies here. It's better to have whatever additional freedoms is practical, than to lose them all because we're unwilling to compromise.
- **Proactively discuss potential issues with neighboring countries.* *In most cases, transparency is more likely to help a seastead than to hurt them - if a seastead tries to hide something from a government, they will almost certainly find out eventually anyway, and be angrier when they do.
- **Establish positive-sum relationships with neighboring countries.** Nations, like people, respond to incentives, and if we can further a nation's interests, they'll be less likely to interfere with us. Trade, especially that which provides valuable and unique goods and services to influential people in the nation in question, is one way to do this.
- **Diversify the movement's risk.** Encourage the establishment of seasteads around the world, so the movement is not overly dependent on the whims of a few nations.
- **Achieve greater autonomy.** Long-term, as seasteads become more self-sufficient, proximity to existing countries is less important. Moving further away will greatly reduce the risk of intervention from existing governments.

Risk: Seasteads might prove too cost-prohibitive to catch on for the foreseeable future.

Explanation: Low cost fuels growth, and it's hard to be certain about the cost of a technology that hasn't actually been built yet. Cost issues might arise at any stage of seasteading's development. For example, we could discover unforeseen technical challenges while constructing the first seastead that could drive the cost up. Or we might discover that artificial breakwaters, one of the key ideas for building a large seastead city at a reasonable cost, are not practical.

Likelihood: This is a moderate risk, though not an extreme one. Much of the technology is very similar to that used for cruise ships, which can house people for as cheap as \$60/night (though admittedly with less comfort than on land). We have done a detailed

engineering design that projects the cost of a hotel resort built on a seasteed (\$259/ft²) will be substantially less than home prices in San Francisco (\$517/ft² as of April 2009). Less analysis has been done on breakwaters so far, so this is a larger risk.

Mitigation:

- **Professional, detailed engineering design.** This help us understand the cost of building seasteeds with a greater degree of confidence, so that we can identify and address any risky areas.
- **Tap the community’s creativity where conventional engineering approaches fail.** The Ansari X PRIZE is a great example of this. By offering a \$10 million prize, the X PRIZE Foundation was able to spur innovative spacecraft designs that could be built for drastically less money than they could by the massive government agencies who had always pursued spaceflight.
- **If all else fails, wait for technology to improve.* **While not an exciting solution, the cost is certain to drop given enough time.*

Risk: There might be a lack of demand in using seasteeds for residential and/or commercial purposes.

Explanation: For a number of reasons, seasteading just might not appeal to very many people. The early pioneers in particular will face a difficult lifestyle, and that cost might prove so limiting that seasteading never takes off. Perhaps more importantly, people have very strong ties to the area in which they live. Their extended families, and personal and professional social networks, are largely based in a particular area. Finally, many land-based governments are very established and very stable, which creates security that may not be present in early seasteed city-states. This is appealing to many people - even ones who don’t like their government.

Likelihood: The risk of the ”high cost of pioneering” does not seem particularly high; pioneers have always faced a difficult lifestyle, yet they have settled new frontiers regardless. As new frontiers build up, they become less risky, and more and more people have found it worthwhile to settle them, seeking whatever unique properties that frontier offers.

The risk of low demand due to ”land stickiness” is a moderate risk. People have a great deal invested in their existing lifestyles.

Mitigation:

- **Incrementalism.* **The more seasteeds there are, the more appealing it becomes - they are cheaper, the technology is more proven, the means of being financially self-sustainable are better established, and there are more other seasteaders to form communities and partnerships with. If our strategies cannot evolve incrementally, the seasteading movement may encounter a hurdle which it doesn’t have enough momentum to overcome. Witness the Freedom Ship’s \$10B funding requirements.*
- **Ensure the success of the commercial sector.* **Settlement of new frontiers is often driven by the promise of profit. The seeds of new communities are formed by entrepreneurs and their employees.*
- **Reduce the quality-of-life gap between seasteeds and land.** Residential seasteading is not only an engineering problem, it is a lifestyle problem. Emphasis on interior design, landscaping (e.g. Royal Caribbean’s Central Park), and functional luxuries can create a substantial improvement in living experience at a modest increase in cost.

Risk: There might be massive public resistance to the idea of seasteading.

Explanation: This might happen in a number of ways. Some people simply find certain lifestyle decisions morally objectionable, even when those decisions don't affect them. In this context, a system which creates more freedom for people might be viewed negatively. Other people might fear that seasteads will cause them, or people they know, more harm than good, due to unsafe conditions, facilitating unhealthy behavior, or providing a haven for groups with dangerous motives.

Likelihood: Early press about seasteading has been extremely positive, which is a good sign. However, it is virtually certain that major concerns will escalate as seasteading changes from a fun, creative idea in the far-off future to something more tangible and immediate. Concerns are possible in almost any area that is more heavily regulated in first-world countries than they would be on a seastead.

Mitigation:

- *Public education.* *Part of TSI's role will be to create awareness about the positive benefits of seasteading, and reasons why the risks and disadvantages are manageable.
- **Realistic compromise.** Again, we come back to one of our strategic principles. Some PR issues might be best handled simply by giving in. It would be wise of early seasteads to choose their battles, rather than trying to win every single one. TSI intends to choose wisely when advocating for the seasteading community.
- **Help good seasteads succeed.** As with any technology, there will be some who apply it in ways that do good, and some who apply it in ways that cause harm. The more effectively we help the good seasteads succeed, the more benefits there will be to be observed and appreciated.

Risk: There could be an accident or disaster on a seastead with major human casualties or financial damage.

Explanation: The ocean is a dangerous environment. There are massive waves, hurricanes, and even pirates. If major disaster strikes a large seastead, the PR backlash could be very damaging. Examples might be deaths at an early Ephemeral festival, a large seastead destroyed in a hurricane, or an act of organized human violence against a seastead.

Likelihood: Most of these scenarios are unlikely to become issues. Our book talks at length about effectively handling waves and storms, and the minimal risk that pirates pose to seasteads. However, they are not impossible.

Mitigation:

- Use seastead designs that undergo verification and testing by professional engineers. These folks keep oil rigs and cruise ships safe - they've got lots of practice and expertise on their side.
- Take an incremental approach to dealing with weather. Initial seasteads are likely to be placed off the Southern California coast, where ocean weather is gentler. The equatorial doldrums, or other areas with calmer weather, are also places where the safety of new seastead designs can be tested in real living conditions with less risk.
- Educate seasteaders about prudent means of self-defense. Just because piracy seems very unlikely doesn't mean that security is unimportant. Part of the support and education TSI can provide to the seasteading community is how to provide effective security at a reasonable cost.

7. Conclusion

With this strategy in place, we expect 2009 and 2010 to be an extremely productive and exciting time for the seasteading movement. Grounded in clear strategic principles - incrementalism, transparency, realistic compromise, and balanced centralization and decentralization - we've charted a path that's going to make real progress. This path is clearly defined, realistic in scope, and has measurable results.

Within two years, we'll see the first seastead floating in the San Francisco Bay. We'll see the commercial seasteading sector in its infancy, beginning operation on ships. Real progress will be made understanding our legal and political challenges. And the community will really take off; Ephemerisles will be happening, a large TSI membership will be built, and we'll have lots of strong, wide-reaching press coverage. What's more, we'll be well-positioned to lead the movement into its next phase, with a strong team built here at TSI and significant funding from new major donors.

In short, we'll be well on our way to making this vision a reality.

We invite your feedback on our strategy. Please feel free to send any comments to strategy@seasteading.org.

45.3 Something to Breakwater

45.4 Ephemerisle

Ephemerisle Intro

Ephemerisle: A Festival Of Commerce And Self-Government

Imagine being at the first Burning Man...except it's someplace even bleaker, harsher, and wide open, with less rules. Where it can scale without local law enforcement getting involved. Like I said, if we do this thing...this is some seriously crazy shit, folks. If you like crazy, and anarchism, and changing the world, you ain't gonna wanna miss it. This is where it all begins to be real. Ideally w/o too much loss of life :).

I want to live in freedom (by which I mean at least libertarianism, if not anarcho-capitalism). Unfortunately, no such political system is implemented on a significant scale anywhere in the world. Fortunately, there are lots of other people who claim to be interested in the same thing. It seems like you ought to be able to just start a new country (read more on my desire/reasons to do this). Unfortunately, it turns out to be hard. I mean, really hard. Sealand somewhat succeeded, but Oceania, SeaState, Transtopia, The Freedom Ship, and Laissez-Faire City are all examples of visions that have so far failed to become reality.

I think that these projects all suffered from too much ambition. They attempted to tackle a difficult problem all at once, rather than dividing it into realistically small pieces. Realistically small, for a country, may not merely mean space, it may also mean time. Rather than attempting to solve the paradox of finding good land that no government wants, or the thorny engineering problems of building economical barge-cities or floating platforms, I propose the Ephemerisle: a temporary, autonomous, anarcho-capitalist community in international waters (fuller description).

Many critics of anarcho-capitalism have pointed out, quite correctly, that it is an almost purely theoretical system. How do we know that it can work if its never been tested?

This argument makes sense, and given the difficulty of convincing people to move to some remote corner of the earth in order to test out a new political system, the question is: how can we get there gradually? In an interview, David Friedman proposed one method: "My ideal path to anarcho-capitalism would be one in which private institutions gradually replaced government institutions, so that when the state finally vanished nobody noticed. An entertaining tongue-in-cheek version of such a society is described in the science fiction novel *Snow Crash*. "

While the sit and wait attitude is easy, it is slow and not guaranteed to work. Governments have managed to keep a pretty tight grip so far. The Ephemerisle approach is more aggressive than just continuing to develop theory, more timely than agitating for our neighbors to see the light, and more realistic than trying to convince a government to give up sovereignty at an affordable price.

The Ephemerisle is a proposed gathering in international waters for the purpose of experiencing freedom and learning more about anarcho-capitalist interaction. Basically, a bunch of people in boats travel to someplace outside governmental jurisdiction and hang out for a week or two. Kinda like the various ship city and found your own libertarian country projects that have been attempted, or the Raft from *Snow Crash*, except temporary and initially much smaller in scope. It's like the Burning Man or Maker Faire, but instead of being about artistic self-expression or technology, it's about radical political expression and DIY politics and societies.

Bold bulleted buzzwords: * Experimental - Rather than just theorizing about political systems, lets try them out.

- Temporary - Because it will be easier to get people to go someplace for a week than to move there permanently.
- Autonomous - It is the quest for freedom which is the Ephemerisle's inspiration. How can we truly experience freedom or explore anarcho-capitalism within the boundaries of a coercive government?
- Anarcho-capitalism - A theoretical political system based on freedom and consensual, contractual interactions. Perfect for governing an eclectic, temporary gathering subject to no land-based jurisdiction.
- Community - By gathering and inspiring lovers of freedom, the Ephemerisle will help them on the path towards eventual permanent autonomy.

Maybe anarcho-capitalism doesn't work. Maybe we really do have more freedom inside national boundaries. Maybe freedom isn't worth the loss of safety. Maybe no one is really that interested in moving to a new country. Maybe it will be too dangerous. Maybe existing governments won't permit autonomy.

Let's find out the size and shape of the obstacles we face. All of these potential problems seem, to me, more surmountable than converting the american public to anything resembling libertarianism.

Visions

Here are some brainstorms I've had about neat things that could happen at this event. Some of them may not be realistic, especially for the first Ephemerisle, but hopefully they will serve to inspire others to help turn visions into reality.

- Intranet - This would be a fundamental enabling technology for the event. Communication would greatly aid market-based coordination and the anarcho-capitalist legal system. Wireless seems like a good way to implement this, probably 802.11, which can get a 1mile radius on a flat surface with a high, amplified antenna. A protocol that was conducive to cryptography and robust against malicious attacks would be a plus.
- Digital Cash - With a data network, digital cash becomes possible.
- Digital Reputations - An eBay-like digital reputation system could be developed, and used to help enforce court decisions and consensual interactions. Maintain a web of trust so people can see what links of trust they have to each other.
- Lots of other digital-society stuff like arbitrators, certificates, and timestamps.
- Anarcho-Capitalist institutions - The above would make it easier to interact through a market-based system. Some a-c institutions would be useful (perhaps even necessary), others fun:
- Private Protection Organizations - there will be a need for rule-enforcement, protection of people, protection of goods, and perhaps even protection of the entire event.
- Arbitrators/Judges - to resolve disputes.
- Courts - and associated legal systems .
- Private Currencies - preferably backed by something.
- Electricity - Might be useful to sell. Can be generated from solar, wind, waves, or gasoline (although negative noise & pollution externalities may be an issue).
- Radar - might be a useful part of national defence. But who pays for it? Perhaps they sell subscriptions to the information for fun, or provide early alerting in case of an incoming flotilla of US Navy vessels.
- Drugstore - No prescription necessary.
- University - talks/classes of interest to attendees could be given, free or for pay.
- Casino - What could be more precious than the freedom to risk money with negative mathematical expectation?
- Mail-order goods - Forget to bring something? No problem! Have a company that finds out when lots of people are leaving and contracts with them to take additional goods, if necessary. If you run out of your favorite brand of toothpaste, their continental agents can buy it and get it to the next people who are leaving, and you'll have it in a few days.
- Floating Green Tortoise - like the Green Tortoise bus which goes to Burning Man so that people can get there without arranging their own transportation. Someone just rents a ship w/ lots of room for passengers and sells berths.

- Other events - This is a little science-fictiony, but one could certainly see Ephemeralisles becoming like a modern carnival or trade gathering. Rather than being a fixed-location yearly event, gatherings could be announced for various locations at various times. People would go to whichever were most convenient, and spend a week or two doing conducting business which is best done away from nations.

Burning Man

Burning Man

Burning Man was part of the inspiration for this idea. Here are some similarities and differences between BM and the Ephemeralisle.

side from the anti-commerce element, its a lot of people expressing their creativity without the normal shackles of government. In the early years they had a drive by shooting range. They shot mortars. The sky is lit up with lasers and flare guns. I floated into the air on a stack of helium balloons. Its fucking amazing!

Seeing what people create at burning man is part of what inspired me to think that a floating ancapistan can actually happen. And would be cool if it did happen. Here you have this enormous artistic effort, in the middle of nowhere, in a harsh environment, happening just because you let people do whatever the fuck they want. Wow!

If people put the amount of time and effort into trying to create ancapistan that they put into making cool shit for burning man, we'd all be having this conversation on a floating platform while we smoked phat joints, fired our guns into the air, and listened to selections from our pirated archive of every song ever made. These people don't sit around and talk, they build cool shit, and lots of it. They build their dreams, instead of whining about how things aren't how they want.

Personally, the art aspect is what bothers me about it. I stayed home last year and worked on the seasteading book while my roommates were there. Because its a festival about fun art, not changing the world, and I think the latter is more important. People's efforts are directed into temporary efforts, which is ultimately less valuable.

When I say "less valuable", I am neither saying "less valuable to me", nor saying that other people must have the same values as me. What I think (I could be wrong) is that, measured by whatever standards or values all the people impacted have, temporary things will generally have less positive impact than permanent ones. Because they don't have as long to make an impact.

I agree that a consequence of art is its impact on observers. But it seems to me that art which is not destroyed after a week will generally impact more observers than art which is destroyed after a week. It will create more ripples. For example, I think community is great - but I find, say, the permanent community of the ABL far more rewarding than the temporary community of BM.

I am *not* saying that burning man is not worthwhile. I think its awesome. I think it has some great influence. But I question whether it gets the most influence for the effort expended. I worry that temporary = inefficient.

I also worry that by having something like that for one week a year, people are satisfied to not change their normal lives. They compartmentalize off their desire to experiment with alternate ways of living and do it as a yearly vacation. Maybe I'm wrong, maybe it inspires them to make changes in the rest of their lives (as it did for me).

Commenter: I think you are making the assumption that people are wasting time and energy on art that would otherwise be spent on changing the world. (I won't get into whether art can change the world.) I think that these are not the same drives. People who

go to burning man may well spend plenty of other time trying to change the world. Perhaps going is instead an inspiration or rejuvenation from how they spend the rest of their lives. You felt you had limited time, so you worked on your book instead of going. But there's no reason why you can't both write your book and go to the festival.

Ephemerisle: Burning Man Part of the inspiration for Ephemerisle is the annual Burning Man festival. Similarities: • annual gathering • harsh conditions • crazy technology • inspiration for the rest of the year However, there are some important differences between the concepts: Burning Man Ephemerisle Focus on free creative expression Focus on free political expression Open-ended, no eventual goal A stepping point on the way to establishing a free nation Rejects money and commerce Enthusiastically embraces money and commerce Expression severely limited by american law (at least, now that its big) Expression limited only by the contracts you choose, the physical world, and the power of your resources and imagination Participants protected by US law enforcement and BM rangers Participants only protected by their own resources and contracts High ticket prices pay for juice to local law enforcement, insurance, rangers, and medical facilities Ain't no one gonna make you pay for nothin' you don't want 'round here.

Implementation

We are tentatively planning to hold the first Ephemerisle July 4th weekend, 2009, off the coast of San Diego / LA.

The tricky thing about implementation is walking the line between decentralized anarchic participation and centralized planning. For example, tying up a bunch of boats together seems unlikely to make for a great festival. It is difficult to tie up boats without docking, moving between them will require a lot of climbing, there is no centralized space - it's not a good foundation. Much better would be to construct a temporary centralized area which includes a marina, and rent space on this "land", berths at the marina, and so forth. A great combination of anarchy and decentralization would be to have standards for interlocking land areas, or even instructions for manufacturing standardized land modules. That way people could bring their own land, and all could be hooked up. The organizers of the event would guarantee a certain base area with some central facilities.

This is a great example of a good spot on the anarchy / planning curve. The organizers come up with a standard land module, and guarantee a certain quantity - but anyone can make / bring their own.

This is, of course, a big project. Fortunately, no one person or institution needs to handle it. Ephemerisle will be implemented by minimizing explicit centralization and maximizing communication between event participants. We won't sell monopolies, but we'll try to provide ways for people to tell whether anyone else will be competing with them. We won't assign jobs, we'll just suggest things that would be nice to have done. Doing a job will often be tied into profiting from it, although doing things for the good of the project is also encouraged.

As an example, consider the question of whether the world of coercive governments will allow such an event to happen. What exactly are the laws of the sea? What agreements cover the use of international waters? These are good questions, and we've found a few web references on the subject. We'd love to see these issues explored in further detail, textual references found, webpages built. But not only do we not want to do this work, we don't want to delegate it either. More accurately, we want to neither do nor delegate the large number of things that are around this level of importance. Hopefully someone else will be

interested. Maybe they'll charge for the resulting document. Maybe they'll give it away. Either way, we avoid the issue.

Methods for communication are the next step. A mailing list/web forum to begin discussion, with initial discussion focused on feasibility, and then on the meta-techniques of how to provide the right framework to let the project grow.

Long-term Effect

Seasteading Future

Could lead to seasteading future even aside from any other method. Independent and parallel. People discover that Ephemeralisles are good places to conduct commerce, let loose, etc. They grow in frequency, length, and size. Eventually, you have one that just never disbands.

Even if the rest of seasteading fails, this would be a pretty cool thing to gift to the world. This thing could be huge, partly because (unlike Burning Man) it would encourage, rather than restrict, commercial activity. One can easily imagine these offshore gatherings starting to happen regularly around the world, where people get together to temporarily escape their oppressive governments, and trade free of regulation. Perhaps centered around existing seastead colonies - but greatly augmenting their size temporarily.

Latest Updates

The above was written as the inspiration for Ephemeralisles, before planning began. This section is reserved for major updates about the actual implementation, to be filled in just before this book goes to press.

(Tentative plan: first Ephemeralisles in San Francisco Bay over July 4th weekend 2009. We are starting in sheltered waters due to the difficulties of creating artificial land and mooring boats to it in open waters)

Chapter 46

How You Can Help

UPDATE: Now that we have founded The Seasteading Institute, go to <http://seasteading.org/> to donate time or money to help make seasteading a reality. In particular, the donations page at <http://www.seasteading.org/donations> and the volunteering page at <http://wiki.seasteading.org/index.php/Volunteering>. The below is somewhat out of date.

We'd like to start by thanking you for your interest. In order to make the tough transition from dream to reality, the seasteading movement needs supporters. People who understand that talk is cheap, that it takes a lot of time, effort, and money to create a new way of living, but still agree that it will ultimately be worthwhile. If you are a realistic visionary like ourselves, hard-headed and open-minded, we'd love to have you participate.

For the project to work, however, we think it's important to expand steadily and gradually. This incrementalism approach is at the core of our philosophy. It's a huge project, and will require labor and money from lots of people to achieve true success, but we think it's important to go step-by-step. Committees don't govern effectively, and effort spread too widely tends to be poorly focused. We want to weld our group of supporters and volunteers into a solid structure, but rushing will only result in a disorganized and vaguely committed crowd. For this reason, we prefer to slowly bring people into well-defined roles.

Here are some of the ways in which we envision people contributing time, money, and professional skills. They are listed in approximate order of when the help will be needed.

- **Paper Review** The current stage of the project consists of performing the fundamental research which will guide our choices later on. Helpful comments, constructive criticism, and pointers to relevant information are all useful. Send us email, or utilize the commenting system.
- **Baystead - Founders** Baystead requires a small group of founders to fund its construction and then live on board. While we can take this role entirely ourselves (and will if necessary), for a number of reasons we'd prefer to share it. The cost will be on the order of \$50K - \$250K per person, most likely about \$100K/p. Unlike normal real estate, there are no seastead mortgages and the market for baysteads is not yet liquid, which means this is more of a financial commitment than buying a house. Interested individuals should be enthusiastic about running their own infrastructure, experimenting with a new lifestyle, and sharing that lifestyle with visitors. They must

also want to live in the SF Bay area. Useful skills, experience with communal living, and a desire to help achieve the larger vision are a plus. We are likely to be somewhat picky in order to make sure incompatibilities don't cause problems.

- **Baystead - Supporters** As a trial version of the seasteed timeshare system, we plan to have a Baystead Supporters program. Basically, Supporters would donate some time or money, and have the right to come stay on Baystead some number of days a year. While we are leery of anything which seems like asking for money or could be construed as being a scam, we have personal acquaintances, at the least, who have expressed interest in such a plan. And since Supporter money is not required for construction, skeptical individuals are welcome to wait until they've seen a built Baystead with their own eyes. { This will be written up in more detail elsewhere and referenced here - P }
- **Baystead - Builders** Just like building a house, there will be a lot of work involved in building baystead. While the superstructure will likely be built professionally, there will be tons of flooring, plastering, piping, painting, etc. We've had several people offer to help with this stage already, and will gladly accept volunteer labor. This will be another way to achieve Baystead Supporter status, as described above.
- **Seasteed Research Team** There are lots of research experiments to be done on various aspects of seasteed life. In fact, we expect this to be the case for pretty much the foreseeable future, even when there are many seasteeds. Unlike the academic world, much of this research should be perfectly doable by ordinary folk. Baystead is a great place for research, by the residents and by visiting Supporters. But research can also be done by interested people anywhere else in the world. We're holding off on creating a research program until we've built Baystead, which we see as a higher priority. (Though if someone else wants to do the work now...)
- **SDC - Founders** When it comes time to found a Seasteed Development Corp., we'll need some business partners / investors / employees. When the time comes, we'll announce what skills we are looking for. We're likely to be very picky, as with any business venture.
- **Seasteed I - Principals** The first sovereign seasteed will need a core group of full-time residents. This group will likely serve multiple roles as residents, employees (doing the jobs needed to keep things running) and investors (since they will own much larger shares than a timeshare residents, and are the most likely people to own multiple shares for rent or later sale).
- **Seasteed I - Timesharers** {We need a cleverer name for part-time residents } While the Principals are the depth of membership, Timesharers are the breadth. This is a vital role, and will likely make up the bulk of seasteed funding, and certainly the largest number of residents. Most people will begin by participating in this manner, because they are interested in someday becoming full-time seasteaders, but are not yet ready to move their whole lives (which we find perfectly reasonable). Seasteading will be driven by demand from customers. The sooner we can get people to sign up, the sooner it will happen. People willing to put down deposits count for much more than those who just express interest. We'll let you know when we're in a position to accept them.

If you are interested in one of these roles, drop us a line and we'll put you on our lists.

Part IX
Misc Topics

Chapter 47

Internet Discussion Groups

There are a number of internet discussion groups on topics related to seasteading. Eventually, if our ideas take root, there may be seastead-specific ones. For now, here are the ones we've seen: { Chime in if you know of others }

- Our organization, The Seasteading Institute, has forums at <http://seasteading.org/forums>
 - Floating-Cities is one of the Reality Sculptors mailing lists. It is based on Patrick Salisbury's paper *Oceana: A Proposal For A New Country* [Salisbury1992].
 - Nation-Builders is a Yahoo group described as *"Dedicated to those seeking to establish new, free nations not tied to existing States. All formulas considered - floating cities, leasing land from existing States, artificial islands and whatever participants come up with. Concentrates on financial, technical, tactical and strategic issues. Complements Libertarian-Nation list, q.v. "*
 - libertarianisland is a Yahoo group created in 10/2003. Its description states *"Space may be the final frontier, but the ocean is the frontier that can be populated now, and for a lot less money. Living in international waters has a few distinctly libertarian advantages. No taxes. No government. No laws, but then, the really nasty people (government, bankers, lawyers, clergy and corporations) will not have an oppressive, thieving, police state government to protect them here. Since the island will be built in international waters there is no limit (other than your resources) to the size of your area. Most of the elements are dissolved in the ocean and can be mined from the brine left after the water molecules are converted to hydrogen and oxygen. "*
 - Transtopia is a Yahoo group devoted to the transtopia island project, which aims to create a community of transhumanists. They consider buying an island, creating one, or using ships. While the main project seems fairly defunct, there is some interesting material in the list archives, and sometimes on the list.

Chapter 48

Intentional Community

For most of our existence, humans have lived in tribes or extended families. This helps make better use of scarce resources such as housing, heating, etc. Only in the past century has the first world achieved the wealth for each nuclear family to have its own dwelling, appliances, and utilities. While there are clearly advantages to this, some people find it unsatisfying to be so isolated. The Co-housing, or Intentional Community movement has developed in response to this. An IC is any group of people deliberately living together, which can mean anything from a college co-op to a commune.

When seasteading, especially towards the beginning, space, utilities, and appliances will be expensive. Hence seasteaders will almost certainly want to use the techniques of communal living. For example, sharing the use of energy-efficient appliances, workshops, boats, a helicopter, an internet connection, and so forth.

Communities are strongest when united by shared ideals, and it seems quite likely that early seasteads will exist largely for ideological reasons. This gives an additional reason why they will be communal in nature. Also, being isolated will increase interdependence among seasteaders. Note that communal does not necessarily mean a communist society where all property is owned jointly. It simply means that the line between what portion of property is public and private will likely be a bit farther than in normal society. People's lives and property will be more intertwined.

This does not necessarily mean loss of control, in fact there are some ways in which it can result in the opposite. One of these public sectors will be the basic infrastructure of the entire platform. In normal living, such utilities are owned by large companies, often monopolies, and it is difficult for one customer to have any control. When a small group of 100 owns the utility, individuals will have much greater say in how it is run.

As they will draw on the green movement for physical technologies, seasteads would be wise to draw on the intentional community movement for communal technologies. These people have useful experience about topics like architectural design - how to lay out common spaces. We would suggest hiring consultants like the CoHousing Company to help with such aspects [CoHoCo].

Chapter 49

The Word Seasteading

While author Wayne Gramlich came up with this name independently, the term seasteading has been used in the US since as early as 1969. In that year it was mentioned in the Stratton report, which led to the creation of NOAA, the National Oceanographic and Atmospheric Agency [Stratton1969]. There was even a magazine briefly published on the topic in the 1970's [Clark2001].

Intriguingly, Seastead is also the americanization of a Swedish name. Bryan Seastead emailed us to say:

Our name Seastead, means "Homestead by the Sea" and is spelled "Sjostedt" in swedish. It is a name I think that is a couple hundred years old given by the swedish military when Swede's suddenly needed last names and my ancestors from Lake Skara, adopted Sjostedt when they went into the service. Then years later, moved to the US to spawn American born "Seastead's".

More recently, a live-aboard boater named Jerome FitzGerald wrote a book called Seasteading: A Life of Hope and Freedom on the Last Viable Frontier.

Chapter 50

Architecture

BLDG Blog, whose topics are Architectural Conjecture, Urban Speculation, and Landscape Futures, had some fascinating thoughts about the profound architectural implications of seasteading:

What interests me here, aside from the architectural challenge of erecting a durable, ocean-going metropolis, is the fact that this act of construction – this act of building something – has constitutional implications. That is, architecture here proactively expands the political bounds of recognized sovereignty; architecture becomes declarative.

The stakes for design have gone up, in other words. It's not just a question of producing better loft apartments, for which you can charge an extra \$300,000, or of perfecting the art of luxury kitchen space; it's a question of designing architecture for extreme conditions and, should your architecture survive, thus opening up room for a new form of what might be called post-terrestrial sovereignty, i.e. governance freed from landed terrain.

Which is not to be confused with advocacy of the project; I just like discussing its political side-effects: architecture becomes wed with, indeed inseparable from, a political project. It is construction in the service of constitutionality (and vice versa).

Wed with oceanic mobility, the architecture of seasteading doesn't just aesthetically augment a natural landscape; it actually encases, or gives physical shape to, a political community. It is architecture as political space in the most literal sense.

Chapter 51

Seasteading Haters

First they ignore you, then they laugh at you, then they fight you, then you win. - Mahatma Gandhi Describing the stages of a winning strategy of nonviolent activism. Probable misattribution: a close variant of the quotation first appears in a 1914 US trade union address

We find it a bit baffling that people would get angry and paranoid about the idea of empowering small groups to try out new political systems. But the way of the world is that change provokes anger, so here is a selection of small-minded quotes to get you riled up. After all, every political movement needs enemies, even a meta-political movement like ours.

Source: Comments on MetaFilter post Once Rapture starts leaking, the old girl's never gonna stop.

I believe I've said it before, but the more I hear about libertarianism the more I am convinced that it is nothing more than pure-selfishness codified as a political doctrine. So let me be the first in this thread to say "Fuck you, you selfish dicks. I hope you sink." posted by Caduceus at 11:40 AM on May 31 [14 favorites]

Part of me wants to see this built. It would be a tremendous waste of resources, but my god, the comedy value:

All these overprivileged libertarians complaining about living in a concrete boat while hordes of stoned drug-addicts and pirates nip at their heels. As the structure falls apart at the seams they're trying to order cruise missiles out of this paranoid terror that some government is going to Shut Them Down.

Cut to: a pair of coast guard officers watching via satellite, facepalming as the whole thing sinks into the ocean. posted by Ndwright at 12:01 PM on May 31 [3 favorites]

Companies that don't want to obey patent laws, meanwhile, can use the platforms to "implement some portion of a patented process on a seastead" to sell cheap goods without paying royalties.

So wait, for property rights or against? You can only choose one else you're a bunch of hypocritical assfaces. In fact, you're probably just assfaces anyway, but at least you can be consistent about your assfacery. posted by Sova at 2:42 PM on May 31 [1 favorite]

They are fascinating, different in so many ways. The only thing I've ever found to be relatively common with experimental societies is rampant child molestation. posted by Brian B. at 5:21 PM on May 31

Source: Floating Utopias: The degraded imagination of the libertarian seasteaders, By CHINA MIEVILLE

Freedom Ship's board of directors are canny enough to recognize tax hatred as a defining characteristic of the tradition of fantasies in which it sits. It is one of countless recent dreams of a tax-free life on the ocean wave: advocates of "seasteading" are disproportionately adherents of "libertarianism," that peculiarly American philosophy of venal petty-bourgeois dissidence.

...

Libertarianism's nemesis, "the state," is no less abstract. This is particularly so for libertarianism's seasteading wing, for whom the political entity "the state" is bizarrely geographically literalized. Their intent is to slip the surly bonds of earth not up but sideways, beyond littoral borders. It is a lunatic syllogism: "I dislike the state: The state is made of land: Therefore I dislike the land." Water is a solvent, dissolving "political" (state) power, leaving only "economics" behind.

...

It is a small *schadenfreude* to know that these dreams will never come true. There are dangerous enemies, and then there are jokes of history. The libertarian seasteaders are a joke. The pitiful, incoherent and cowardly utopia they pine for is a spoilt child's autarky, an imperialism of outsourcing, a very petty fascism played as maritime farce: Pinochet of Penzance.

Source: Amor Mundo: Dispatches from libertopia - going galt

Although these fantasies of self-appointed sooperman sequestration are a recurring libertopian wet-dream, it is apparently an especially alluring notion now that these would-be titans and grifters fear they might actually be taxed and regulated a little in an Obama Administration (if only) thus slowing by a smidge their relentless ongoing (or at any rate pined for) looting and raping of the planet and of the overabundant majority of the people and other beings who share it with them. ... And it's interesting (I can't say it's surprising) to find Peter Thiel right at the heart of this laughable sociopathic libertopian endeavor as well, in addition to his involvement in the laughable sociopathic Singularitarian endeavor.

No doubt he would prefer that his Ayn Raelians "Go Galt" instead in nanobotic treasure caves secreted away in the asteroid belt, but he'll have to settle for now for a li'l patch of libertarian heaven and dysentery and piracy on some crappy abandoned oil rig. Without Big Brother's prying eyes on them every minute of the day, you can be sure that the legion of soopergeniuses in the Robot Cult will be able to code that superintelligent Robot God at last, and the hott sexy slavebots, and the immortalizing shiny robot replacement bodies, and the programmable nanobotic treasure-swarms and all the rest.

Then we'll be sorry for making fun of them! Then we'll be sorry for doubting them! Then we'll be sorry for treading on them! Then we'll be sorry for our regulatory shackling of their genius and our confiscatory taxation of their bounty! Yeah, give it, er, let's see, twenty years, yeah, twenty years from now, and Libertopia will spontaneously order into Robotopia and then they'll transcend into post-humans and, and, and, oh boy, won't we be sorry then!

Fat Lip Leo Weekly: Atlas Shat:

If you require further proof that an alarmingly large number of conservative Americans have yet to advance their collective emotional maturity beyond that of a thirteen-year-old girl, peep this...we applaud these wayward libertards' efforts to play Mayflower and strike a bold new course in Objectivist idiocy, yet wonder if they will recognize the hypocrisy when they accept our foreign aid because nobody will want to gather berries all goddamn day.

Chapter 52

Seasteading In Poetry And Fiction

While it is a new concept, seasteading has made a few appearances already.

52.1 Poem: The City In The Sea

The author writes: I have thought much about a seasteading concept in which the economy of the entire seastead is based on the manufacture of hydrogen, from windmills, wave and stream energy. I picture it as a modern day oil state, except it makes no oil, but it instead hydrogen and sell it to the big markets as fuel, for the benefit of the people who live there and take care of the installations. And as we all agree, it must be in the sea. It will be in the north sea, between Norway and Iceland, where the waves are big, the storms frequent and the streams are strong. And I want it to be a bustling city, that people visit for the design, the art and the nightlife. Just like Reykjavik on Iceland is today.

The city in the sea *By Jens Tandstad*

And so it is reborn
the city in the sea
another sunburned father
throws his shackles to be free

A clean slate for a new life

was towed into alignment the crankshafts dipping slowly but with promise of abridgement

The newcomers, a family
would rent away their base
use only what they needed
to maintain a restful pace

The neighbours came with welcome gifts
and the children said hello and played
They greeted in the shimmer from
the brand new rotor blades

They helped connect the bearings
and then they greased up all the sleeves
the gridded up the newcomers
and heard the first sputter from the leaves

And so another family
arrived upon our shore
they shall not want of nuts and bolts
to build upon their floor

Who were those that came here first
what did they seek to find?
Their gardens, houses, shiny cars
they left it all behind

She was a mother stuck in life
He was one who forgot his wife
Birthdays came, they got it done
partyhat consumption won

The oilprice only soared again
And yet another year in vain
The cost of heat and energy
a shackle, ball and chain

Theres nothing wrong with working hard
but still for some it means
less time for your children
and less time for your dreams

No, our life is not for everyone
most people do not want to run
for some theres life within a box
for some this box is chained wih locks

But let us all remember now
how it all began
before the art of seasteading
before even the plan

A dream it was for centuries
to conquer the high seas
to live aloof at liberty
without laws and decrees

But then fate itself would throw the dice
a man discovered heat and ice

in the compression and release
of cold atlantic breeze

A privy base was what he built
the first, our city hall to be
he named it Leviathan
and released it to the sea

Trailed by ice and shrugged by waves
It lay there, breathing, in the sun
with the humming windflow and whittle of steam
its breath was hydrogen and dreams

And suddenly, a flock of men
concerned with wealth and size
commissioned a great enterprise
to replenish dwindling gas-supplies

And our founder soon, was left behind
by shortsighted business minds
But he remained, in secrecy
maintaining plans for liberty

Whilst tanker ships arrived each day
Fate itself jumped ship to stay
Custodian to citizen!
Employee to free!

Revolution in the steamworks!
Independence, liberty!
Suddenly the shore was no more
assets of a company!

Listen! Hear our island sing
this is how we quench the thirst
the whistle of steam and and the crackle of ice
and in the midst our children plays

We make steam from ice cold water
And fresh water from the breeze
We take water, make it burn
How the rules are twist- and turned

The pistons, rattled by the waves
the windmills, turning in the wind
the ice were leaving in our wake
the steam we make for our own sake

And we shall keep an open shore
to those that want our gift
the ticket is a privy base
enthusiasm and thrift

And we shall open up our homes
to all that come to see
they will remain at liberty
with us here in the sea

For we shall build a city
for those who dare be free
from multitude, with courage
to liberty are we

Yes, we shall build a city
unlike anything on earth
and twenty thousand artists
shall supply us with rebirth

Part X

Further Questions

There are two components to this FAQ. First, we include a copy of the FAQ from our website, which contains short answers to the most common questions. Second, we expand this FAQ with additional detail in the answers, and questions that are less common but still important. We often refer to the book, which contains the most detailed information about our proposals. If you'd like a more general introduction to what the heck seasteading and The Seasteading Institute are about, see *A Brief Introduction to The Seasteading Institute*.

Most sections originated from email responses to questions. If you have additional questions, feel free to email them to info@seasteading.org.

Chapter 53

Web FAQ

This is a copy of our website FAQ, which can be found at <http://seasteading.org/learn-more/faq>.

(Insert website faq here)

Chapter 54

Book FAQ Intro

Next we'll expand the short FAQ from our website with longer answers and more questions.

Chapter 55

General Questions

55.1 I want to seastead! How can I prepare? (expanded)

This is a great question, although somewhat hard to answer because it is unclear exactly how seasteading development will proceed. However, we can provide some general advice:

- **Definitely useful**

- Save money. It is going to be difficult to get a loan to build something as novel and unproven as a seastead, which means we'll need to pay up front for our real estate. And while it would be nice if someone rich built a huge seastead and rented out rooms, it is much more likely that the starting founders will have to scrape to provide their own space, and won't be able to afford much extra. This has the extra advantage that if you don't end up going the seasteading route, your nest egg will still be useful. Money is freedom (but don't enslave yourself to get it!).
- Be active in the seasteading community, which is rapidly growing. This includes: joining TSI's membership program, volunteering at TSI, providing feedback on our ideas, reading TSI blogs, spreading the word about the idea/site/book to people who might be interested. As the movement grows, this will include meetup groups in various areas and even festivals on the high seas (Ephemerisle). Evangelism is definitely important - getting people excited and inspired to hear more about the idea and perhaps someday participate. This is a grassroots movement - it's up to you to spread the word!
- Develop methods for generating income onboard by providing local or exportable value. Examples of local value would be food production, mechanical expertise, massage, or entrepreneurship experience and ideas for seastead businesses. Exportable value might be marine research (and ability to score grants), coaching or therapy by phone, or telecommuting work like freelance programming or web design. One of the toughest things about any small economy is finding ways to make money, and being able to work online seems like the most general solution.
- Move to the San Francisco Bay Area, or another Seastead Outpost. Physical presence will be useful in helping to build and test prototypes, and several of our favorite models for incremental seastead development ([link to making it happen](#)) require a group of founders all in the same coastal city. The listed cities are

currently the most likely candidates for an initial seastead. While we certainly wouldn't want anyone to move on the sole hope of being part of seasteading, it seems quite likely that the movement will kick off in one of these areas, and so it's one factor to consider if you happen to be moving. And these are great places to live, so even if seasteading doesn't work out, there are other benefits.

- Found businesses in our space. Any business based on jurisdictional arbitrage on the ocean (cruise ship medical tourism), or making use of the ocean's resources (offshore aquaculture) that improves the ocean economy will be very useful for seasteading in the long-run.

- **Probably useful**

- Gain experience with communal living, for example by living in an Intentional Community or CoHousing development. While seasteading may attract rugged individualists, a project this big will need to be a team effort. Living in a community can sometimes be challenging and requires excellent interpersonal skills. Strong communication abilities, experience with group facilitation, group processes, and conflict resolution skills like NVC will all be quite useful. And these skills will serve you well in a wide variety of other circumstances as well (management roles, relationships...)
- Expatriate. The ultimate goal of seasteading is to have living space in sovereign - or at least non-US - territory. You can learn to adapt your life and take advantage of non-resident status today by moving to Costa Rica, Panama City, Singapore, or other expatriate-friendly jurisdictions. The low tax rate and low cost of living may also help you to accumulate savings.

- **May be useful**

- Develop self-sufficiency skills, such as first aid, gardening, and appliance repair.
- Develop very seastead-specific skills like ferrocement building or marine law. The risk in doing these is that the seasteading approach may change, or other more experienced professionals in these fields may get involved. While it would certainly be great if people with these skills helped out, keep in mind that experts can always be hired.

55.2 Why did you choose to patent your seastead designs?

The patent that we filed for the Clubstead design - along with any patents we will file going forward - are intended as defensive patents only. It's not our goal to use patents to prevent others from building seasteads based on our designs, or to extort money from those who wish to. We intend to make our patented material available freely (or for a nominal fee if this better suits the legal and business requirements of the organizations who wish to make use of the patents), and our maintenance of patents is intended to protect the seasteading community as a whole.

We are investigating other possible methods for maintaining the availability and protection of the patented material that we produce. We may make use of something like the Open Invention Network, which holds patents for Linux software and allows free usage to anyone who agrees not to assert their patents against the Linux system. Offering our patented

inventions to anyone who agrees not to assert their patents against seasteading companies or individuals would help to promote collaboration among seasteading businesses, which we believe will benefit the seasteading community long term.

We are also researching defensive publishing, which allows us to protect against patents being filed, without patenting our work. The patent system is bureaucratic and complex, with an extremely high barrier to entry for small businesses and individuals. We hope to find an alternative to traditional patents that we can share with the seasteading community at large, making it easier for DIYers and new seasteading ventures to protect their work.

For the time being we will make use of the patent system to safeguard the work that TSI produces while we research other methods. Our primary goal is not to collect intellectual property, but to make sure that seasteading inventions are protected for the seasteading community at large.

(Thanks to volunteer Chuck Grimmett for this section)

Chapter 56

Concerns

People often seem quick to tell us why our ideas won't work, which is very helpful of them. However, we'd prefer not to keep hearing the same reasons, so here are some of the common objections that we have already considered.

56.1 Why is it so expensive?

Some of our reasons for being pleased with the cost estimates from our initial spar platform design, which can be found on the engineering page:

- The ocean is a brutal environment - this is why ships have been described as "A hole in the water you pour money into". And we are not just creating ships or buildings, we are creating **real estate**, so we want it to last.
- This is the first-generation. Just like with any other product, earlier runs are more expensive since they must be built by hand and don't get economies of scale. Eventually, as volume increases, costs come down, and more people can participate. Seasteads are no different. The early adopters help pay the research costs.
- The costs that we are talking about (say \$200 - \$400 / ft2 final cost to residents) are not out of line with first world house prices in metropolitan. It's not as cheap as Costa Rica, but it isn't as expensive as Silicon Valley either. If these estimates are right, we can build brand-new sovereign territory for a cost similar to the housing of many upper-class Americans. To us, this seems incredibly encouraging!
 - Although, note that the cost to residents will be higher than a house of the same price, because seasteads can't be built with low-interest bank mortgages like houses. But this stems from the unique nature of the project and will be impossible to avoid until seasteading is more firmly established.

It is certainly true that you could build some kind of platform, like Rich Sowa's plastic bottle island, on a shoestring, but it is unlikely to serve as the base for a new way of life. (It's already been destroyed once by a hurricane). If you disagree, you are of course welcome to take whatever approach you'd like, and we'd love to see what happens.

Some of our favored options for reducing the price:

- For those looking to start more cheaply, BoatSteading is a viable option.
- In the long run, we think that breakwaters will bring the prices down enormously.
- Choosing the equatorial doldrums means less waves and less cost (also less access to first world customers). Alternately, a sea like the Mediterranean or Baltic may offer low waves (thus low cost) and access to multiple first-world jurisdictions.

We are not ignoring those with less money, and we believe that in the long-run, they will benefit from seasteading also. But it takes cash to start the ball rolling.

56.2 Why do you think you can get freedom without interference? States will never let you be free!

Variations on this theme are quite common from libertarians who are sympathetic with our goals but pessimistic about our chances. For example, Rex Rhino comments on Marginal Revolution:

Who wants to make a bet that the same die-hard peaceniks (not that there is any problem with being a peacenik in and of itself) who condemn say military action in Afghanistan despite the U.S. being attacked, will suddenly call for military action the second someone sets up some sort of tax-haven free-market seasteading community?

Don't get me wrong, I think seasteading is great. But the second it becomes viable, expect to be militarily annihilated with almost universal popular support. All you need to get the right wing in line is some fear mongering about drugs and terrorists, and all you need to get the left wing in line is fear mongering about tax revenue for the welfare state.

If the left and right wing agree to attack you, you are so so dead. Seasteading is a nice idea, but unless you have some sort of super weapon, or you can go under the sea where conventional military can't attack you, you will be lucky to survive.

We are certainly worried about interference. We believe, however, that only by holding up unrealistic goals can one prove that this project is doomed to failure. So here is our favorite response:

We are not seeking a perfect libertarian paradise where we can do whatever we want without any interference. We are simply looking for a significant improvement. To see how large a gain this might be, look at current states and consider the union of available freedoms.

For example, there are countries in Europe (Switzerland, The Netherlands) with fairly lax drug laws (social freedom). There are tax havens (Luxembourg, Bahamas) with very low tax rates (economic freedom). Unfortunately, the drug-tolerant countries tend to be left-wing and have high taxes, while tax havens are more right-wing, socially conservative, and generally tiny countries. As libertarians, we feel that the combination of these two types of freedoms is worth striving for, **even if both are restricted to the levels currently being tolerated by the powers-that-be**. Such a state would be more libertarian than any currently in existence, without pushing the legal envelope.

And in practice, we think we can get even more freedom than this. Countries really do have a great deal of leeway in their internal affairs, after all. A libertarian seastead

nation should easily be able to have no zoning laws or building codes, low or no taxes, no import/export tariffs, few restrictions on weapons, local consumption of marijuana, no minimum wage, no legislated work week, no coerced welfare system, no eminent domain and many other items from the laundry list of libertarian demands.

Sure, there are some definite limitations. Actions that are seen as a serious threat to the security or sovereignty of a nation are likely to bring military force. Some examples are:

- Letting terrorists launder money
- Producing drugs which are exported to countries where they are illegal.
- Researching or building WMD, particularly nuclear capabilities.

But so what? Libertopia is not an option, and we'll take what we can get. We don't think the list of proscribed activities is actually very long, and a seastead which cooperates with existing nations in trying to stop these activities still seems to us like a pretty great place to be.

We know we say this a lot, but it's worth also keeping in mind that there is no one way to do seasteading. Every group is welcome to try different rules. Some of those rules will annoy existing countries enough that they'll do something about it. Others will not. There may be severe consequences to individuals, which is unfortunate, but the system as a whole will learn from its mistakes and move on. So while it is worth discussing how much freedom we can reasonably expect to get, it's not like we all have to make the same choices about how much risk of interference to run, or like the whole movement will live or die based on whether anyone ever gets invaded. This is a decentralized movement, which makes it robust.

56.3 Who is going to move to the middle of nowhere?

We think this is a great question, and we've often asked it ourselves. The keys to our answer are timesharing and incrementalism

Incrementalism is an answer because we never need to find 10,000 people willing to take the plunge. We only need to find the core of enthusiasts to start, say 10 people. Then the 40 people who are willing to move now that there are 10 people. Then the 100 that will move because there are 40, and so on. It's not that there is no one willing to be the first, just that there aren't very many. But that's ok because we don't need very many to bootstrap.

Having many residents be timesharers or hotel guests, by letting people participate part-time, is crucial as well. Rather than moving to this floating platform, people can just visit, which many more will be willing to do, as there is a gargantuan difference in the level of commitment. This is especially valuable in converting the skeptics and realists, who will have reasonable doubts about such an ambitious venture. While there are 52 weeks in a year, our anecdotal surveys suggest that the ratio of people willing to do a new country full-time vs. 1 week a year is at least 1,000:1, possibly much higher. Hence many initial residents will either be guests or support staff.

One version of the question points out the importance of network effects as a threat to the incremental approach. (A network effect is when something is valuable based on the number of interconnections, which go up as the square of the number of participants). While network effects can be important, if they were truly incompatible with incrementalism, there would be no networks that started small. Yet almost all networks (big cities, land and cell-phone networks, websites like Google and eBay) that are cited as examples of the importance of network effects started small, growing from a tiny seed one piece at a time. The big,

successful networks have **both** incremental properties, which allowed them to grow, **and** network properties, which make them more and more useful as they grow.

So, sure, a new society will have network effects, which will make it hard to grow at the beginning. Just like any new venture. Which is why, like any new venture, it will need to start out appealing to niche markets that are currently under-served. The application of this principle to sovereign floating cities seems rather straightforward.

56.4 Why would anyone vacation on a seasteed instead of a resort?

Some reader comments:

"What would make this seasteed more attractive to potential investors/buyers/renters than a beautiful piece of pristine oceanfront property in a cheap Caribbean paradise"

"this project will have to compete in the marketplace. And since there are lots of pristine paradises left in the world at cheap prices, why would one choose a flimsy little artificial floating platform...with dubious politico-legal status, if one can have a romantic piece of paradise with real solid ground under one's feet. "
What will people do on a seasteed?

Seasteeds and islands have different kinds of romance, and will appeal to different people. As long as we can find enough people who think seasteeds are romantic, it doesn't matter if many prefer islands. Niche markets are not necessarily a bad thing for a business, if they aren't served well by other options, and they are big enough niches.

Some reasons people might find a seasteed vacation attractive:

- The unique legal status of a seasteed, which will let a seasteed have some unique attractions onboard.
- To experience an experiment with an alternative social system.
- The "wow" factor, which the Freedom Ship is appealing to. Seasteeds aren't quite as wowie as a mile-long ship, but they can make up for it by actually getting built.

In general, the answer is to leverage the uniqueness of seasteeds. And if that only appeals to a tiny fraction of the world, that's still plenty to start with. (Note, for example, that Burning Man is remote and uncomfortable, yet has all three of these characteristics).

Also keep in mind that this question ignores [Dynamic Geography][], our central thesis about why societies on the ocean will work better than those on land. Sure, oceanfront property in the third world is cheaper and prettier, but there is a reason that most people who can afford to live in the first world instead. Political and social institutions matter. If we can provide an innovative society that efficiently provides government services, we believe that productive people will flock to it as a place to live and work - and save those Caribbean "paradises" for vacation.

As for what people will do onboard, our first response is "the same things anyone else does", but perhaps we don't get out much. As long as there's an internet connection, it might take us quite awhile to notice that we were on a small, isolated platform.

The simplest answer is to point out other similar lifestyles. For example, vacationers will be able to do pretty much anything they could do on a cruise ship, and they can focus on



the unique activities offered onboard, since anything else they need to do can be done at home. Resort employee on a seasteed will find it much like working on a cruise ship.

In terms of permanent residents, it will be more like the many people who live in isolated, rural areas, or to the live-aboard boaters. While such a life does not appeal to everyone, those who like it rarely seem to be bored. And permanent residents can always take a vacation elsewhere if they need to be surrounded by masses of people. Note that the closer a seasteed is to land, the more it becomes possible to just go to a major city for the day or the weekend. This makes seasteading even more like just living in the outback, and is one of many reasons a CoastStead seems like a good place to start.

56.5 Pirates will get you!

Piracy is still a problem on the high seas, but does not seem particularly worrisome for a seasteed. It seems to mainly consist of two types.

Much piracy is small-scale theft - for example, of the 335 attacks reported in 2001, only 73 involved guns. 16 ships were hijacked, and 21 people killed (all but one in asian waters) [ICC2001]. A sea-city will be much too large for this kind of criminal. Even an individual seasteed - a concrete tower - will be a much tougher target than a luxury yacht. This type of piracy is mainly notable for being vivid and exciting - it is rare enough that oceans are still full of private pleasure craft. Still, we recommend that small seasteeds avoid the few pirate hotspots (Southeast Asia and Somalia).

Some piracy is done by large organized groups who capture entire ships and their goods (often tens of millions of dollars worth) to be fenced. They use forged documents to obtain a new load of cargo from legitimate shippers, and then steal it too. It is worth noting that these groups specifically target container ships, not cruise ships, which is not at all surprising. After all, a container ship has only a few crew and vast amounts of cargo, nicely boxed and ready to be fenced. A cruise ship has far less saleable stuff, and far more people to deal with. In fact, we wouldn't be surprised if there was 100 times the "crew per \$ of movable cargo" for a cruise ship vs. a container ship, so it's no wonder that thieves focus on the latter! The cost/benefit analysis just doesn't work out for this kind of crime:

- Seasteeds would stand out in port, so they can't be sold or used to obtain new cargo.

- Seasteaders will be defending their homes, not their employer's trade goods, so they'll fight harder.
- Crew / \$ of cargo: Since seasteads are residential, they are much more like the cruise ship than the container ship. This means far more danger for the criminals, and far less profit.
- The seastead shape makes it very defensible against small arms - it's like a concrete castle. (Against weapons large enough to destroy the spar, it's more vulnerable, but now we're talking about navies, not pirates).

In other words, why attack a platform of people who would be defending their homes when you could attack a cargo boat with a few lightly armed sailors who would much rather not die to protect some corporation's cargo?

One response to this is to worry about ransom. Well, there are plenty of high-end cruise ships with multimillionaires on board, and we've never heard about one being hijacked for ransom. Just like us, these cruise ships use low-tax, low-regulation flags, so it isn't like they have special protection.

As of 2008, Somalian pirates have been in the news quite a bit, most recently capturing an oil tanker. This does not change our analysis in the slightest. An oil tanker has few crew and an incredibly valuable, easy to fence cargo. This is very different from a seastead. Furthermore, the Somalian pirates have small boats and operate out of Somalia as a base - in a CNN article they brag about operating as far as 80 miles from Somalia. It turns out, amazingly, that very little of the ocean is within 80 miles of Somalia. As long as seasteads avoid Somalia and mount some small arms, we have nothing to worry about from pirates.

If you'd like to see data, I encourage you to check out [A map of 2008 pirate attacks](#). You can click through to the details, and notice that, for example, most occur while anchored and involve no weapons (ie robbers sneak onto the ship to steal things). These banal attacks are the equivalent of someone stealing your car stereo - not pleasant, but not the sort of life-threatening horror that would render the seas uninhabitable. Also notice the complete lack of pirates in the North Atlantic and North Pacific.

The armed and organized groups which seasteads should be the most worried about are the navies of traditional governments, as you can see in the [Politics](#) section. Seastead defense is discussed in the [infrastructure](#) section. If you compare the size, scope, and sophistication of pirates to that of government navies, it's just ludicrous. Like a guy selling watches on a street corner vs. Microsoft!

Chapter 57

Alternative Strategies

There are a number of questions that boil down to "Why do you recommend this particular structure or strategy":

57.1 Why not just buy a boat?

This is a good question, and there are certainly some advantages to the boat approach:

- It makes fitting into international law easier.
- Boats are optimized for movement (low drag), so a boatstead could move rapidly and often (touring the world each year, for example).
- Starting out would be easy, because you'd just buy a boat, rather than having to design a whole new type of structure. And people can join you just by buying additional boats of their own.
- There are a wide variety already available, new and used, as well as repair services, an existing pool of boat owners, parts, add-ons...
- Cruise ships demonstrate that boats can be big enough to be floating villages - the largest carry thousands of people.

However, there are substantial disadvantages to using boats rather than platforms as well.

- **Purpose.** The two structures are designed for different purposes. Boats are made to travel from place to place through the ocean, while seasteads are designed to live in. Seasteads will thus be much slower, but also much roomier, like the difference between a house and a car. Sure you can live in an RV - but it's just not as comfortable as a house. The "house-like-ness" of a boat ranges from a car up to that of a (really nice) RV, while we believe seasteads will range from an RV up to a normal building (with an ocean view).
- **Wave coupling.** Boats are coupled to the waves. This makes them vulnerable to storms and somewhat uncomfortable when there are significant waves. Spar seasteads are mostly uncoupled from the waves, so they don't bob or rock. This is a nice feature for a permanent residence. Boats must be very large to not move, and our incremental approach dictates starting small. Also, if there are any waves, this coupling makes

it very difficult to attach multiple boats into a large community (even with spar seasteads, it's still not easy).

- **Solar area and living volume.** it's very important to have enough solar area per person (for growing things, solar power, passive solar, and just to have some outdoor space). While you can grow some food on a boat (see Neumeyer1982), it's still problematic. It's also good to have a reasonable amount of volume, for comfort, working room, storage, etc. Boats don't maximize for deck space, and only huge tankers maximize for volume. Since the purpose of a boat is to travel quickly, they tend to be very cramped to live in. One way to think of it is that people are willing to accept much less space in places they visit (hotel rooms) than in places they live (apartments, houses). If ocean living is cramped, that will discourage permanent residence. Large boat designs, such as the Freedom Ship, mostly consist of interior units which don't get any direct sunlight. That is just not an attractive place to live.
- **Cost.** Boats are cheaper than spar platforms. Our first spar platform seastead design is \$260 / ft² (interior area), \$600/ft² (solar area), including infrastructure. Some brief research suggested that used cargo ships cost somewhere around \$100/ft² of deck space. So boats offer a substantial cost savings. However, the spar platform design is for a luxury hotel, whereas the used cargo ship would need substantial retrofitting, so these numbers aren't quite comparable. More detailed comparisons will be forthcoming.
- **Infrastructure.** Boats are not built for long-term living, and so must be retrofitted. This means the infrastructure is likely to be more expensive, or not work as well, because it was not part of the design from the beginning. The design and use of a seastead are in alignment.
- **Marketing/publicity.** it's important that this seem like "a new way of life", and that seasteads look neat. People are more likely to be interested in them and magazines to write articles about them if they look cool and different. This may also come into play in determining the legal status of seasteads.
 - *Modularity* * While it may be possible to lash together a number of boats into something like The Raft from Snow Crash, such an agglomeration may not deal well with storms. Travel between boats of different sizes and sharing infrastructure will also be difficult. Seasteads will be designed to be assembled into large, well-connected cities. This point is one of the most important - a boat works pretty well in the short-run, but it just doesn't scale. The vibrant economy of a city comes from the tight network of personal and business relationships enabled by geographic closeness. A bunch of separate ships are more like nomad tribes who trade with each other - you just won't get the integration and network effects that make a city such a great place to be.

Weighing these factors, we think a platform is a better approach if your goal is to create permanent ocean settlements. However, boatsteading is a pretty reasonable strategy as well. It may even be better in the short-term, but we think it is much less likely to transform the world.

57.2 Why not just buy an island or part of a third-world country?

First, many people don't realize that there is no such thing as an "unclaimed" island. Even if an island is unoccupied, it extends the owning country's EEZ, including fishing and mineral rights, which are always of potential value. So even small, barren, remote rocks are claimed by existing countries, and buying an island does not get you sovereignty - that is an entirely separate matter. Still, some find this approach more natural. For example, one reader wrote in an email:

"For the investment required to build 100 acres of floating condo, you could take over three Third World hellholes, complete with workforce and low-quality army."

We see a number of major disadvantages with this approach.

First, countries have in practice been very reluctant to make deals for sovereignty. For whatever reason, it just doesn't happen. Strauss gives some of the reasons:

There are reasons for existing countries to be reluctant to sell sovereignty over pieces of their territories. The closest thing to sale of sovereignty that is conducted routinely is the sale of corporation charters and ship registrations...but any number of those can be sold without reducing the size of the country doing the selling. In addition, such sales produce revenue year after year, in the form of renewal fees. And in the case of emergency (e.g. embarrassing activities by the buyer), the seller can decline to renew the charter of registration. But there is only so much land a nation has to which to sell sovereignty...and once it's sold, there is no further income to be had.

There is also the great-power factor...These great powers tend to want to see the status quo maintained...the fewer the players there are in the international game, the easier it is for the great powers to manage things to their own advantage. A country selling sovereignty would face being cut off from the aid, trade, etc. that the great powers can offer. Thus they are only interested in doing such things if there's a large, ongoing profit to be realized...The small countries really aren't interested in taking the grief that would be involved in selling sovereignty just for a few, one-shot payments from buyers. Strauss 1984, pp. 12-13

Note that free trade zones which allow economic freedom but not political have been very successful, and countries seem quite willing to allow them. But we should not confuse these with new country prospects: they are temporary and the host country maintains political control. We have not seen free trade zones develop and then secede, but rather the opposite - after developing for a number of years, free trade zones like Hong Kong get reincorporated into the parent country. In fact, this "Build - Operate - Transfer" model, where "Transfer" is back to the host country, is a standard model for economic zone partnerships. And I shudder to imagine the reaction of China, India, or an African government to a rumor that one of its "Special Economic Zones" had a secessionist movement.

While we don't have the geopolitical expertise to evaluate his claims, there are several other reasons why we find seasteading more appealing:

- **Scope** If we can make seasteading work, we can transform 70% of the Earth's surface into a laboratory for experimenting with alternative social systems. If we buy an island or part of a third-world, all we would have would be one piece of dirt. While we

believe that having more sovereign pieces of dirt is a good thing, our vision is much bigger than that of just creating a single new country.

- **Psychology.** Humans are territorial creatures, and all land is claimed territory. Look at the history of violence in border disputes, lasting for hundreds, sometimes even thousands of years, because two different tribes have an attachment to the same piece of land. Even with an agreement from the government, the citizens may consider the land to be rightfully theirs. This is why we find it much more attractive to start on the frontier, the blank canvas, rather than creating a new territorial feud.
- **Scale.** Land doesn't easily scale, and so doesn't fit our incremental approach. It's pretty clear how to build the first percent of a 100 acre floating condo - you build a 1 acre floating condo. But how do you take over 1/20th of a third world country?
- **Blood.** It only takes cash and sweat to start seasteading, and maybe a little danger of drowning. If you start trying to take over a country by force, there is a much serious risk to your life. Besides the inherent disadvantage, consider the selection effect on what type of countrymen you will have - less entrepreneurs, and more people who like to solve problems with violence.
- **Staying Bought.** An honest politician is one who stays bought, but they can be hard to find. And of course, the people in a government are always changing. Any deal with a country for a piece of its territory can be rescinded by a new administration or a new party coming to power. The nicer the infrastructure you have developed, the more attractive a target you will appear.
- **Dynamic Geography.** This idea is key to making new societies an improvement over the old. And it doesn't work on land. Floating cities are not just taking advantage of an underutilized part of the world, they result in a shift in incentives which will push power towards the people. A new society on land is likely to suffer the same ills as current ones.
- **How?** We can see the path to sovereignty via floating platforms. We haven't the slightest clue how to take over a country. Even a very small one.
- **Revolution.** If 100 people build and live on a seastead, they only have to worry about external threats. If 100 people take over a 10,000 person 3rd world country, they must always worry that the displaced locals will grow restless and revolt (probably with international sympathy).

So while it's theoretically possible that a country could be persuaded to sell sovereign title to some of its land, to us this path appears difficult, uncertain, inflexible, and extremely expensive, and in the end it results in less. Hence it does not seem like a good way to proceed.

However, we don't want to overstate the case. Land has a big advantage, which is that it is much cheaper and easier to build on, with far fewer engineering challenges. It also has a clearer place in international law (although this is a mixed blessing). Also, many of our concerns are based on our expectation that opportunities for purchasing sovereignty will be poor, based on past history. If a good opportunity was found, where there was reason to believe that the deal would last, that it would not result in a territorial feud, and the price was good, it would certainly be worth exploring. Such an opportunity would most likely be

geographically isolated and uninhabited - a distant island, for example - to minimize the risks of later revolution or renegeing on the deal.

There is actually some synergy between the two approaches, because seasteading would allow a new land-based country to franchise its sovereignty, through the ship flagging system, or through contracts for floating cities within its 200 mile EEZ. Thus seasteads would benefit from having a sovereign territorial ally, while being able to provide some revenue in return.

57.3 Why not a used or abandoned oil rig?

While there have been successful social movements born from squatting (Christiania comes quickly to mind), we find efforts that don't include legal title unattractive for many of the reasons in the FAQ entry "Why not just hide?" Rightful owners, or the coastal state, may re-assert their rights - especially if the squatting is successful.

At least one nonprofit, the Gulf Coast Preservation Society ([link](#)), has a donated oil rig. The donor gets both tax writeoffs and the savings of not having to pay for decommissioning. A used or donated oil rig, if the structure is in safe condition, might be a good place to conduct scientific research. There are some disadvantages, however.

Artificial islands and installations such as oil rigs are all in EEZs, where they are under the legal jurisdiction of the coastal state. So there is no political freedom to be had there. And much of the scientific work we'd like to do is explicitly regulated within the EEZ, such as marine research, energy generation, and aquaculture, so would require permits from the coastal state.

That said, if someone were to offer a convenient oil rig, we could probably find a way to make use of it!

57.4 Why should libertarians follow this approach?

Since your authors are libertarians, and expect many of their readers to be, we have thought long and hard about how this strategy compares with other ideas for making the world more free.

Nation-wide Democratic Reform

First, let us stop laughing and catch our breath. Consider recent history. Ron Paul was (by libertarian standards), a smashingly successful candidate in the Republican primary. Yet he never had the slightest chance of winning the nomination - his strong showing got him 1.6% of delegates and zero states. There are a lot of reasons for this, but these two should suffice:

1. A libertarian running for president is trying to get something of enormous value in order to not use it. This means that he will have far less support from concentrated interests, because unlike a normal candidate he can't borrow on his future expectations of power. Sure, he may appeal to dispersed interests, but concentrated interests have much more to gain from a candidate's support and so can give more. (Quote Jonathan's Catallarchy piece on the subject)
2. Most people are not libertarians.

An analysis of nation-wide democratic reform will quickly demonstrate that this strategy is in many ways opposite to our own. It:

- Is very non-incremental (even a small country like NZ is much bigger than a fully-functioning sea-city would be).
- Requires huge resources, which are wasted on advertising (a one-off) instead of turned into permanent infrastructure (which generates continuous benefits).
- Involves converting others rather than serving as an example.
- Only results in transforming one existing political unit, rather than creating a system for innovation in politics.

The benefit to this strategy is of course that people don't have to move anywhere, but the benefit is worthless if it can't succeed. And the reluctance to move is exactly why this route is hopeless, since current governments are exploiting their trapped populace. We think that getting out of that trap is the key to avoiding exploitation, and so we believe that any efforts to reform large existing countries are a hopeless waste of resources.

We frankly admit that this sucks - we love living in California, and would much rather freedom came to us. But as libertarians are fond of pointing out about other people's utopian dreams, wishing does not make it so. Specifically, it will not make a system act differently than its nature and the incentives it provides to the people who participate in it. And just as this dictates that centrally managed economies will be slow and lack innovation, it dictates that modern democracies will have highly parasitic governments, because we are too rich for it to be worth fighting and too tied to our homes to run away.

To get a libertarian society, we must change these systemic incentives, and we think seasteading is the best way to do that. If you have a better idea, we'd love to hear it.

Free State Project

The Free State Project is "A new strategy for Liberty in our Lifetime":

The Free State Project is an effort to recruit 20,000 liberty-loving people to move to New Hampshire. We are looking for neighborly, productive, tolerant folks from all walks of life, of all ages, creeds, and colors who agree to the political philosophy expressed in our Statement of Intent, that government exists at most to protect people's rights, and should neither provide for people nor punish them for activities that interfere with no one else.

When you sign our Statement of Intent, you signal your commitment to move to the chosen free state, New Hampshire, within five years of obtaining 19,999 other people who commit to move. The more signatures we get, the more secure people can be in their decision to move, because they know that many other people will also be moving- enough to make a real difference! You don't have to wait until we have 20,000 signatures to move, of course, but that option is there to let you be more secure in your decision.

The FSP is the brainchild of Jason Sorens, a Yale PhD student whose thesis was on the political economy of secession. He describes the motivation in an interview:

At the time, around 2001, there was a great deal of discussion among libertarians about the failure of libertarian electoral and political strategies up to that point. The libertarian movement had been active for at least three decades, but with only a few policy successes to show for it.

Many people were considering new strategies to increase the weight of libertarian ideas in the policy debate. And the Free State Project seemed to me to be an appropriate way of concentrating activist resources into a single geographical area where they could have a much greater impact.

Another factor that caused this idea to occur to me was my own research on autonomous movements around the world. The fact that the regional or state level is becoming more important worldwide seemed to indicate that the same trend may happen in the U.S. - that the state level may be the level at which important political action takes place in the future.

...

Well, the federal government - including stray libertarians operating within it - is very far removed from American citizens. I think it's highly unlikely that libertarians could ever control congress, the presidency, and the federal judiciary. It's much more likely that a libertarian state could emerge.

Simply at the state and local level, many reforms can be accomplished - everything from privatization of education, to deregulation of utilities, to ending abuses of eminent domain and asset forfeiture.

But even further than that, we can begin to rein in federal power by using the state to challenge the federal government's authority in many areas, from pursuing tenth amendment lawsuits, to passing state laws that render federal laws somewhat ineffective, to the more extreme possibilities of outright nullification or some kind of unilateral declaration of sovereignty.

The FSP is an attempt to get around some of the problems of the previous approach (nation-wide democratic reform). The key observation, of course, is that in our winner-take-all political system, a libertarian movement that is a few percent everywhere has no power, but by concentrating all those people in one state, the movement can take over the state. We find much to admire in the movement, especially as compared with previous efforts:

- The idea is based on systems-level thinking, not just blind hope. For example, if it really worked, then it would not only change the target state, but also encourage other disempowered minorities to start similar movements. This would turn the 50 states into a laboratory for experimentation and innovation, much like Dynamic Geography. There would be more friction (it's still costly to move between homes, and the barrier to entry to take over a state is much higher than starting a new sea-city), but it's an idea in the right direction.
- By picking an already free state, participants can immediately increase their freedom by moving, so they get some benefit whether or not the project succeeds.
- The participants are willing to move their homes and jobs in order to live in greater congruence with their values, and change the world in a positive direction.

Sadly, we see some serious problems with the FSP:

- Participants are still tied to a single geographic location, thus (according to our theory) vulnerable.
- It targets change to where it is least needed: the local and state level. The problems of government are problems of size and distance between those paying the bills and

those wielding the power. Most of the tax and regulatory burden in the US comes at the federal level. So the places where the FSP can concentrate enough people to make a difference are exactly those that need the least change. We should note that the FSP has some longer-term strategies to address this: by refusing federal funds and asserting state independence they should be able to somewhat decrease federal control. For example, states have in the past temporarily resisted Medicaid and the drinking age of 21 through these methods. And states which allow open containers of alcohol in vehicles are currently doing so in defiance of federal policy at the cost of some federal highway funds. Still, it is unclear whether a substantial assertion of independence would be permitted by the federal government.

- It doesn't seem to be working in practice - as of February 2008, there were 8,221 signups and only 516 local participants. These numbers may make for a good festival, but they fall far short of the number needed to significantly influence NH state politics. (Which bodes poorly for us, and behooves us to plan carefully how we can attract a larger audience).

One of the common FSP counter-arguments to Seasteading is summarized by George Donnelly:

I enjoyed your presentation, but you said something about how you felt uncomfortable with the FSP strategy because it was on land controlled by the strongest military in the world.

But the US Navy controls the seas. So the risk is similar if not greater with seasteading, no? At least with NH, it's contiguous with a huge landmass and we have a reasonable chance of escape, but if the navy puts a missile into a sea city, seasteaders may be left at the mercy of the sharks.

I really liked your concept and your presentation, just playing a little devil's advocate. Thankfully, NH has a seacoast so the two plans are in a sense complementary.

Imagine a belligerent, territorial guy who owns a large number of guns, grenades, and mortars. The mortars can shoot up to 3 miles away, and he claims the land within a mile of his house. Which is safer, taking a dump in the woods 2 miles from his house, or taking a dump in his living room?

Yes, the US can, in theory, attack you anywhere. But they are a zillion times more likely to attack you if you take a dump in their living room!

I don't see how the option of forfeiting all one's non-moveable property and fleeing from the law makes the "shitting in the living room" scenario more attractive. We don't want to run, we don't want to hide, we want to be autonomous and open. If it comes to a fight against the most powerful military in the world, we have lost, no matter what happens afterwards.

Crypto-Anarchy

Here is crypto-anarchy described in Tim May's Crypto Anarchist Manifesto way back in 1988:

A specter is haunting the modern world, the specter of crypto anarchy.

Computer technology is on the verge of providing the ability for individuals and groups to communicate and interact with each other in a totally anonymous manner. Two persons may exchange messages, conduct business, and negotiate electronic contracts without ever knowing the True Name, or legal identity, of the other. Interactions over networks will be untraceable, via extensive re-routing of encrypted packets and tamper-proof boxes which implement cryptographic protocols with nearly perfect assurance against any tampering. Reputations will be of central importance, far more important in dealings than even the credit ratings of today. These developments will alter completely the nature of government regulation, the ability to tax and control economic interactions, the ability to keep information secret, and will even alter the nature of trust and reputation.

While computer technology has developed enormously since this was written, the main impact seems to have been on record industry sales, not on "the ability to tax and control economic interactions". Digital cash has not taken off. People occasionally establish significant anonymous reputations, but they usually seem to get outed eventually.

Despite the enormous possibilities of crypto anarchy, it has been hampered by the fact that the real world remains incredibly important. Even if you earn money virtually, it's hard to evade taxes when most of your money is spent on physical goods. And while technology seems likely to continue chipping away at the physical world, we aren't all going to be jacked into cyberspace full-time anytime soon. We certainly wouldn't discount Tim May's predictions, and over time we expect more of them to come true, but only slowly and for a limited subset of human affairs. For those of us who want true freedom now, this is not a solution.

Market Anarchism

Wikipedia describes this philosophy as:

Anarcho-capitalism (a form of market anarchism or individualist anarchism) is an anti-state political philosophy that attempts to reconcile anarchism with capitalism. It advocates the elimination of the state; the provision of law enforcement, courts, national defense, and all other security services by voluntarily-funded competitors in a free market rather than through compulsory taxation; the complete deregulation of nonintrusive personal and economic activities; and a self-regulated market.

Market anarchism is also known as polycentric law, and it is in many ways a brilliant and elegant idea, so it is difficult to do it justice in such a short space. If you are interested in the design of social systems we recommend David Friedman's book *Machinery of Freedom* as a great introduction (disclaimer: MoF was written by Patri's dad). We think this system has great promise, and would like to use some of its principles on seasteads (implementing government with competing private companies whenever possible).

Some benefits:

- It is based on systems-level thinking: trying to change the incentives facing those who govern so that they'll do a better job.

- Like the FSP's federalism, it is not only system-oriented but meta-system oriented: it is not a specific legal system but a system which will generate efficient legal codes through competition, innovation, and copying. (See Friedman1996)
- While there are no present-day anarcho-capitalistic societies, proponents believe that some past societies can be regarded as operating under this system (or at least it's essentials), most notably saga-period Iceland (Friedman1979). This means that there is some empirical evidence that the system can work.

However, we have two main concerns: incrementalism and stability.

Incrementalism

How do you get to ancap incrementally? One might imagine privatizing one industry at a time, but that can't really be done without government cooperation. You could privatize one area at a time if governments were local, but in the first world most power is concentrated in huge central entities. Central governments around the world have a strong tradition of using their military to suppress any threat, including regional autonomy.

A variant of ancap called Agorism suggests:

Achieving a market anarchist society through advocacy and growth of the underground economy or "black market" - the "counter-economy" as Konkin put it - until such a point that the State's perceived moral authority and outright power have been so thoroughly undermined that revolutionary market anarchist legal and security enterprises are able to arise from underground and ultimately suppress government as a criminal activity (with taxation being treated as theft, war being treated as mass murder, et cetera).

While we are certainly in favor of a flourishing black market, to us their endgame appears laughingly unlikely. It's going to take one helluva black market to be able to suppress the largest military in the world!

Stability

Is ancap stable? Many critics have expressed concern that the private protection agencies will combine to terrorize the populace. And the limited evidence so far is that anarchic societies (medieval England, Iceland) tend to develop centralized states over time, especially when there is an external threat. This should be of no surprise if you buy the arguments advanced earlier that rents attract rent-seekers and wealth attracts stationary bandits. Ancap may be a more efficient system, but it's missing Dynamic Geography's "reset button". While it lasts, it changes incentives for the better, but it doesn't seem to address the incentives which, empirically, seem to consistently lead to large central governments.

Taking over a country

See "Why not just buy an island or part of a third-world country?" (section 57.2)

57.5 Why not just hide?

Some people's instinctive reaction is to question why we need new countries when bad laws can just be dealt with by ignoring them, hiding illegal activities. What would you want to do on a seastead that you can't just do in your own home? There are a number of serious problems with hiding as a solution to bad laws:

- **Integrity.** Imagine asking gays "Why do you need to be accepted by society, when you can just hide your sexual orientation and do whatever you want in the bedroom?" Being able to live one's lifestyle openly and honestly, whatever it may be, is of enormous value to integrity and self-esteem.
- **Scale.** Hiding is a solution that only works at small scales. The bigger and more successful your movement or community, the more likely it is to be noticed and shut down. We are not interested in starting something where success will quickly and inevitably breed failure. We want to change the world, and that means building something way too big to be hidden.
- **Limited scope.** Some activities, by their nature, are easy to hide (drug use). Others are not - opening a hospital. Hiding thus greatly limits what can be done. And hiding works terribly for systems (as opposed to activities) - how do you hide the fact that 1,000 people have agreed to be bound by a new legal system from those trying to enforce the new one? Our main goals, after all, are at the level of systems. We think the world would be enormously better if people had more freedom to create and experiment with alternative political systems, because we think that existing systems are far from optimal and cause a great deal of suffering. Existing systems would be even worse if we couldn't hide from their bad laws - but we dare to dream of a world where we get rid of bad laws instead of hiding from them.
- **Long-term planning.** A life of hiding is a life of uncertainty. One never knows when one will be exposed and suffer consequences for hidden actions. This is personally stressful, and bad for business and investment.
- **Security by obscurity.** Protecting by hiding is simply another version of this rightly-maligned concept from computer security.
- **Capital and Property.** As Hernando De Soto documents in *The Mystery of Capital*, wealth differences between nations can partially be traced to differences in their capital markets. In rich nations, property rights are clear and enforced, business is done out in the open, and so businesses can get loans to expand. In poor nations, most things are done on black markets where property rights are fuzzy, and most capital is informal. This means that small business owners can't get loans, because they can't prove what they own, and investors don't have confidence that the business can continue operating. Restricting yourself to the black market can be quite profitable (consider drug smuggling), but it is also a dangerous life (consider drug smuggling). To really change the world, we need investment, contracts, and property rights, and that means operating in the open.

As you can see, for people with integrity, who think big, want to reform political systems, plan for the long-term, raise investment, and run businesses, hiding is a poor solution.

Chapter 58

Bad Consequences

While we think that seasteading will have an enormously positive impact on the world, there may be some bad consequences. Here are some of the ones that readers have been concerned about:

58.1 Seasteads will enable cults to operate without interference

Seasteads enable all marginalized belief systems to experiment with their own societies. We think the net result of this will be hugely positive, but we do admit that there will be negatives along the way. After all, some belief systems are marginalized because they are harmful. In addition to enabling pacifists to live without paying taxes to support murderous wars, seasteads will enable cults to brainwash their members far from watchful eyes. This may lead to some tragedies. But we see far more pacifists than cultists in the world, and so we believe that seasteads will enable far more people to live their ideal lives than to harm others.

The hidden assumption made in asking this question is that any change to the world must not make anyone worse off (what economists call a Pareto improvement). We don't think this is a very realistic standard to hold new ideas to, and so we are happy to just do net good. That said, accepting that some people will use our ideas to do harm does not mean that we have to help them, and any seastead construction company we start will have ethical standards about who it sells to. For example, see the Universal Human Right, which we think will go a long way towards ensuring that seastead residents are not exploited.

58.2 Seasteads will attack each other

The threat of war is a natural concern. After all, one of the main goals of government is national security, and a variety of small governments definitely poses some challenges in this area.

Seastead vs. State Violence

For example, Dan Tarrant writes in a comment on Marginal Revolution:

One can imagine Seastead Alpha hiring Blackwater to invade upstart Seastead Beta and enslave all their residents. Or a few of the richer members of Seastead Alpha deciding that the "contract" is null and void and all residents are now their personal surfs[sic].

Byrne's reply "*Doesn't this apply to government in general?*" is the first part of the answer. To expand: One can also imagine a small group of people taking control of a country, expropriating much of the income of its residents, concentrating military power into one army, forbidding its citizens to wield weapons, and greatly limiting their freedom. Except one doesn't have to imagine - this is the business model of existing countries.

In general, the possibility of a worse outcome than we have now isn't much of an argument against trying something new - if there is also the possibility of a better outcome. The current state of affairs has some pretty serious problems itself, and any increased risks of violence from seasteading countries must be weighed against other decreased risks. So while it is certainly possible that at some time, one seasteading country will wage war on another, and perhaps even likely if seasteading succeeds wildly and there are a wide variety of governments, the relevant questions are:

- Whether aggression between seasteading countries will happen more often than in land-based countries, where war and violence are, shall we say, not unknown.
- If intra-seasteading violence is more frequent, whether it is compensated for by other factors, like decreased violence done by governments to their people. Keep in mind that more people were murdered by their own governments in the 20th century than killed in wars between countries, and that the US imprisons more of its own citizens than any other country in the world.

The Pacifism of Business and Free Association

Steve Tuohy asks:

Given that your ultimate goal is to have numerous Seasteading countries, all of which will presumably have their own form of governments philosophy on social structures; do you think that in the long term there will undoubtedly be conflict between them, with the outcome being a large group of Seasteading countries being under the rule of a few?

Because the population is there voluntarily, seasteading countries will be run more like businesses and less like governments. While businesses aren't perfect, and often cooperate with (or even coopt) the violence of governments, on their own they rarely engage in armed conflict. War drives away trade, and trade is the lifeblood of a business. States go to war because they can use other people to fight (like draftees), and finance it with other people's money. When you have to pay for and fight a war, it will rarely pay. If a seasteading country declares war, then (as David Friedman says), everyone will leave except the generals and war journalists.

I can certainly imagine mergers, but they will be peaceful. And if people don't like the resulting country, they will just leave - that's the whole point of seasteading. If you think too few are ruling too many, then start a new country, and if people agree with you, it will prosper. I don't think that seasteading will fix everything bad about the world - far from it - but I do believe that war for territory happens because of the fixed nature of geography on land, a characteristic not shared by the ocean.

Defense

We would certainly encourage seasteading countries to take precautions against becoming victims, such as:

- Having defensive weaponry like rifles and small ship-to-ship missiles.

- Relying on volunteer, rather than professional, soldiers (citizen militias rather than Blackwater or an army). This disperses military power among the populace, and is so important for preventing tyranny that the founders of the US mentioned it in the Bill of Rights.
- Avoiding societies where military power accumulates in a few hands, whether they be private, as implied by "a few of the richer members", corporate, as in "Blackwater", or public, as happens when citizens leave defense entirely to the police and army. Note that the modularity and mobility of seasteads makes this a much easier proposition than on land. If a seasteader doesn't like the way things are going, they can always take their seastead and leave for a friendlier group.
- Forming loose cooperative alliances with other seastead-cities for mutual defense.

It is our belief that these measures will suffice to make seasteads less physically dangerous than many existing countries. But you don't need to just trust us on this one. If you think seasteads will degenerate into violence, then you can stay home. Those of us who think this new way of life is worth a go will try it, and we can all see whether war and violence are any more common among seasteads than on land. Experimentation will provide the ultimate proof, not argument.

58.3 It's just a bunch of rich guys wanting even more freedom

(This answer was written by TSI's Director of Development Liz Lacy)

Recently I saw a blog post from someone who had heard about seasteading and was turned off by the idea, describing it as "a bunch of rich, entitled white guys wanting even more freedom and entitlement." Now, I can understand that response, in fact I'd be lying if I didn't say that my first response to the idea was somewhat similar. Initially, I thought of it as a sort of "opt out" solution that would benefit a tiny group of people, while doing nothing for the rest of the world.

In my case at least, that initial response was simply a matter of a lack of serious consideration, and a lack of understanding of the mission of TSI. The Seasteading Institute does not propose to simply provide an opt out solution to the wealthy and dissatisfied, we plan to widen the range of options that exist to the world as a whole.

Will the first people to benefit from seasteading be the privileged few who can afford to invest in a strange new pioneering lifestyle? Almost certainly yes, but early adopters always pay for the right to be there at the beginning, and their adoption of a technology or new system of government makes it more accessible to the rest of the world.

There are, without a doubt, people who are interested in seasteading for purely selfish reasons. They want a better, freer life for themselves and they don't have much concern for the rest of society. I suspect however, that these people are in the minority, because there are easier, more immediate ways for an individual to grab freedom for themselves. Seasteading isn't about grabbing greater individual freedom, it's about providing an opportunity for a freer society.

One can argue that the founding fathers of the United States were a bunch of entitled white guys who wanted more freedom and entitlement, and there is certainly some truth to that, but we know that they wanted more than just lower taxes for their poker buddies. How do we know that? Simple.

"We hold these truths to be self-evident, that all men are created equal."

What they were holding as self-evident was an idea sufficiently radical that I suspect there was a certain amount of irony in the way the framers chose to phrase it. Yes, they were wealthy and entitled, and yes they were interested in their own freedoms, but that didn't prevent them from being interested in freedom for everyone, and they created something new that reshaped not only their lives and the lives of the people who joined them, but also the face of politics and ethics around the world.

What will be the self-evident truths of seasteading? Will the crazy, far-fetched idea that it should be easy to form your own government be as obvious in a few centuries as life, liberty and the pursuit of happiness are today? These are not questions that spring from our entitlement or our self-interest, but from our passion to change the world. We have looked at the governments of the world and found that there are questions left unanswered, problems that linger unsolved. Seasteading is not about opting out and ignoring those problems, it is about tackling those tough ethical questions head on and fighting until the answers are simply, self-evident.

Part XI

Finale

Chapter 59

Final Summary

{ Currently this section is being used as a final sales pitch for the project. Should it say other things too? }

While we have made it very clear that the seasteading movement faces substantial challenges, we hope you have also been convinced that it is possible and worthwhile. Further, that the gains from bringing this ambitious vision to life substantially exceed the costs. While this may lack the dramatic appeal of those who claim that the world is utterly doomed to some horrid fate unless their call is heeded, we think our version is more believable.

One thing to notice is that there are many prophets of doom, each preaching a different path to salvation. Seasteading enables any of these movements with sufficient funds and followers to progress from words to actions. Aside from the cynical observation that we can learn something from which groups attempt this transition, we will learn even more from the results. Seasteading turns the ocean into a laboratory for societal innovation.

Nor do any but a few dedicated founders need to pledge life, fortune, and sacred honor to help this movement. The rest of you can simply put some money aside, and buy a timeshare when the time comes. Instead of spending your vacation escaping civilization, get away and help foster change at the same time.

Chapter 60

Acknowledgements

{Acknowledgements go here.}

Patri: Sean Hastings, Charles, Rob & Anna P., David F., Shannon, Katy, Treasa, Milton & Rose, Wayne, Andy H., Eric Hunting, Paul Spooner, Flaviu, Ian Sawyer, Erwin Strauss. Daniel Burfoot wrote the pipeline to get the book from my authoring program (Scrivener) into a printable PDF. Wayne?

Everyone who has commented on any book draft or post, thus giving us food for thought.

While we disagree with the predictions of environmental apocalypse made by many environmentalists, we owe them a great debt. The environmental movement has given momentum to the development of energy-efficient technologies, renewable energy harvesting, recycling, and other technologies which are extremely useful for seasteading. While we are unconvinced that these ideas for conserving resources on land are necessary in that resource-rich environment, in our resource-poor environment we couldn't live without them.

Chapter 61

References

TODO: Write script to add anchors to all references.

If you are reading a printed version of this book, note that all of these references can be found in HTML form at http://www.seasteading.org/book_beta/, if you'd like to be able to just click on web links.

[AB.Hydro] A & B Hydroponics International Pty Ltd, an Australian hydroponics equipment manufacturer. URL: <http://www.abhydroponics.com.au/>

[ADS] Agua del Sol manufactures solar water stills. URL: <http://www.aguadelsol.com/aguadelsol/solar.html>

[AHDE4] *The American Heritage Dictionary of the English Language: Fourth Edition* Houghton Mifflin Company, 2000.

[AlexanderUnp] Alexander, Kevin P. *Ten Thousand Nations*. Forthcoming book. URL: <http://www.alexandisle.org/html/Overview/TenThousandNations.htm>

Alexandisle (section 11.2) Alexandisle, a nation-founding project based on agnostic libertarian principles. URL: <http://www.alexandisle.org/html/GetInvolved/SaveLiberty.htm>

[Allen200508] Christopher Allen, *Dunbar & World of Warcraft*, from the blog Life With Alacrity. URL: http://www.lifewithalacrity.com/2005/08/dunbar_world_of.html

[AmericanHydroponics] American Hydroponics company, Arcata, CA. URL: <http://www.amhydro.com/>

[Andrew1994] *How To Get Started in Hydroponics: Five Systems That Work*, by Scott Andrew. Accent Homegrown Hydroponics (Gold Coast) Pty Ltd. URL: <http://members.ozemail.com.au/~accent/five.html>

[APS2000] *One Man's Crusade to Exonerate Hydrogen for the Hindenburg Disaster*, American Physical Society News, July, 2000. URL: <http://www.aps.org/apsnews/0700/070004.html>

[AquaCone] Aquacone floating solar still URL: http://www.greenhome.com/products/appliances/water_filters/106608/

[Atlantis1994] The Atlantis Project by Eric Klien. URL: <http://www.oceania.org/>

[Avery1992] *Upwelling Pumping Device*, Dr. Don E. Avery, Professor Emeritus, University of Hawaii. International OTEC Association Newsletter, Vol. 3, No. 4 (Winter 1992). URL: <http://ioa.erl.itri.org.tw/vol3-4.htm>

[Bailey1995] Ronald Bailey: 1995. *The True State of the Planet* (New York: Simon & Schuster - Free Press) ISBN: 0-02-874010-6

[BallardWatchTower] In episode 1207 of Scientific American Frontiers, Ballard spends a couple of minutes discussing the idea.

[Banham1976] Reyner Banham: 1976 *Megastructures, urban future of the recent past* (London: Icon (Harper)) ISBN: 0064303713

[Bartholomew1981] Mel Bartholomew: 1981. *Square Foot Gardening* (Emmaus PA: Rodale Press) ISBN: 0-87857-341-0

[Batty2001] *Euthanasia ship to set sail for UK*, David Batty, June 19, 2001. The Guardian. URL: <http://society.guardian.co.uk/print/0,3858,4206151-105965,00.html>

[Bascom1980] Willard Bascom. *Waves and Beaches* 1964 (1st edition) 1980 (2nd edition). Anchor Press/Doubleday, Garden City, New York.

[Behar2002] *Into the Abyss: Building A Deepwater Live-work Lab* by Michael Behar, Wired Magazine, July 2002. URL: <http://www.wired.com/wired/archive/10.07/start.html?pg=7>

[Behrman1992] Behrman, Daniel (with John D. Isaacs). *John Isaacs and His Oceans*. American Geophysical Union, ICSU Press, 1992. ISBN 0-87590-769-5

[Bikini] The Bikini Island Atoll. URL: <http://www.bikiniatoll.com/>

[Bomb2001] Stephano Basilico interviews artist Andrea Zittel in BOMB magazine, March, 2001. URL: http://www.zittel.org/texts/basilico_bomb.html

[Bradley2000] *Potential of Simplified Hydroponics to Provide Urban Agriculture Income*. Peggy Bradley (Institute for Simplified Hydroponics, Corvallis, Oregon) and Cesar Marulanda (UN FAO and UNDP, Armenia, Colombia). November 27, 2000. URL: <http://www.fao.org/ag/ags/agsm/sada/asia/DOCS/DOC/Bradley1.doc>

[Bradley2001] *Potential of Simplified Hydroponics to Reduce Poverty and Hunger in Mexico*. Peggy Bradley (Institute for Simplified Hydroponics, Corvallis, Oregon) and Cesar Marulanda (UN FAO and UNDP, Armenia, Colombia). April 21, 2001. URL: <http://www.carbon.org/Mexicoish/mexico1.htm>

[Canright] *OCEAN UPWELLING; So Cold, So Rich With Life* by Anne Canright, California Coast and Ocean, ISSN: 1052-5823. URL: <http://www.ocean98.org/cacoast2.htm>

[CEC.Solar] URL: http://web.archive.org/web/20030212174454/http://www.consumerenergycenter.org/buydown/solar_faq.html

[Celestopea] URL: <http://www.celestopea.com/>

[CET] Creative Energy Technologies Sustainable Living Catalog. URL: <http://www.cetsolar.com/>

[Chandler] *Energy for the Soviet Union, Eastern Europe and China*, William U Chandler et al., Scientific American, September, 1990

[Chui2000] *The Perfect Storm*, by Glenda Chui, published July 4, 2000, in the San Jose Mercury News.

[Clark2001] Personal correspondence with Rich Clark, Berkeley California.

[Clarke1976] Robin Clarke: 1976. *Building for Self Sufficiency* (New York: Universe Books) ISBN: 0-87663-945-7

[CNN_Sky_02] *ElcomSoft verdict: Not guilty* by Lisa Bowman. SNET, 12/17/02. URL: <http://news.com.com/2100-1023-978176.html>

[CoHoCo] The CoHousing Company, an architecture and development consulting firm for intentional communities. URL: <http://www.cohousingco.com/>

[ConcreteProducts1998] *Concrete Products news & Developments*, Aug 1, 1998 (Vol. 30) URL: http://concreteproducts.com/mag/concrete_news_developments_30/

[Corey1969] Richard C. Corey, ed: 1969. *Principles and Practices of Incineration* (New York: John Wiley & Sons) ISBN: 0471174300

[CSPIQuorn] The Center for Science in the Public Interest's website on complains about Quorn, a protein made from fungus. URL: <http://www.cspinet.org/quorn/>

[Davidson1987] Davidson, Joel: 1987. *The New Solar Electric Home* (Ann Arbor: AATEC Publications) ISBN: 0-937948-09-8.

[DavidsonMogg] James Dale Davidson and Lord William Rees-Mogg: 1997. *The Sovereign Individual: How To Survive And Thrive During The Collapse Of The Welfare State* (New York, NY: Simon & Schuster) ISBN: 0-684-81007-7.

[Defcon_Havenco] *Havenco: what really happened*, slides accompanying a talk by Ryan Lackey, 3 August, 2003, Defcon 11, Las Vegas, CA. URL: <http://www.metacolo.com/papers/dc11-havenco/dc11-havenco.pdf>

[DeSoto2000] De Soto, Hernando: 2000. *The Mystery of Capital: Why Capitalism Triumphs in the West and Fails Everywhere Else*. ISBN: 978-0465016143

[Doblin2002] A Clinical Plan for MDMA (Ecstasy) in the Treatment of Post-Traumatic Stress Disorder (PTSD): Partnering with the FDA by Rick Doblin, Ph.D. URL: <http://www.maps.org/research/mdmaplan.html>

[Dyke1999] *LEGAL STATUS OF ISLANDS - WITH REFERENCE TO ARTICLE 121(3) OF THE UN CONVENTION ON THE LAW OF THE SEA*, by Jon M. Van Dyke, William S. Richardson School of Law, University of Hawaii at Manoa, Honolulu, Hawaii USA. Pub. Seoul, Korea, December 9, 1999 URL: <http://www.seastead.org/localres/misc-articles/DykeLegalStatusOfIslands.html>

[Eckart1996] Eckart, Peter: 1996. *Spaceflight Life Support and Biospherics* (Microcosm Press / Kluwer Academic Publishers) ISBN: 1-881883-04-3

[EcoWaste] Eco Waste Solutions manufacturers the Eco Waste Oxidizer line of incinerators. URL: <http://www.ecosolutions.com/default.htm>

[ElectricBoats] Webpage on Electric Boats and Solar Electric Boats, including manufacturers, conversion, plans, and component suppliers. URL: <http://www.mindspring.com/~jimkerr1/sebebts.htm>

[Energetech] Energetech, a renewable energy company focused on wave power. URL: <http://www.energetech.com.au/>

[EnergyIslandCost] Cost Implications of Combined Power Generation and Seawater Desalination by OTEC, Dominic Michaelis, Jerome Tomasi of www.EnergyIsland.org. URL: <http://sites.google.com/a/energyisland.org/energy-island/OTEC-Cost-Implications>

[EPSEASStill] El Paso Solar Energy Association - Solar Water Purification Project. URL: <http://www.epsea.org/stills.html>

[ERA40] *ERA40 - Validation of the Hydrological Cycle*, at the Max Planck Institute for Meteorology. URL: <http://www.mpimet.mpg.de/en/depts/oam/ls/hc/era/>

[ESA2004] *Ship-sinking monster waves revealed by ESA satellites*, July 21, 2004. URL: http://www.esa.int/export/esaEO/SEMOKQL26WD_index_0.html Local copy URL: http://www.seastead.org/localres/misc-articles/ESA_Rogue_Waves_07_21_04.html

[Fay1991] Fay, James A. and Sonwalkar, Nishikant: 1991. *A Fluid Mechanics Hypercourse*. (Massachusetts Institute of Technology CDROM). URL: <http://www.mas.ncl.ac.uk/~sbrooks/book/nish.mit.edu>

[Fisher1985] Fisher, Jon: 1985. *The Last Frontiers on Earth: Strange Places Where You Can Live Free* (Port Townsend, WA: Loompanics Unlimited). ISBN: 0-915179-24-5, LOCCCN 84-52484. Publishers URL: <http://www.loompanics.com/>

[FitzGerald2006] FitzGerald, Jerome: 2006. *Seasteading: A Life of Hope and Freedom on the Last Viable Frontier*. iUniverse, Inc, ISBN 978-0595387588

[Fitzpatrick1998] *Tutorial: Legal Issues of Ocean Cities* by Cordula Fitzpatrick. Paris, June 11, 1998. URL: http://2100.org/w_oceancitieslegal.html Local copy URL: http://www.seastead.org/localres/misc-articles/fitzpatrick_ocean_cities.html

FloatingHomes (section 9.1) URL: <http://www.floatinghomes.org/>.

- [FloatingHomesTour] In June 2004, Patri took a tour of the Sausalito Floating Homes in Richardson Bay, this is a trip report. URL: <http://www.livejournal.com/users/seasteading/12021.html>.
- [FloatInc] Float Incorporated, designers of the Pneumatically Stabilized Platform. URL: <http://www.floatinc.com/>
- [FrescoResume] The resume of Jacque Fresco, principal of The Venus Project. URL: http://thevenusproject.com/vp_jac/resume.htm
- [Friedman1989] Friedman, David D: 1989. Machinery of Freedom: Guide To A Radical Capitalism, 2nd ed. (La Salle, Illinois: Open Court Publishing). ISBN: 0812690699 URL: http://www.daviddfriedman.com/Libertarian/Machinery_of_Freedom/MofF_Contents.html
- [PFriedman2004] *Dynamic Geography: A Blueprint for Efficient Government* by Patri Friedman. URL: http://clevername.net/patri/socs/commented/drawer/dynamic_geography.html
- [FootnotesToHistory] Footnotes To History: The nations you didn't learn about in high school geography, by James L. Erwin. An excellent webtext. URL: <http://www.buckyogi.com/footnotes>
- [Fox03] *Methane Bubbles Could Sink Ships, Scientists Find*, by Maggie Fox, Health and Science Correspondent, Reuters, 10-22-03. URL: http://www.seastead.org/localres/misc-articles/methane_reuters_10-22-03.html
- [FreedomShip] URL: <http://www.freedomship.com/>
- [Freedonia] URL: <http://www.freedonia.org/>
- [GCRA] Global Coral Reef Alliance URL: <http://globalcoral.org/>
- [Gipe1999] Gipe, Paul: 1999. Wind Energy Basics: A Guide to Small and Micro Wind Systems Chelsea Green Pub Co. ISBN: 1890132071
- [Gjetnes2000] *The Legal Regime of Islands in the South China Sea*, by Marius Gjetnes. Fall 2000 Masters Thesis, Department of Public and International Law, University of Oslo, Norway. URL: <http://www.seastead.org/localres/misc-articles/GjetnesThesis.pdf>
- [Gluckman1996] *Waterworld* by Ron Gluckman, Wall Street Journal, December, 1996. URL: <http://www.gluckman.com/Waterworld.html>
- [GMBD] *Global Maritime Boundaries Database*, produced by Veridian (a subdivision of General Dynamics), is a CD-ROM containing a GIS database of global maritime claims, including territorial seas, contiguous seas, fishing zones, economic zones, disputed areas, etc. Current cost is \$1500/year. URL: <http://www.veridian.com/offering/suboffering.asp?offeringID=526>
- [Goswami2003] *Analysis of an innovative water desalination system using low-grade solar heat*, by S. Al-Kharabsheh, D. Yogi Gaswami. Desalination (pub. Elsevier Science), Vol. 156 (2003), pp. 323-332. URL: <http://www.desline.com/articoli/5143.pdf>
- [Gramlich1999] *Seasteading - Homesteading the High Seas* by Wayne C. Gramlich. Web Site: <http://web.gramlich.net/projects/oceania/seastead1.html>.
- [GreenpeaceKyoto] *U.S. Withdraws From Kyoto Protocol, Europe Forging Ahead With Work On Global Warming, Greenpeace Urges U.S. Businesses To Reject Bush Reversal On Global Warming* URL: <http://www.greenpeaceusa.org/features/kyotonotext.htm>
- [HammacherSchlemmer] Hammacher Schlemmer catalog. URL: <http://www.hammacher.com/>
- [Hasson1988] Dennis F. Hasson, and C. Robert Crowe (ed.): 1988. Materials for Marine Systems and Structures (London: Academic Press) ISBN: 0-12-341828-3)
- [Hawkes] Hawkes Ocean Technologies - Deep Flight Winged Submersibles URL: <http://www.deepflight.com/subs/index.htm>

[Helvarg2001] *Oil and Water* by David Helvarg in Popular Science August 2001 (Vol. 259 No. 2) pp 44-50.

[Hilbertz] URL: <http://mather.ar.utexas.edu/Staff/swaffar/hilbertz/cpfindex.htm>

[Hilbertz1979] *Electrodeposition of Minerals in Sea Water: Experiments and Applications*, IEEE Journal of Oceanic Engineering, Vol. OE-4, No. 3, (July 1979), p.98.

[Hill1993] *Voyaging on a Small Income* by Annie Hill, published in 1993 by Tiller Publishing (URL: <http://www.tillerbooks.com/>) ISBN: 0-9610396-5-5.

[Himawari] Himawari fiber optic light collection and distribution system by Laforet Engineering Co. URL: http://www.himawari-net.co.jp/e_page-index01.html

[Hinman1996] *Salt water could be key to greener world* by Al Hinman. June 18, 1996, CNN.com. URL: http://www.cnn.com/TECH/9606/18/t_t/saltwater.farms/

[HIPAA1996] Health Insurance Portability & Accountability Act, US law passed in 1996. URL: <http://cms.hhs.gov/hipaa/hipaa1/content/hipaasta.pdf>

[Hoff2003] *Immediate-type hypersensitivity reaction to ingestion of mycoprotein (Quorn) in a patient allergic to molds caused by acidic ribosomal protein P2*. Hoff M, Trueb RM, Ballmer-Weber BK, Vieths S, Wuethrich B. Department of Allergology, Paul-Ehrlich-Institut, Langen, Germany. Journal Allergy Clinical Immunology, 2003 May;111(5):1106-10. URL: http://www.ncbi.nlm.nih.gov/entrez/query.fcgi?cmd=Retrieve&db=PubMed&list_uids=12743577&dopt=Abstract

[Hoover2003] *HERE COMES THE SUN: ENGINEERS DEVELOP SOLAR DESALINATION SYSTEM* by Aaron Hoover. University of Florida News, Sept. 16, 2003. URL: <http://www.napa.ufl.edu/2003news/solar-desal.htm>

[HouseBoats] URL: <http://www.houseboats.com/>

[Hunting] Eric Hunting's weblog, entitled *Shelter: Documenting a personal quest for non-toxic housing*. URL: <http://radio.weblogs.com/0119080/>

[Hunting2001] *Aquarius Rising : a conventional approach*, by Eric Hunting, 5/2001. URL: <http://www.angelfire.com/mac/docs/ARcondo.html>

[HydroHistory] History of Hydroponics by Gary V. Deutschmann, Sr. 1967, rev. 1998 URL: http://www.hydomall.com/happy_grower20.html

[ICCPiracy2001] Excerpts from the International Commerce Commission's 2001 Piracy Report URL: http://www.iccwbo.org/home/news_archives/2002/excerpt_trends.asp

[IcyBall] Webpage describing the Crosley IcyBall URL: http://www.ggw.org/~cac/IcyBall/crosley_icyball.html

[IMF] International Marine Floatation Systems Inc. builds floating homes, marinas, docks, walks, and have even built entire floating home subdivisions in Vancouver. URL: <http://www.floatingstructures.com/>

[Incinolet] Incinolet brand electric incinerating toilet URL: <http://www.incinolet.com/>

[Iniki] Hurricane Iniki. URL: <http://home1.gte.net/rhashiro/iniki.htm>

[Intentional Communities] Intentional Communities. URL: <http://www.ic.org/>

[IntLawDict] *International Law Dictionary & Directory*, by Ray August, available online. URL: <http://august1.com/pubs/dict/index.shtml>

[IPS1999] *Environmentalists and trade union leaders have called for urgent action by governments to end 'pirate' fishing in the world's oceans*. Inter Press Service (IPS), United Nations, Apr. 25th, 1999. URL: http://www.seastead.org/localres/misc-articles/end_flag_con_04_25_1999.html

[Island] The Island Foundation: an organization dedicated to the creation of a culture based on Aldous Huxley's last novel, called *Island*. URL: <http://www.island.org/>

[ITDGStill] The Intermediate Technology Development Group's technical paper on solar distillation, oriented towards poor third-world countries. URL: www.itdg.org/html/technical_enquiries/docs/solar_distillation.pdf

Local copy of the document

[ITDGSolar] The Intermediate Technology Development Group's technical brief on Solar Water Heating. URL: http://www.itdg.org/html/technical_enquiries/docs/solar_water_heating.pdf

[JAGS.10.2004] *Cruise Ship Care: A Proposed Alternative to Assisted Living Facilities*, Journal of the American Geriatrics Society, Vol. 52 Issue 11 Page 1951, November 2004. URL: <http://www.blackwell-synergy.com/doi/abs/10.1111/j.1532-5415.2004.52525.x>

[Jenkins1999] Joseph Jenkins: 1999. *The Humanure Handbook: A Guide to Composting Human Manure* (Grove City, PA: Jenkins Publishing). ISBN: 0964425890. URL: <http://www.weblife.org/humanure/default.html>

[JETRO-Cap] *New Capacitors Promise Huge Increase In Electrical Storage Capacity*, author unknown, 11/18/03. Japan External Trade Organization - Feature Article. URL: http://www.jetro.go.jp/ec/e/articles/market/docs/2003_12_capacitor.html

[Jewell2001] William J. Jewell. *SUSTAINABLE WATER IN CLOSED BIOSYSTEMS: Preliminary Design Considerations*. Presented at The High Frontier Conference XV." May 8, 2001. Princeton University, Princeton, New Jersey. Sponsored by the Space Studies Institute. P.O. Box 82, Princeton, NJ 08542 URL: http://www.ssi.org/SSI05_08_01_Paper.pdf

[Jules] Jules Underwater Lodge, Key Largo, Florida URL: <http://www.jul.com/>

[JungThesis] *A Study on the Arrest of Ships*, by Hae Duk Jung. A PhD thesis at Kyung Hee University in Seoul, Korea. URL: http://www.seastead.org/localres/misc-articles/Jung_arrest_thesis.html

[Kaiser2000] *Impact Resistance of Laminate Glass Using Sacrificial Ply: Design Concept*, Nathan Kaiser, Richard Behr, Joseph Minor, Lokeswarappa Dharami, Paul Kremer. Journal of Architectural Engineering, March, 2000. Summarized in *Engineers find new ways to protect against hurricane damage* - by Curtis Chan, Penn State. URL: <http://www.globaltechnoscan.com/27thDec-2ndJan/hurricane.htm>

[Kardol1999] *Proposed Inhabited Artificial Islands in International Waters: International Law Analysis in Regards to Resource Use, Law of the Sea and Norms of Self-Determination and State Recognition* by Rene Kardol. MA Thesis, Universiteit van Amsterdam, March, 1999. URL: <http://www.luf.org/artisle.html> Local URL: <http://www.seastead.org/localres/misc-articles/kardol1999.html>

[Kopel2001] *The Prohibitionist's Burden: Congress has repealed the Fourth Amendment for everyone on a ship* by Dave Kopel, National Review Online, July 10, 2001. URL: <http://www.nationalreview.com/kopel/kopel071001.shtml>

[Kozlowski2002] *Onsite Options: Facilities explore new technologies, cost benefits and the maintenance impact of onsite power alternatives* by David Kozlowski, Senior Editor. Maintenance Solutions magazine, March, 2002. URL: <http://www.facilitiesnet.com/MS/Mar02/mar02power.shtml>

[LandfallStill] Landfall Navigation's Solar Still URL: <http://www.landfallnavigation.com/memss.html>

[Lange2004] Langewiesche, William: 2004. *The Outlaw Sea* (New York, NY: North Point Press). ISBN: 0865475814.

[Lawton2001] Lawton, Graham: 2001. *Monsters of the Deep*, New Scientist magazine, vol 170 issue 2297, 6/30/2001 URL: [/seastead.org/localres/misc-articles/lawton_newsci_06_30_01.html](http://seastead.org/localres/misc-articles/lawton_newsci_06_30_01.html)

[Lee] Eric Lee's analysis of seament power requirements. URL: <http://www.stanford.edu/~erlee/seament/seam>

[LFC] Laissez-Faire City is now defunct, however Scamdog's report gives an excellent picture of its history URL: http://www.scamdog.com/freedom_projects/?view=laissez_faire_city

[LIIAdmiralty] An overview of admiralty law from Cornell's Legal Information Institute URL: <http://www.law.cornell.edu/topics/admiralty.html>

[MaritimeClaims] Maps.com World Factbook - list of Maritime claims. URL: <http://www.maps.com/reference/geoshelf/factbook/fields/2106.html>

[MBR] The Best Hydroponics Book, vol 1, by MBR. ISBN: 0-9687063-0-4 URL: <http://hydroponics.hypermart.net/book.html>

[McBee2002] *South has become a gambler's delight*, Julia McBee. Atlanta Journal-Constitution, 2002 Travel Go Guide - gambling section. URL: <http://www.ajc.com/travel/content/travel/goguide2002/gambling.html>

[McCormick1981] Michael P. McCormick: 1981. *Ocean Wave Energy Conversion* (New York: John Wiley & Sons) ISBN: 0-471-08543-X

[McDonough2002] William McDonough and Michael Braungart: 2002. *Cradle to Cradle* (North Point Press) ISBN: 0-86547-587-3

[McGuigan1981] Dermot. McGuigan: 1978. *Harnessing the Wind for Home Energy* (Charlotte VE: Garden Way Publishing) ISBN: 0-88266-117

[MDI] The Monolithic Dome Institute is an excellent resource for concrete dome construction. URL: <http://www.monolithic.com/>

[MDI.Ivan] The Monolithic Dome Institute's index of news stories covering how well domes withstood the 2004 hurricanes. URL: <http://www.monolithic.com/domenews/2004/ivan2.html>

[MediBurn] MediBurn - infectious/pathological waste incinerator. URL: <http://www.elastec.com/incineral.htm>

[MilleniumCell] Millenium Cell develops and manufactures borohydride-based hydrogen storage solutions. URL: <http://www.millenniumcell.com/index.pl>

[Moeller1977] Moeller, Jan and Bill: 1977. *Living Aboard* (Camden, Maine: International Marine Publishing Company). ISBN: 0-87742-079-3.

[MotherEarth2000] *Paper Houses* in *Mother Earth News*, April, 2000. By Gordon and Laura Solberg. URL: http://www.findarticles.com/p/articles/mi_m1279/is_2000_April/ai_60578240

[MotherEarth2001] *Recycling, Homesteading Style* in *Mother Earth News*, Dec/Jan 2001, page 62. The original article was published in the Summer 2000 issue of *The Amicus Journal* published by the National Resources Defense Council.

[Murphy] *Chaos Theory - Two essays on Market Anarchy*, by Robert P. Murphy. Self-published by BooksJustBooks. URL: <http://homepages.nyu.edu/~rpm213/ChaosTheory.html>

[NaturalHistory2003] *Trashed*, Natural History Magazine, November, 2003. URL: http://www.nhmag.com/1103/1103_feature.html

[Nature082001] *The end of world population growth* by Wolfgang Lutz, Warren Sanderson and Sergei Scherbov. *Nature* 412, 543-545 (2 August 2001). URL: <http://www.nature.com/nature/fow/010802.html>

[NatureCon2001] Nature Conservancy Annual Report 2001: Financial Summary for Fiscal Year 2001 URL: <http://nature.org/aboutus/annualreport2001/docs/art7351.html>

[N55BOOK] N55 BOOK, to be published by Pork Salad Press, Copenhagen, Denmark. URL: http://www.n55.dk/MANUALS/N55_BOOK/BOOK.html Many of the sections are available on-line as MANUALS here: URL: <http://www.n55.dk/MANUALS/Manuals.html>

Neumeyer1982 Ken Neumeyer: 1982. *Sailing the Farm: A Survival Guide to Homesteading on the Ocean* (Ten Speed Press) ISBN: 0898150515. Publisher's URL: <http://www.tenspeed.com/>

[NewAtlantis] The Independent Virtual Kingdom of New Atlantis Virtual Kingdom URL: <http://www.new-atlantis.org/> Physical Project URL: <http://www.build.new-atlantis.org/>

[Nexus] Architect Eugene Tsui of Tsui Design Research has proposed this huge, self-sufficient floating-city. URL: <http://www.tdrinc.com/nexus.html>

[NDBC] National Data Buoy Center, part of the National Oceanic and Atmospheric Administration. URL: <http://www.ndbc.noaa.gov/>

[Nisbet1990] *Climate change and methane* Nature, v. 347, p. 23, September, 1990.

[NMHP] DOE - NETL - NMHP: Department of Energy - National Energy Technology Laboratory - National Methane Hydrate Program URL: <http://www.netl.doe.gov/scng/hydrate/>

[Norgrove1983] Norgrove, Russ: 1983. *Blueprint For Paradise: How to Live on a Tropic Island* (McGraw-Hill) ISBN: 0-918373-15-8.

[NWP_LAW] *NAVAL WARFARE PUBLICATION: THE COMMANDER'S HANDBOOK ON THE LAW OF NAVAL OPERATIONS* NWP 1-14M (Formerly NWP 9) FMFM 1-10 COMDTPUB P5800.7. DEPARTMENT OF THE NAVY OFFICE OF THE CHIEF OF NAVAL OPERATIONS URL: <http://www.cpf.navy.mil/pages/legal/NWP1-14/NWP1-14COVER.htm>

[OASIS] *Ocean-Atmosphere-Seaflor Integration Study*, a research proposal which includes underwater Ocean Bases. URL: <http://www.oceantechnology.org/oasis.htm>

[Ozcayir2000] *Flags of Convenience and the Need for International Co-operation* by Dr. Z. Oya Ozcayir. *International Maritime Law Journal*, May 2000, Vol. 7, Issue 4, pp. 111-117. URL: http://www.turkishpilots.org/DOCUMENTS/Oya_Ozcayir_Flags_Of_Convenience.htm

[NorskeShell] Shell Norway site about the Troll gas platform. URL: http://www.shell.com/home/Framework?siteId=no-no&FC2=/no-no/html/iwgen/leftnavs/zzz_lhn8_7_3.html&FC3=/no-no/html/iwgen/undersokelseproduks/trollgassutbyggingen/factsandfigures_10090930.html

[NorwayRogueGroup] *Freak waves, rogue waves, extreme waves and ocean wave climate*, a webpage about rogue waves by a group of mathematicians at Norwegian universities. The page includes references to their academic articles. *Kristian B. Dysthe, Department of Mathematics, University of Bergen, Norway* *Harald E. Krogstad, Department of Mathematics, NTNU, Norway* *Herve Socquet-Juglard, Department of Mathematics, University of Bergen, Norway* *Karsten Trulsen, Department of Mathematics, University of Oslo, Norway* URL: http://www.math.uio.no/~karstent/waves/index_en.html

[NREL-OTEC] National Renewable Energy Laboratory site on Ocean Thermal Electric Conversion. URL: <http://www.nrel.gov/otec/>

[Patri_FS] Is the Freedom Ship Realistic? Seastead co-author Patri Friedman's webpage collecting arguments against the impracticality of this project. URL: http://patrifriedman.com/projects/independence/fs_other.html

[Patri_NU] Utopia or Scam? - Seastead co-author Patri Friedman's webpage on the evidence against the legitimacy of the Principality of New Utopia. URL: <http://www.patrifriedman.com/projects/independence/newutopia.html>

[PBSZittel] Art:21, Season One, Episode 4: Consumption, on PBS, included an interview with artist Andrea Zittel. URL: <http://www.pbs.org/art21/artists/zittel/clip2.html#>

[Pelagic] The Pelagic Project, a libertarian nation-founding project with an unusually realistic, incremental approach. URL: <http://pelagic.wavyhill.xsmail.com/>

[Perez2001] URL: <http://members.axion.net/~enrique/reedship.html>

[Piolenc2001] Personal communication between Wayne Gramlich and F. Marc De Piolenc.

[PocketProperty] Andrea Zittel's Pocket Property, a small floating home created as an art project. URL: http://www.zittel.org/works/2000/pocket_2000_400.html

[Poseidon] Poseidon Resorts is a planned underwater resort complex, which seems to be connected to US Submarines. URL: <http://poseidonresorts.com/>

[Powerball] Powerball Technologies URL: <http://www.powerball.net/>

[PrivateIslands] URL: http://www.vladi-private-islands.de/home_e.html

[Rand1946] Ayn Rand: 1996 (first published 1946). *The Fountainhead* (Signet, Mass Market Paperback) ISBN: 0451191153

[Rappaort2002] *Science Fiction Meets Fact Under the Sea: A "space station" underwater? It could happen if researchers' dreams become reality.* Jessica Rappaort, TechTV live, October 15, 2002. URL: <http://www.techtv.com/news/print/0,23102,3403357,00.html>

[Ray1965] Thomas W. Ray: March, 1965. *A History of Texas Towers In Air Defense 1952-1964* (apparently unpublished) URL: http://www.texastower.com/a_history_in_texas_towers_air_defense.htm

[Ray1995] Bill T. Ray: 1995. *Environmental Engineering* (Boston, MA: PWS Publishing Co.) ISBN: 0-534-20652-2 LCCCN: 94-26681

[Reagan1983] *Statement on United States Oceans Policy*, speech by President Reagan, March 10, 1983. URL: http://www.seastead.org/localres/misc-articles/reagan_03_10_1983.html

[Resh1978] Howard M. Resh: 1978. *Hydroponic Food Production* (Santa Barbara: Woodbridge Press) ISBN: 0-912800-54-2 LCCCN: 78-23468

[ReutersDubai] URL: [/seastead.org/commented/paper/refs/reuters-dubai.html](http://seastead.org/commented/paper/refs/reuters-dubai.html)

[RingEco] *The Race! Who will be the first to manufacture truly cost-competitive Photovoltaic cells?* by Ed "Redwood" Ring. Ecoworld Global Environmental Community. URL: <http://www.ecoworld.org/Energy/Articles/articles2.cfm?TID=248>

[RogueWaves2000] *Rogue Waves 2000*, 29-30 November 2000, during SeaTechWeek 2000, La Quartz, Brest, France. URL: <http://www.ifremer.fr/metocean/conferences/wk.htm>

[RogueWarning] *Rogue wave warning*, ID28, 08/08/2002, Auckland Rescue Helicopter Trust, Melanie Appleton (Western Leader) URL: http://www.seastead.org/localres/misc-articles/ARHT_appleton_roguewarning.html

[Rose1979] Rose, Pat Rand: 1979. *The Solar Boat Book* (Ten Speed Press, URL: <http://www.tenspeed.com/>) ISBN: 0-9604874-0-9.

[Roselle1996] Rosselle, T. *Seeing Green Under Glass*. The Packer 1996, 103, p. 1A.

[RSLI] Remote Source Lighting International makes fiber optic based light systems. URL: <http://www.remotesource.com/index.html>

[Salsbury1992] *Oceana: A Proposal For A New Country* URL: <http://reality.sculptors.com/~salsbury/Oceana/>

[Savage1992] Marshall T. Savage: 1992. *The Millennial Project: Colonizing the Galaxy in Eight Easy Steps* (Denver: Empyrean Pub.) ISBN: 0-316-77163-5. LCCCN:94-15965

[SeaAroundUs] *The Sea Around Us Project*, a partnership of the Fisheries Center with Pew Charitable Trusts. "The aims of the project are to provide an integrated analysis of the impacts of fisheries on marine ecosystems, and to devise policies that can mitigate and reverse harmful trends whilst ensuring the social and economic benefits of sustain-

able fisheries. ” URL: <http://www.seaaroundus.org/project.htm> URL for EEZ listing: <http://saup.fisheries.ubc.ca/eez/eez.aspx#>

[SeaSolar] Sea Solar Power is designing more efficient OTEC systems. URL: <http://www.seasolarpower.com/>

[ShadowMasons] This is the website of architect Jim Albea, who created the models and rendered the images for Atlantis1994. URL: <http://www.ShadowMasons.com>

[Shipman1989] Shipman, Harry L: 1989. Humans in Space: 21st Century Frontiers (Perseus Publishing) ISBN 0306431718.

[Shulgin1991] Shulgin, Alexander and Ann: 1991. PIHKAL: A Chemical Love Story (Berkeley, CA: Transform Press) ISBN 0-9630096-0-5.

[Shulgin1997] Shulgin, Alexander and Ann: 1997. TIHKAL: The Continuation (Berkeley, CA: Transform Press) ISBN 0-9630096-9-9.

[Sierra1997,] *The Planet Newsletter* 1997 Volume 4, number 1, ”The Sierra Club in 1996: A Statistical Portrait”. URL: <http://www.sierraclub.org/planet/199701/stats.asp>

[Silvertown] *A Silent Spring in China*, by Jonathan Silvertown, New Scientist, 1 July 1989.

[Simpson] Bruce Simpson’s page on building a DIY cruise missile for under \$5,000. URL: <http://www.interestingprojects.com/cruisemissile/>

[SixtiesCityPR] Sixties City - Offshore Pirate Radio URL: <http://www.sixtiescity.com/Radio/PirateRadio.htm>

[SkylabFirst] *Skylab, Our First Space Station*, edited by Leland F. Belew, prepared by the Scientific and Technical Information Office, NASA, Washington, D.C., 1977.

[Skyllas2004] Professor Maria Skyllas-Kazacos at the University of New South Wales, Australia, personal communication.

[SmartAsh] SmartAsh portable incinerator for non-hazardous waste. URL: <http://www.elastec.com/smartash.l>

[Smith1973] Smith, F.G. Walton: 1973. The Seas in Motion: Waves, tides and currents - how they work; their causes and effects (New York, NY: Thomas Y. Crowell Co) ISBN 0-690-72329-6

[SolAqua] SolAqua manufacturers solar stills. URL: <http://www.solaqua.com/index.html>

[SolarIce] *A Solar Ammonia Absorption Ice-maker*, by Jaroslav Vanek, Mark ”Moth” Green, and Steven Vanek. Home Power #53, June/July 1996, pp. 20-24. URL: <http://www.seastead.org/localres/misc-articles/solarice.pdf>

[SOLAS1974] International Convention for the Safety of Life at Sea (SOLAS), 1974 URL: http://www.imo.org/Conventions/contents.asp?topic_id=257&doc_id=647

[SourcingMag2005] *From Offshore to Ship-to-Shore*, Sourcing Mag, 4/5/2005. URL: <http://www.sourcingmag.com/blog/blogdefault.aspx?view=plink&id=383>

[SpaceSettlements] *Space Settlements: A Design Study*, a collaborative document produced by the NASA Ames Space Settlement Design Contest in 1975. URL: <http://www.nas.nasa.gov/About/Education/SpaceSettlement/75SummerStudy/s.s.doc.html>

[SpaceTodayFactoids] Space Factoids from Space Today Online. URL: <http://www.spacetoday.org/History/SpaceFactoids/SpaceFactoids2.html>

[Spirulina1994] Henrikson, Robert: 1994. Earth Food Spirulina (Kenwood, CA: Ronore Enterprises) ISBN 0-9623111-0-3

[SSI] Sea Structures Inc., makers of Seacells URL: <http://members.aol.com/ajbjja/ssi.html>

[Stafford1992] Stafford, Peter: 1992. Psychedelics Encyclopedia (Third Expanded Edition) (Berkeley, CA: Ronin Publishing Inc.) ISBN 0-914171-51-8.

[Staber] Staber Industries manufactures energ-efficient appliances. URL: <http://www.staber.com/>

- [StatsUS1998] *Statistical Abstract of the United States - 1988*
- [StrategicOceans] *The Strategic Importance of the Oceans*, written by the editors of *Maritime Affairs* and published in that magazine. URL: <http://www.dal.ca/~centre/Oceans.pdf>
- [Stratton1969] *Our Nation and the Sea. A Plan for National Action*. Report of the Commission on Marine Science, Engineering and Resources. United States Government Printing Office, Washington, D.C., 305 pp., January 1969. Referred to as the "Stratton Report" after the committee chair. URL: <http://www.lib.noaa.gov/edocs/stratton/contents.html>
- [Strauss1984] Strauss, Erwin S: 1984 *How to Start Your Own Country* (Port Townshend, WA: Breakout Productions Inc.) ISBN: 1-893626-15-6.
- [Sowa] *Plastic Island Paradise* published by The Sun. URL: <http://www.thesun.co.uk/article/0,,5-2002410050,00.html>.
- [SubSeaSystems] "Sub Sea Systems manufactures the finest, state of the art, customized Semi-Submersibles for the tourist industry and private use." URL: <http://subseasystems.com/>
- [SWATHSite] Swath.com, a website about Small Waterplane Area Twin Hull ships. URL: <http://www.swath.com/>
- [TechTopics2000] *Ultra-Light Concrete: The Answer to a Builder's Prayer?* in Michigan Tech's TechTopics, December 8, 2000, Vol. 33, No. 14. Published by University Relations. URL: <http://www.sas.it.mtu.edu/urel/ttopics/textfiles/2000/-Dec-08-00.html#gen75>
- [TexasTowersRD] *Tragedy on Tower Four*, Readers Digest, condensed from True, The Man's Magazine, April, 1962. URL: <http://www.radomes.org/museum/documents/TexasTowerNo4UnnamedSho.html>
- [ThermalDepol] Wikipedia entry on Thermal Depolymerization URL: http://en.wikipedia.org/wiki/Thermal_depolymerization
- [Thoreau1906] *The Writings of Henry David Thoreau*, Houghton Mifflin, 1906. Cited in *The Columbia World of Quotations*, 1996, Number 59180.
- [UNEP1997] *Source Book of Alternative Technologies for Freshwater Augmentation in Latin America and the Caribbean*, United Nations Environment Programme - International Environmental Technology Centre. Issued as a volume in the UNEP-IETC Technical Publication Series, Osaka/Shiga, Japan, 1997. URL: <http://www.oas.org/usde/publications/Unit/oea59e/begin.htm#Contents>
- [UNHBiodiesel] University of New Hampshire Biodiesel Group URL: <http://www.unh.edu/p2/biodiesel/>
- [USAvBustos] United States of America vs. Edilson Bustos-Useche, United States Court of Appeals for the Fifth Circuit, No. 00-20355, Nov. 13th 2001. URL: <http://www.admiraltylawguide.com/circt/5thbustos.html>
- [USGSHydrates] *Gas (Methane) Hydrates - A New Frontier*, September 1992, USGS Marine and Coastal Geology Program URL: <http://marine.usgs.gov/fact-sheets/gas-hydrates/title.html>
- [USGSTsunami] *Life of a Tsunami*, USGS Western Region Coastal and Marine Geology, maintained by Eric L. Geist. URL: <http://walrus.wr.usgs.gov/tsunami/basics.html>
- [VenusProject] The Venus Project aims to redesign world civilization. URL: <http://thevenusproject.com/>
- [UNSW-VRB] University of New South Wales, Australia - Vanadium Redox Battery. URL: <http://www.ceic.unsw.edu.au/centers/vrb/>
- [Water1999] 1999 Residential Water Use Summary, American Water Works Association.
- [WA_Wave] Excerpts from *Solar Plan for the State of Washington - Ocean Wave Energy*. A report to the Solar Planning Office - West, written March 1, 1978, updated July 2003.

Document WSUCEEP03_40, prepared by David Sjoding. Washington State University Cooperative Extension Energy Program, Olympia, WA. URL: http://www.energy.wsu.edu/ftp-ep/pubs/renewables/03_40_Ocean_Wave_Tidal.pdf

[Wick1977] Isaacs wave-energy pump; final report of field tests off the coast of Kaneohe Bay, Hawaii, November 1976 - March 1977. -, Wick Gerald L. and Castel, David, 1977. Department of Planning and Economic Development and Natural Energy Laboratory, University of Hawaii. Note: we have not obtained this reference

[Willis1992] *Jobs for the 21st Century*, by Christopher R. Willis. An online book which is very similar to this paper, but focused on space travel. URL: http://www.androidpubs.com/space_book.htm

[WMD-Legal] *Weapons of Mass Destruction Counterproliferation: Legal Issues for Ships and Aircraft*, Congressional Research Services Report for Congress. Order Code RL32097, October 1, 2003. Prepared by Jennifer K. Elsea, Legislative Attorney, American Law Division. URL: <http://www.fas.org/spp/starwars/crs/RL32097.pdf>

[WorldAquaculture] World Aquaculture webpage URL: <http://www.newmex.com/platinum/data/light/index2.html>

[Wright2000] Wright, Robert: 2000. *Nonzero: The Logic of Human Destiny* (Pantheon Books) ISBN: 0-679-44252-9. URL: <http://www.nonzero.org/>

[Yarris1994] E and E postdoc puts solar technology to work at home, by Lynn Yarris, 9/16/1994, Lawrence Berkeley National Laboratory Research News.

[Zandonella2001] *Gene-modified tomato revels in salty soils* by Catherine Zandonella. July 31, 2001, NewScientist.com news. URL: <http://www.newscientist.com/news/news.jsp?id=ns99991092>

Click below to find more

[Mipaper at www.lcis.com.tw](http://www.lcis.com.tw)

[Mipaper at www.lcis.com.tw](http://www.lcis.com.tw)