

A SELF-RECORDING MAZE

EDWARD C. TOLMAN AND LLOYD A. JEFFRESS

University of California

To those who have spent all too valuable hours from their lives recording by hand the progress of rats through mazes, the desirability of some type of automatically recording maze is only too obvious. Particularly are automatic recording devices imperative for problems in which large numbers of animals must be run. Whenever any refined statistical treatment of the results is necessary, as is the case in investigations of differences of individual ability, such automatic devices are almost a *sine qua non*. In the present paper the writers will describe, as a suggestion to others, and to invite criticism, a type of automatically recording maze which they have constructed and which is being used in this laboratory.¹

The device, as we have designed it, makes use of treads in the maze floor, which, when the rat steps on them, cause electrical contacts which will work an electric counter. In order to prevent additional counts being made if a rat merely jiggles up and down on the same tread without going on an appreciable distance, a further important feature is necessary. This consists in arranging that the *first* contact made by a given tread (which it is desired to record) shall also operate a relay which throws a shunt across the tread contact and thus keeps the counter on until the animal has gone to a certain other tread which is connected so as to break the first circuit.

In the particular arrangement to be reported here, the maze as a whole is built up of separate sections. Each of these sections is made up of three unit-alleys (see fig. 4), each with a tread in its

¹The need for the maze results from a general program for the study of "The Inheritance of Maze-Learning Ability in Rats," vide E. C. Tolman, this Journal, 1924, vol. 4, pp. 1-18.

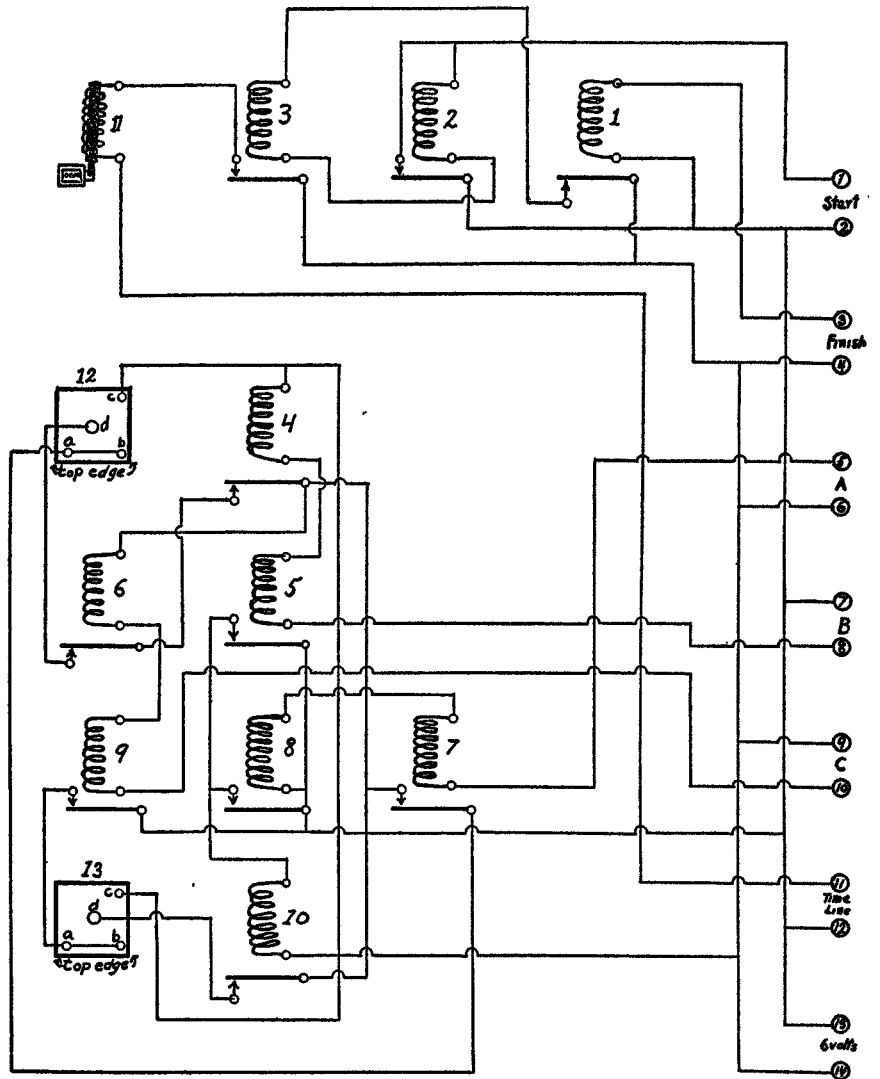

Figure 1

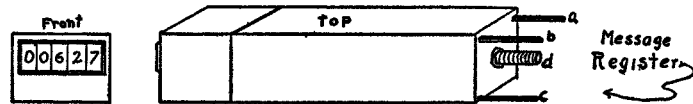

Figure 2

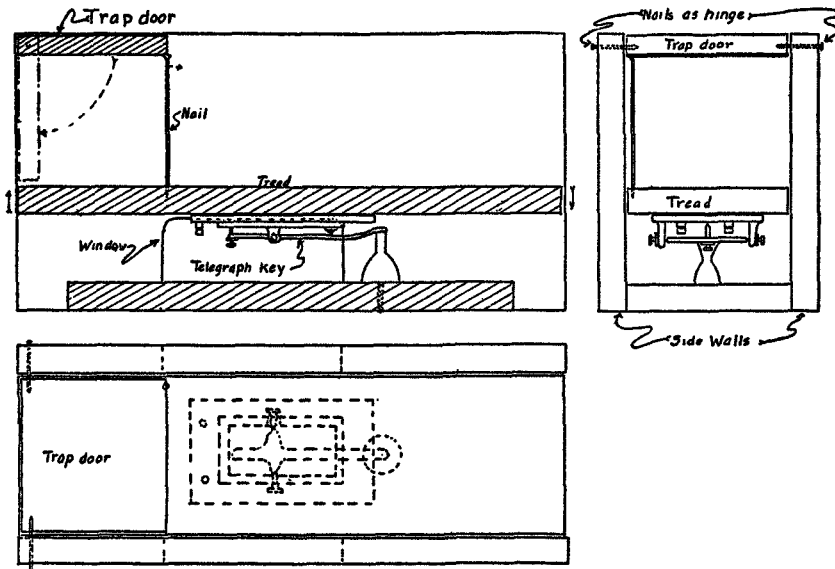

Figure 3

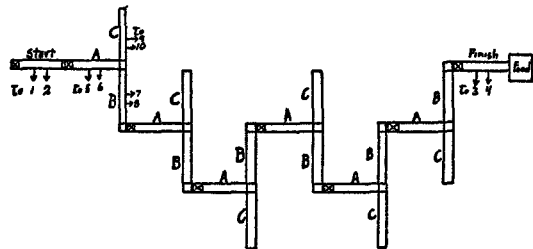

Figure 4

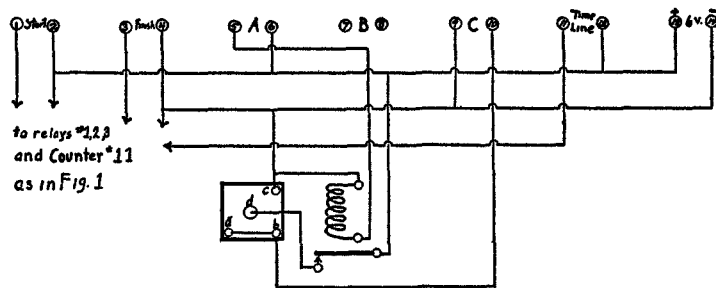

Figure 5

floor. These three unit-alleys are as follows: (1) an entrance alley—*A*; (2) issuing from this on the one side and at right angles, a cul de sac—*C*; and (3) issuing on in opposite direction a true path—*B*. An automatic trap door closes behind the animal when he gets well into an entrance alley, *A*. This serves to separate the sections one from another and prevents retracing from a later section to an earlier one.

The maze shown in figure 4, is of a simple type built rather to test the practicality of the apparatus, than to serve for a particular psychological investigation. It shows one of the many combinations that can be obtained from the units and sections.

The units are built of $\frac{3}{4}$ inch redwood, 15 inches long and $4\frac{1}{2}$ inches wide on the inside. The tread is a sort of false bottom which is fastened to an ordinary telegraph key in such a manner that normally it remains open, but is closed by the weight of a rat² when he is past the center (in the figure, to the right) of the tread. The arrangement of the parts is shown in figure 3. In each of the side-walls of the unit a window is cut to enable one to make connections with the binding-posts of the key. In the units, which the writers had built for them by a mechanic, the key is put in upside down and fastened to the base by means of a specially built metal knob, as shown. It is quite likely that others in constructing a similar piece of apparatus could find a simpler and more economical device.

As explained above, a "section" is a group of three of these units. The entrance to the section is a unit like the one shown in the drawing and is equipped with a trap door like the one illustrated. This door is of the simplest possible construction. It is swung from the side walls by means of two nails, which serve the purpose better than any hinge, and is held in the "set" position by means of a long nail driven into the tread. When the rat passes the middle of the tread his weight causes it to tip, thus moving the nail to the left and removing the support from the

²This type of tread was found by the writers to be much more satisfactory than one which depends upon a spring to keep the contact open. The springs with which the keys were originally equipped were removed before the keys were used for this purpose.

door allowing it to swing shut of its own weight, in the direction indicated by the arrow in the figure. A cloth bumper may be arranged to arrest the door quietly so as to not startle the

The other two units of the section are similar in construction to the above, except that they are without the trap door. The three units may be joined together in any fashion, so long as the new floor is on the same level as the treads, and so long as the grouping is the same, i.e., the entrance through a trap-door-equipped unit, and two alleys leading from it, one a cul de sac, and the other a portion of the true path. In the figure, the units, *A*, *B*, and *C* are shown in the arrangement used in the writers' maze. The location of the trap door is shown by the cross at the front of each of the *A* units.

The unit, in figure 4, labelled, "start" and the one labeled, "finish," are in construction the same as the *A* units, i.e., they are equipped with the door. They are put in to control the time-recording apparatus, and, in addition, the unit at "finish" acts to confine the rat to the food box when he has completed his run.

There are two types of error which a rat may make in a maze arranged as this one is, and each is to be counted separately. One is an entrance into a cul de sac, and the other is a retracing into the already traversed true path. With the apparatus described in this paper these errors are recorded on separate counters, and in addition a record is made of the total time the rat spends in running the maze. The arrangement and connection of this apparatus is shown in figure 1.

The row of circles on the right hand side, in the figure, represent the binding posts to which the keys in the treads of the maze are connected, in the following manner:

1. Is connected to one of the contacts of the key at "start."
2. Is connected to the other contact of the key at "start."
3. Is connected to one of the contacts of the key at "finish."
4. Is connected to the other contact of the key at "finish."
5. Is connected to one of the contacts on each of the *A* units.
6. Is connected to the other contact on each of the *A* units.
7. Is connected to one of the contacts on each of the *B* units.
8. Is connected to the other contact on each of the *B* units.

9. Is connected to one of the contacts on each of the *C* units.
10. Is connected to the other contacts on each of the *C* units.
11. Is connected to one contact of a time clock marking seconds.
12. Is connected to the other contact of the clock.
13. Is connected to one side of a six-volt storage battery.
14. Is connected to the other side of the storage battery.

From a consideration of the above connections it is evident that when the rat passes through any *A* unit he will cause a connection to be made from 5 to 6; when he passes over a *B* unit he will connect 7 to 8, etc.

In figure 1, the relays numbered 2, 3, 5, 7, 8, 9, are simple telegraph relays with a resistance of about 10 ohms, and with the contact-points arranged as usual so that a connection is made by them when the relay is actuated. The others, numbers 4, 5, 10, are the same kind of relay but have their contact points reversed so as to make the connection when at rest and break it when actuated.

Numbers 12 and 13 are "message registers" made by the Western Electric Company. The type employed by us is No. 5 H, 0.27 ohms³ and costs five dollars. The instrument is a combination of an electric counter and a shunt contact which can be utilized to keep the counter in the closed position until the circuit is broken, by one of the relays. An additional relay and a simple electric counter may be used in place of the message register, though the writers have been unable to find a counter which combines the advantages of a moderate current consumption and a moderate price.

Number 11 in the figure is an electric counter. Any type of counter, so long as it will operate on six volts, will suffice. If a counter were being purchased especially for this purpose it would be advisable to get another of the message registers and make the connections to poles *a* and *c*.

The operation of the apparatus is as follows. When the rat closes the key at "start" the current from the storage battery flows to the binding post 2, from 2 to 1 through the tread in the

³ Due to the low resistance of this counter it may be necessary to insert a few ohms resistance in the circuit to prevent overheating of the coils. If this is necessary it should be inserted between post *c* and the wire which connects to it.

maze, and from 1 to relays nos. 2 and 3, and thence back through the contacts of relay no. 1 to the other side of the battery, 14. This actuates both nos. 2 and 3. The contacts of no. 2 shunt the current from the key in the maze and hence keep the relay closed, and necessarily no. 3 also is kept closed. Through the contacts of no. 3 the counter no. 11 is connected to the clock and battery circuit, so that the counter registers each beat of the clock as long as the relay remains closed. When the rat enters the trap at "finish" he causes a connection from 3 to 4 which actuates relay no. 1. This breaks the circuit through the coils of nos. 2 and 3, and allows their armatures to fall back and break the clock circuit through the counter. By this means a record is obtained of the number of seconds the rat spends in traversing the maze.

The rest of the apparatus is involved in counting the number of errors made by the rat during the run. When the rat has passed the balance point of *A*, a connection is made from binding post 5 to 6, which allows the current to flow from the battery through relays nos. 7 and 8. Through the contacts of relay no. 7 a current flows to the register no. 12 from *ab* to *c*. This actuates the counter, and also makes a connection within the register itself which causes the current to continue to flow through the magnet via the path *d* to *c*. Thus since the current is already flowing through the coil, no further action of relay no. 7 can produce any effect. This prevents the counting of any accidental contact, such as would be made if the rat merely jiggled up and down on the tread.

Suppose that now the rat enters the portion of the true path at *B* and passes the balance point. Relay no. 4 will break the circuit through *d-c* and allow the armature of the message register no. 12 to fall back to its original position. This leaves it in condition to record another entrance into *A*.

A perfect run would take place as follows: When the rat passes the first *A*, counter no. 12 will record one entrance, when he passes over *B*, the armature of no. 12 will return to its original position, when he passes the next *A*, the register will record another entrance, and so on. From this it is evident that a perfect run must necessarily be recorded as six counts on the register no. 12. Thus

we must subtract six (if six is the number of choices) from the score on no. 12, in order to ascertain the number of errors made by the rat in his run.

Suppose, however, that the rat instead of going directly to the second *A*, from *B*, were to retrace his path and re-enter the first *A*. He would score an error in addition to the minimal six. If from there, *A*, he were to go into *C*, two things would happen; the circuit *d-c* of register no. 12 would be broken, this time through the agency of relay no. 6, and register no. 13 would be closed by means of the contacts of no. 9. This records one error on register no. 13 and at the same time puts no. 12 into position to record another entrance into *A*. Register no. 13 works in the same fashion as no. 12, in that once closed, it cannot again record until released by breaking the circuit through *d-c*. In this case the circuit is broken by relay no. 10 which is connected so as to be actuated by treads *A*, via relay no. 8, and also by treads *B*, via relay no. 5. Hence, after the tread at *C* makes a contact, no further error may be counted by register no. 13 until the circuit has been broken as a result of the entrance of the animal into either *B* or *A*.

SUMMARY

A retracing into *A* is scored as an error on no. 12. No further error may be scored except by leaving *A*, either to *B* and return, or to *C*. An entrance into *C* is scored on no. 13, and *it* may not record again till either *A* or *B* has been entered. Thus we see that any possible combination of errors will be counted. On register no. 12, we shall have a record of the number of retracings into *A* with six additional counts which must be subtracted. On no. 13, we shall have a record of the number of entrances into culs de sac. On counter no. 11, we shall have a record of the time spent by the animal in traversing the maze.⁴

These records are all that are usually made in connection with

⁴It is possible to keep an additional record of the time spent by the animal, in the culs de sac. This is obtained by inserting the magnet of another relay in series with *d-c*, from *c* to the wire leading to it. The contacts of this relay are then connected to another counter-clock circuit so that when the relay is closed the counter is actuated by the clock. The additional apparatus would be one counter and one ordinary relay (make type).

most maze studies. The saving of time, usually spent in watching the animal run the maze and in recording the errors, is considerable, even with a small maze of this nature, amounting to about fifteen or twenty minutes per rat on the first few days. With this maze it is possible merely to put the animal into the starting box and leave him, returning only when it is desired to make another run. By using several such mazes of identical construction, it would be possible to run several rats at once, with a still greater saving of time. Since the apparatus can be adapted to so many uses, and since the economy of time as a result of its employment is so great, the writers feel that the financial outlay involved is more than equalled by saving in other ways.

In some, as yet unpublished, studies being made at this University by Mr. Hugh C. Blodgett, it was desired to count only the entrances into the culs de sac and to count only one such entrance per choice (section). Under these conditions the animal may make any number of errors from zero to six. The record desired was the actual number made. This can be accomplished automatically with our apparatus by using the arrangement shown in figure 5. If a record of the time is desired, the time counter is connected in the manner shown in figure 1, otherwise it may be left out. The contacts of the *B* treads are not connected, and the *A* contacts and *C* contacts are connected as shown in figure 5. An entrance into *C* actuates the counter, and an entrance into *A* clears it for another count, through the action of the circuit-breaking relay shown in the diagram. To prevent this occurring from a re-entrance into the *A* just passed, the following device is used; An upholsterer's tack is driven into the bottom of the door in such a way that when the door is closed it holds the tread down and prevents the key from making a contact. Now, if the rat were to walk on this tread no connection would be made. The door is set as usual, so that when the rat passes through the unit for the first time a contact is made, but no subsequent connection can be made till the door is re-set. The result of this is that the rat may score one, but no more than one, error per choice, and may, of course, make no error at all. Thus in the complete run he may score no more than six errors. This fulfills the requirements of Mr. Blodgett's method.